

Section D6  
Table of Contents



2½" x 7<sup>5</sup>/<sub>16</sub>"  
for 1<sup>5</sup>/<sub>16</sub>" Laminated Glass

Specifications - PW257 .....	S1-S5
Features & Benefits .....	1
High Velocity Hurricane Zone Applications .....	2
Standard Framing - Wet Glazed - Captured System.....	3
Standard Framing - Dry Glazed - Captured System.....	4
Standard Framing - Wet Glazed - Structural Silicone Glazed System .....	5
Standard Framing - Dry Glazed - Structural Silicone Glazed System.....	6
Entrance Framing .....	7
Thermal Charts .....	8-12

# PW257·2½" x 7<sup>5</sup>/<sub>16</sub>"

Impact-Resistant Curtain Wall

---



Page Left Intentionally Blank

## GUIDE SPECIFICATION

Manufacturer:

Coral Architectural Products  
3010 Rice Mine Road  
Tuscaloosa, AL. 35406  
Voice: (800) 772-7737  
Fax: (800) 443-6261

### SECTION 08900 ALUMINUM CURTAIN WALL

This suggested guide specification has been developed using the current edition of the Construction Specifications Institute (CSI) "Manual of Practice," including the recommendations for the CSI 3 Part Section Format and the CSI Page Format. The developmental concept and organizational arrangement used by the American Institute of Architects (AIA) MASTERSPEC Program were recognized in the preparation of this guide specification. Neither CSI nor AIA endorse specific manufacturers and products. The preparation of the guide specification assumes the use of standard contract documents and forms, including the "Conditions of the Contract," published by the AIA.

### PART 1 – GENERAL

#### 1.01 Summary

- A. Section Includes: Coral Architectural Products™, including perimeter trims, stools, accessories, shims and anchors, and perimeter sealing of curtain wall framing.
  - 1. Types of Coral Architectural Products include:
    - a. Series PW257 Panelized Curtain Wall System: 2-1/2" x 7-5/16" Impact-Resistant Curtain Wall System outside glazed captured pressure wall system for 1-5/16" monolithic laminated safety glass. (Select)
    - b. Series PW257 Panelized Curtain Wall System: 2-1/2" x 7-5/16" Impact-Resistant Curtain Wall System outside glazed (SSG) structural silicone glazed pressure wall system for 1-5/16" monolithic laminated safety glass. (Select)
- B. Related Sections:
  - 1. Division 7 Section "Vapor Barriers" between glazed wall systems and adjacent construction
  - 2. Division 7 Section "Fire Stopping"
  - 3. Division 7 Section "Joint Sealants" for joint sealants installed as part of aluminum entrance, storefront system, and curtain wall systems.
  - 4. Division 8 Section "Glazed Aluminum Curtain Walls"
  - 5. Division 8 Section "Aluminum Windows Walls"
  - 6. Division 8 Section "Aluminum Entrances and Storefronts"
  - 7. Division 8 Section "Aluminum Mall Sliding Doors"
  - 8. Division 8 Section "Finish Hardware"
  - 9. Division 8 Section "Glass and Glazing"

EDITOR NOTE: REFER TO INDEX FOR ANY AND ALL APPLICABLE STANDARDS.

#### 1.02 References (Industry Standards)

#### 1.03 System Description

- A. Curtain Wall System Performance Requirements:
  - 1. Wind loads: Provide framing system; include anchorage, capable of withstanding wind load design pressures of (\_\_\_\_) P.S.F. inward (\_\_\_\_) P.S.F. outward. The design pressures are based on the (\_\_\_\_) Building Code; (\_\_\_\_) Edition.
  - 2. Air Infiltration: The test specimen shall be tested in accordance with the Florida Building Code TAS 202 and ASTM E 283. Air infiltration rate shall not exceed 0.06 cfm/ft<sup>2</sup> at a (static) air pressure differential of 6.24 PSF.
  - 3. Water Resistance, (static): The test specimen shall be tested in accordance with the Florida Building Code TAS 202 and ASTM E 331 for (outside) or (inside). There shall be no leakage at a minimum static air pressure differential of 20 PSF as defined in AAMA 501.

### GUIDE SPECIFICATION

4. Uniform Load: A static air design load of +80/-80 P.S.F. with steel reinforcing (60" Spacing x 150" Span) or +65/-65 P.S.F. without steel reinforcing (48" Spacing x 108" Span) shall be applied in the positive and negative direction in accordance with DCBCCO Protocol PA 202 and ASTM E 330. There shall be no deflection in excess of L/180 of the span of any framing member. At a structural test load equal to 1.5 times the specified design load, no glass breakage or permanent set in the framing members in excess of 0.4% of their clear spans shall occur.
5. Impact Resistance: Large Missile, tested in accordance with Florida Building Code Protocols TAS 201, TAS 203, and ASTM E 1886/1996.

#### 1.04 Submittals

- A. General: Prepare, review, approve and submit specified submittals in accordance with "Conditions of the Contract" and Division 1 Submittals Sections. Product data, shop drawings, samples and similar submittals are defined in "Conditions of the Contract."
- B. Quality Assurance/Control Submittals:
  1. Test Reports: Submit certified test reports showing compliance with specified performance characteristics.

#### 1.05 Warranty

- A. Project Warranty: Refer to "Conditions of the Contract" for project warranty provisions.
- B. Manufacturer's Product Warranty: Submit, for Owner's acceptance, manufacturer's warranty for curtain wall system as follows:
  1. Warranty Period: Two (2) years from Date of Substantial Completion of the project. The Limited Warranty shall begin in no event later than six months from date of initial shipment by **Coral Architectural Products** without regard to the date selected as substantial completion.

#### 1.06 Quality Assurance

- A. Qualifications:
  1. Installer Qualifications: Installer experienced (as determined by contractor) to perform work of this section who has specialized in the installation of work similar to that required for this project and who is acceptable to product manufacturer.
  2. Manufacturer Qualifications: Manufacturer capable of providing field service representation during construction, approving acceptable installer and approving application method.
- B. Pre-Installation Meetings: Conduct pre-installation meeting to verify project requirements, substrate conditions, manufacturer's installation instructions and manufacturer's warranty requirements.

#### 1.07 Delivery, Storage, and Handling

- A. Ordering: Comply with manufacturer's ordering instructions and scheduling requirements to avoid construction delays.
- B. Packing, Shipping, Handling and Unloading: Deliver materials in manufacturer's original, unopened, undamaged containers with identification labels intact.
- C. Storage and Protection: Store materials protected from exposure to harmful weather conditions. Handle curtain wall material and components to avoid damage. Protect curtain wall material against damage from elements, construction activities and other hazards before, during and after curtain wall installation.

### PART 2 – PRODUCTS

EDITOR NOTE: RETAIN BELOW ARTICLE FOR PROPRIETARY METHOD SPECIFICATION; ADD PRODUCT ATTRIBUTES, PERFORMANCE CHARACTERISTICS, MATERIAL STANDARDS, AND DESCRIPTIONS AS APPLICABLE. DO NOT USE THE PHRASE "OR EQUAL" / "OR APPROVED EQUAL," OR SIMILAR PHRASES. USE OF SUCH PHRASES CAN CAUSE AMBIGUITY IN THE SPECIFICATIONS DUE TO THE DIFFERENT INTERPRETATIONS AMONG THE DIVERGENT PARTIES OF THE CONSTRUCTION PROCESS AND READERS OF THESE SPECIFICATIONS. SUCH PHRASES REQUIRE EXTENSIVE AND COMPLETE REQUIREMENTS (PROCEDURAL, LEGAL, REGULATORY AND RESPONSIBILITY) FOR DETERMINING "OR EQUAL."

## GUIDE SPECIFICATION

### 2.01 Manufacturers (Acceptable Manufacturers/Products)

- A. Acceptable Manufacturers:
1. Address: Coral Architectural Products, a division of Coral Industries  
3010 Rice Mine Road  
Tuscaloosa, AL. 35406  
Contact Numbers:
    - a. Telephone: (800) 772-7737
    - b. Fax: (800) 443-6261
    - c. Email: info@coralap.com
    - d. Web address: www.coralap.com
  2. Proprietary Product(s)/System(s): Coral Architectural Products
    - a. Series: PW257 outside glazed impact-resistant pressure wall curtain wall system

EDITOR NOTE: RETAIN BELOW FOR ALTERNATE MANUFACTURERS/PRODUCTS AS SPECIFIED IN THE CONTRACT DOCUMENTS. COORDINATE BELOW WITH BID DOCUMENTS (IF ANY) AND DIVISION 1 ALTERNATES SECTION. CONSULT WITH CORAL ARCHITECTURAL PRODUCTS FOR RECOMMENDATIONS ON ALTERNATE MANUFACTURERS AND PRODUCTS MEETING THE DESIGN CRITERIA AND PROJECT REQUIREMENTS. CORAL ARCHITECTURAL PRODUCTS RECOMMENDS OTHER MANUFACTURERS REQUESTING APPROVAL TO BID THEIR PRODUCT AS AN EQUAL, MUST SUBMIT THEIR REQUEST IN WRITING, TEN (10) DAYS PRIOR TO CLOSE OF BIDDING.

- b. Finish/Color: (See 2.06 Finishes)
  - c. Framing Member Profile: 2-1/2 x 7-5/16" nominal dimension; pressure bar; screw-spline fabrication
- B. Alternate (Manufacturers/Products): In lieu of providing below specified base bid/contract manufacturer, provide below specified alternate manufacturers. Refer to Division 1 Alternates Section.
1. Base Bid/Contract Manufacturer/Product: Coral Architectural Products
    - a. Product: Architectural Aluminum
    - b. Series PW257 Panelized System: 2-1/2" x 7-5/16" nominal dimension; pressure bar; screw-spline fabrication
- C. Substitutions:
1. General: Refer to Division 1 Substitutions for procedures and submission requirements.
    - a. Pre-Contract (Bidding Period) Substitutions: Submit written requests ten (10) days prior to bid date.
    - b. Post-Contract (Construction Period) Substitutions: Submit written request in order to avoid curtain wall installation and construction delays.
  2. Substitution Documentation
    - a. Product Literature and Drawings: Submit product literature and drawings modified to suit specific project requirements and job conditions.
    - b. Certificates: Submit certificate(s) certifying substitute manufacturer attesting to adherence to specification requirements for curtain wall system performance criteria.
    - c. Test Reports: Submit test reports verifying compliance with each test requirement for curtain wall required by the project.
    - d. Product Sample and Finish: Submit product sample, representative of curtain wall for the project, with specified finish and color.
  3. Substitution Acceptance: Acceptance will be in written form, either as an addendum or modification, and documented by a formal change order signed by the Owner and Contractor.

### 2.02 Materials

- A. Aluminum (Curtain wall and Components):
1. Material Standard: Extruded Aluminum, ASTM B 221, 6063-T6 alloy and temper.
  2. Member Wall Thickness: Each framing member shall have a wall thickness sufficient to meet the specified structural requirements.
  3. Tolerances: Reference to tolerances for wall thickness and other cross-sectional dimensions of storefront framing members are nominal and in compliance with Architectural Aluminum Standards and Data.

## GUIDE SPECIFICATION

### 2.03 Accessories

- A. Fasteners: Where exposed, shall be Stainless Steel.
- B. Gaskets: Glazing gaskets shall comply with ASTM C 864 and be extruded of silicone compatible EPDM material that provides for silicone adhesion.
- C. Perimeter Anchors: Aluminum; When steel anchors are used, provide insulation between steel material and aluminum material to prevent galvanic action.
- D. Thermal Barrier: Thermal separator shall be extruded of a silicone compatible elastomer that provides for silicone adhesion.

### 2.04 Related Materials

- A. Sealants: Refer to Joint Treatment (Sealants) Section.
- B. Glass: Refer to Glass and Glazing Section.

### 2.05 Fabrication

- A. General:
  - 1. Fabricate components per manufacturer's installation instructions and with minimum clearances and shim spacing around perimeter of assembly, yet enabling installation and dynamic movement of perimeter seal.
  - 2. Accurately fit and secure joints and corners. Make joints flush, hairline and weatherproof.
  - 3. Arrange fasteners and attachments to conceal from view.

### 2.06 Finishes

EDITOR NOTE: SELECT BELOW FINISH AND COLOR FROM CORAL ARCHITECTURAL PRODUCT'S STANDARD COLORS. CORAL'S POWDER COAT FINISHES ARE HIGH-PERFORMANCE DURABLE FINISHES OFFERING IMPROVED GLOSS RETENTION AND ENHANCED RESISTANCE TO CHALKING AND FADING. CUSTOM COLORS ARE AVAILABLE UPON REQUEST FROM CORAL ARCHITECTURAL PRODUCTS IN A TWO COMPONENT POLYESTER POWDER COAT FINISH CONFORMING TO AAMA 2604 AND (70%) THERMOSETTING FLUOROPOLYMER POWDER COAT FINISH CONFORMING TO AAMA 2605. CONSULT WITH YOUR CORAL SALES OR ARCHITECTURAL REPRESENTATIVE FOR OTHER SURFACE TREATMENTS AND FINISHES.

- A. Shop Finishing
  - 1. Color Anodizing Conforming to AA-M12C22A34, AAMA 611, Architectural Class I. Color Anodic Coating (Color: #20 Dark Bronze) (Standard) or AA-M12C22A44, AAMA 611, Architectural Class I. Color Anodic Coating (Color: #30 Black) (Select).
  - 2. Clear Anodizing Conforming to AA-M12C22A31, AAMA 611, Architectural Class I. Clear Anodic Coating (Clear: #10) (Standard).
  - 3. Two Component Polyester Powder Coating Conforming to AAMA 2604 (Color: \_\_\_\_\_).
  - 4. (70%) Fluoropolymer Thermosetting Powder Coating Conforming to AAMA 2605 (Color: \_\_\_\_\_).
  - 5. Other: Manufacturer \_\_\_\_\_ Type \_\_\_\_\_ Color: \_\_\_\_\_).

### 2.07 Source Quality Control

- A. Source Quality: Provide aluminum curtain wall specified herein from a single source.
  - 1. Building Enclosure System: When aluminum curtain walls are part of a building enclosure system, including entrances, entrance hardware, windows, curtain wall framing and related products, provide building enclosure system products from a single source manufacturer.

## PART 3 – EXECUTION

### 3.01 Examination

- A. Site Verification of Conditions: Verify substrate conditions (which have been previously installed under other sections) are acceptable for product installation in accordance with manufacturer's instructions. Verify openings are sized to receive specified system and sill plate is level in accordance with manufacturer's acceptable tolerances.

## GUIDE SPECIFICATION

EDITOR NOTE: COORDINATE BELOW ARTICLE WITH MANUFACTURER'S RECOMMENDED INSTALLATION DETAILS AND INSTALLATION INSTRUCTIONS.

1. Field Measurements: Verify actual measurements/openings by field measurements before fabrication; show recorded measurements on shop drawings. Coordinate field measurements, fabrication schedule with construction progress to avoid construction delays.

### 3.02 Installation

- A. General: Install curtain wall systems plumb, level, and true to line, without warp or rack of frames with manufacturer's prescribed tolerances and installation instructions. Provide support and anchor in place.
  1. Dissimilar Materials: Provide separation of aluminum materials from sources of corrosion or electrolytic action contact points.
  2. Glazing: Glass shall be outside glazed and held in place with extruded aluminum pressure bars anchored to the mullion using stainless steel fasteners spaced no greater than 9" on center.
  3. Water Drainage: Each light of glass shall be compartmentalized by using end dams at horizontal/vertical joint intersections and silicone sealant to divert water to the horizontal weeps. Weep holes shall be located in the horizontal pressure bars and covers to divert water to the exterior of the building.
- B. Related Products Installation Requirements:
  1. Sealants (Perimeter): Refer to Division 7 Joint Treatment (Sealants) Section.
  2. Glass: Refer to Division 8 Glass and Glazing Section.
    - a. Reference: ANSI Z97.1, CPSC 16 CFR 1201 and GANA Glazing Manual.

### 3.03 Field Quality Control

- A. Field Tests: Architect shall select curtain wall units to be tested as soon as a representative portion of the project has been installed, glazed, perimeter caulked and cured. Conduct tests for air infiltration and water penetration with manufacturer's representative present. Tests not meeting specified performance requirements and units having deficiencies must be corrected as part of the contract amount.
  1. Testing: Testing shall be performed per AAMA 503 by a qualified independent testing agency. Refer to Division Testing Section for payment of testing and testing requirements.
    - a. Air Infiltration Tests: Conduct tests in accordance with ASTM E 783. Allowable air infiltration shall not exceed 1.5 times the amount indicated in the performance requirements or 0.09 cfm/ft<sup>2</sup>, whichever is greater.
    - b. Water Infiltration Tests: Conduct tests in accordance with ASTM E 1105. No uncontrolled water leakage is permitted when tested at a static test pressure of two-thirds the specified water penetration pressure but not less than 8 PSF.
- B. Manufacturer's Field Services: Upon Owner's request, provide manufacturer's field service consisting of product use recommendations and periodic site visit for inspection of product installation in accordance with manufacturer's instructions.

### 3.04 Protection and Cleaning

- A. Protection: Protect installed product's finish surfaces from damage during construction. Protect aluminum curtain wall system from damage from grinding and polishing compounds, plaster, lime, acid, cement or other harmful contaminants.
- B. Cleaning: Repair or replace damaged installed products. Installed products are to be cleaned in accordance with manufacturer's instructions prior to owner's acceptance. Remove construction debris from project site and legally dispose of debris.

## DISCLAIMER STATEMENT

This guide specification is intended for use by a qualified construction specifier. The guide specification is not intended to be verbatim as a project specification without appropriate modifications for the specific use intended. The guide specification must be used and coordinated with the procedures of each design firm and the particular requirements of a specific construction project.

**END OF SECTION 08410**

# PW257·2½" x 7<sup>5</sup>/<sub>16</sub>"

## Impact-Resistant Curtain Wall

### FEATURES AND BENEFITS

#### System Description

Panelized construction using proven screw spline joinery reduces fabrication and installation time. Interior horizontal snap-on trim covers increase quality by allowing inspection and repair of critical horizontal/vertical seals and perimeter anchor attachment to substrate prior to or after glazing. Framing panels can be shop fabricated, assembled, transported to job site and then coupled together creating a complete panelized curtain wall installation.

#### Glazing Features:

- Same EPDM dense gasket used on interior and exterior at glass

#### Screw spline joinery allows:

- Coral Punch die shop fabrication
- Die set punches spline and pressure bar weep holes
- Panelized frame assembly for easy transporting and installation
- Eliminates "T" anchors

#### Pressure Bars:

- Factory installed EPDM thermal isolator with attachment holes pre-punched 9" O.C.

#### Interior Snap-on Covers:

- Inspection and/or repair of critical joint seal areas prior to and after glazing
- Perimeter anchor attachment and inspection

#### Injection molded plastic end dams and bridges at horizontals provide:

- Tight seals at intersection of vertical/horizontal joints for zone glazing

#### Aluminum top and bottom vertical mullion caps:

- Provides continuous perimeter seal

#### Injection molded plastic temporary glazing retainer:

- Reduces labor
- Distributes uniform pressure on glass reducing risk of breaking glass
- Reusable for next project

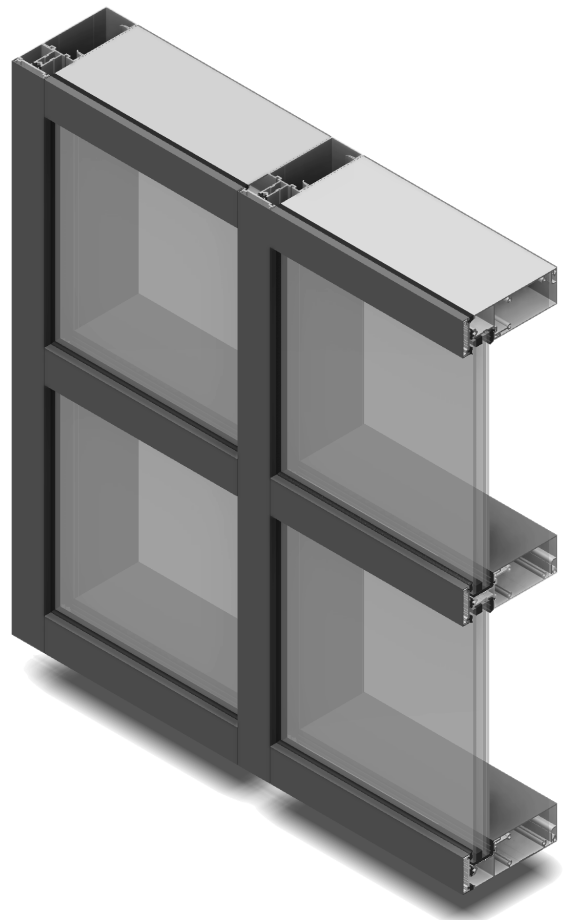

#### Performance Test Standards

- ASTM E 283 / \*TAS 202 – Air Infiltration Test
- ASTM E 331 / \*TAS 202 – Water Infiltration Test
- ASTM E 330 / \*TAS 202 – Uniform Load Deflection and Structural Test
- ASTM E 1886/1996 / \*TAS 201-203 – Missile Impact and Cycling Test
- Florida Product Approval Number – FL14495 (Impact-Resistant use in HVHZ)

*\*Indicates test standards in compliance with the current Florida Building Code.*



## High Velocity Hurricane Zone Applications

### Series PW257 Hurricane Impact-Resistant Curtain Wall System

#### Qualified System Configuration Chart

Design Pressure P.S.F.	Intermediate Vertical Mullion Without Steel	Intermediate Vertical Mullion With Steel SR150 with 1/2"x4" Bar Welded	Intermediate Vertical Mullion With Steel SR150 with 3/4"x4" Bar Welded	Wall Jamb Mullion Must Be Anchored at Horizontals	Maximum Un-Spliced Mullion	Maximum Mullion Anchor Point	Maximum Mullion Spacing Center to Center * see notes	Maximum Glass Size D.L.O.	Square Feet	Qualified Glass Types
<b>PW257 Impact Resistant Curtain Wall - Captured</b>										
+65/-65	PW650/202			PW650/202	108"		48"	45 ½" x 84"	26.5	IB, ID, IE
+80/-80		PW650/202		PW650/202	150"	150"	60"	57 ½" x 96"	38.3	ID
+80/-80			PW650/202	PW650/202	150"	150"	76 1/2" *(1)	74" x 47 ¼"	28.2	ID
+80/-80	*(3)	Corner PW208/209 and SR504			150"	150"	60"	57 ½" x 96"	38.3	ID
<b>PW257 Impact Resistant Curtain Wall - Butt Glazed</b>										
+80/-80		PW151/202		PW650/202		150"	48"	45 ½" x 96"	30.5	IB, ID, IE
+80/-80	*(2)	Corner Captured Only PW208/209 and SR504			150"	150"	48"	45 ½" x 96"	30.5	ID
<b>PW257 Impact Resistant Curtain Wall - Dry Glazed</b>										
+80/-80		PW650/202		PW650/202	150"		60"	57 ½" x 96"	38.3	ID

#### Hurricane Impact-Resistant Products Disclaimer Note

Coral's hurricane impact-resistant products meet a variety of test standards for applications in coastal construction regions satisfying the demands for wind-borne debris hazards and high-velocity winds associated with hurricanes. All of Coral's hurricane impact-resistant products are independent laboratory tested based on a variety of test standards for air infiltration, water resistance, structural loads, missile impact and air-pressure cycling based on ASTM and/or Florida Building Code. The informational chart above is intended to provide recommended limits in frame heights, glass sizes and design pressures based on product testing. When exceeding conditions listed above, it is recommended to consult with a licensed structural engineer or contact Coral Architectural Products.

#### Qualified Glass Types

Glass Type	Glass Composition			Interlayer Manufacturer	Glass Identification
	Exterior Lite	Air Space/ Spacer Type	Interior Lite		
1 <sup>5</sup> / <sub>16</sub> " Insulated Glass	¼" Heat Strengthened Glass	½" Air Space with Aluminum Box Spacer	¼" Heat Strengthened Glass .090 Saflex PVB Interlayer ¼" Heat Strengthened Glass	Solutia	IB
1 <sup>5</sup> / <sub>16</sub> " Insulated Glass	¼" Heat Strengthened Glass	½" Air Space with Aluminum Box Spacer	¼" Heat Strengthened Glass .090 Butacite PVB Interlayer ¼" Heat Strengthened Glass	DuPont™	IE
1 <sup>5</sup> / <sub>16</sub> " Insulated Glass	¼" Heat Strengthened Glass	½" Air Space with Aluminum Box Spacer	¼" Heat Strengthened Glass .090 Sentry GlasInterlayer ¼" Heat Strengthened Glass (Dry-Glazed Application)	DuPont™	ID

#### Comparative Analysis of Glass Based on ASTM E-1300

##### \* Notes

1. Based on opening for door and frame. Horizontals must be used at 48" intervals.
2. Captured corner can be used with butt glazed system. Mullion spacing cannot exceed 48" on center.
3. Corner assembly consists of PW 208/209/154/PW210 and SR 504 Steel.

# PW257·2½" x 7<sup>5</sup>/<sub>16</sub>"

## Impact-Resistant Curtain Wall

Standard Framing - Captured System  
Scale: 3" = 1'-0"

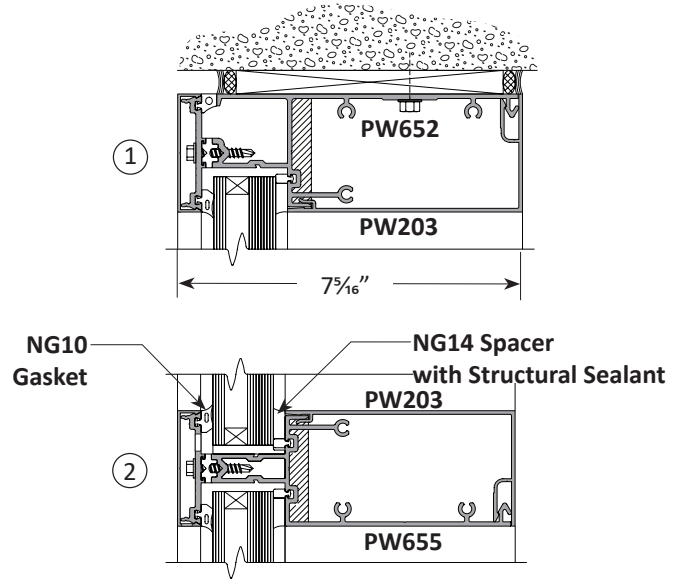
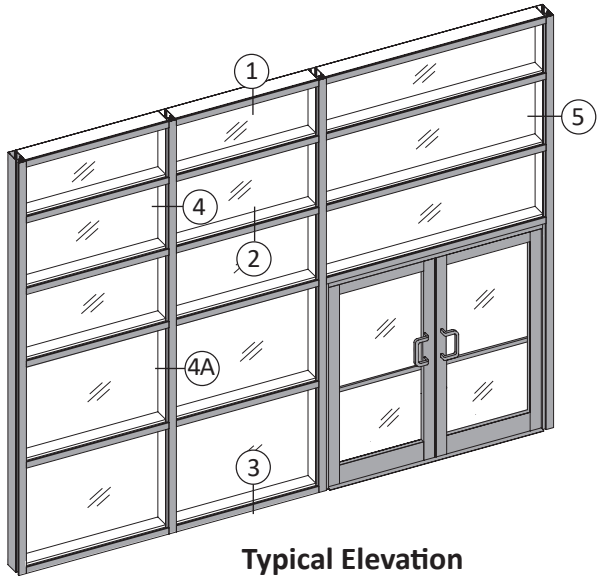

### Wet Glazed Application

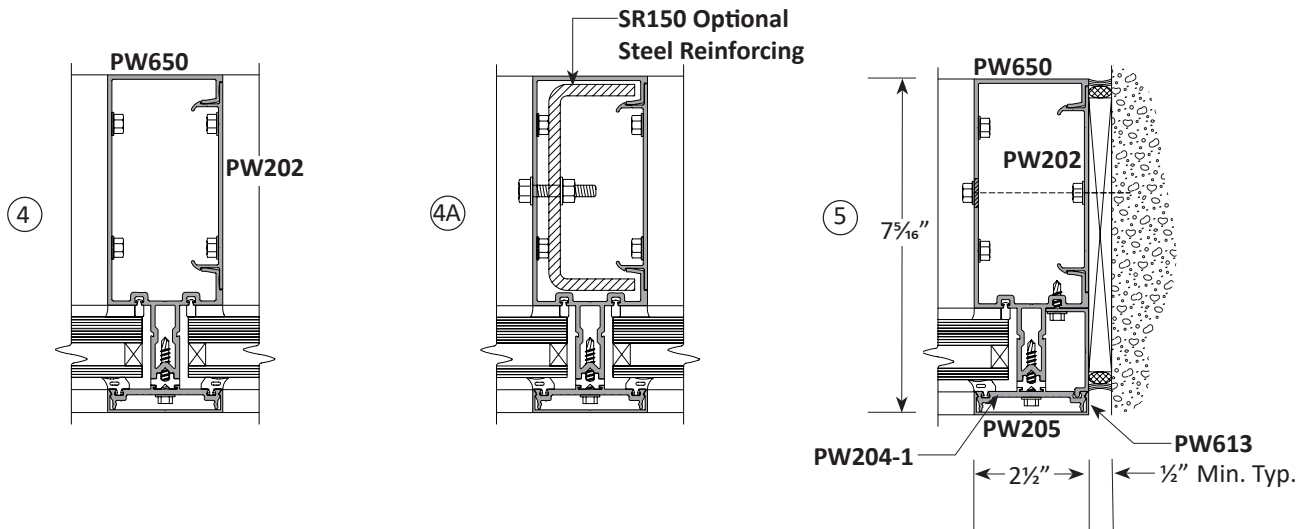
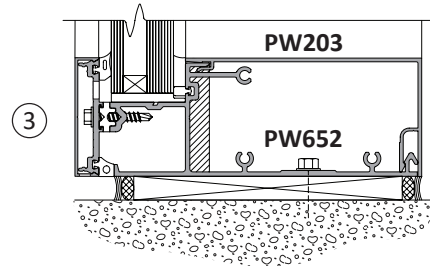

# PW257·2½" x 7<sup>5</sup>/<sub>16</sub>" Impact-Resistant Curtain Wall

Standard Framing - Captured System  
Scale: 3" = 1'-0"

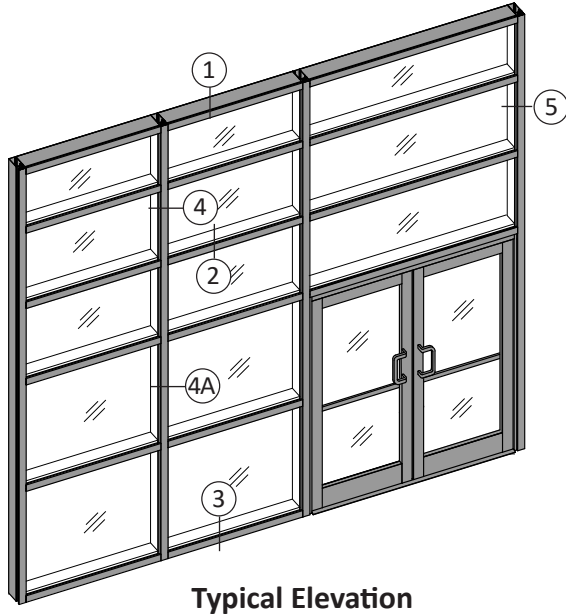

**Dry Glazed Application**

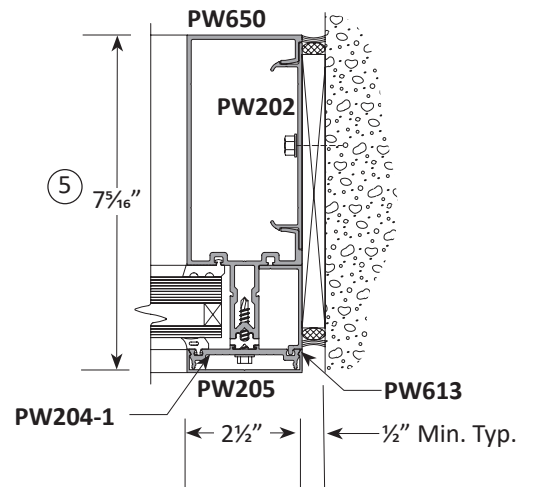
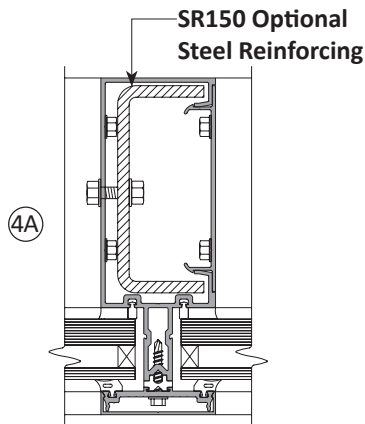
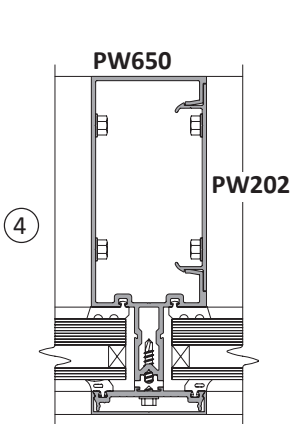
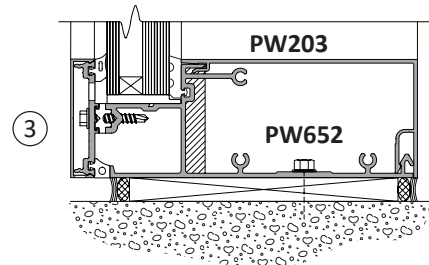
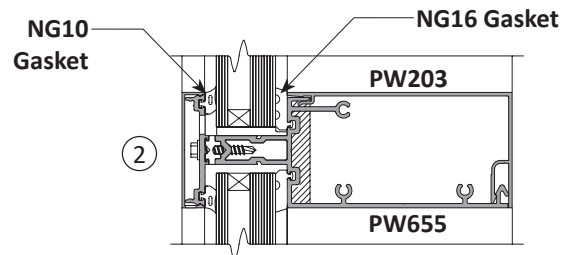
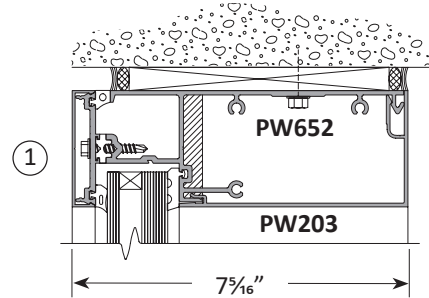

# PW257·2½" x 7<sup>5</sup>/<sub>16</sub>"

## Impact-Resistant Curtain Wall

Standard Framing - Structural Silicone Glazed (SSG) System  
Scale: 3" = 1'-0"

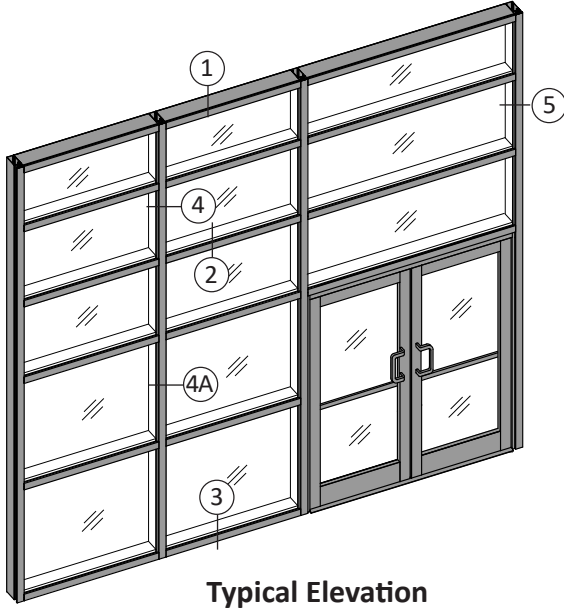

**Wet Glazed Application**

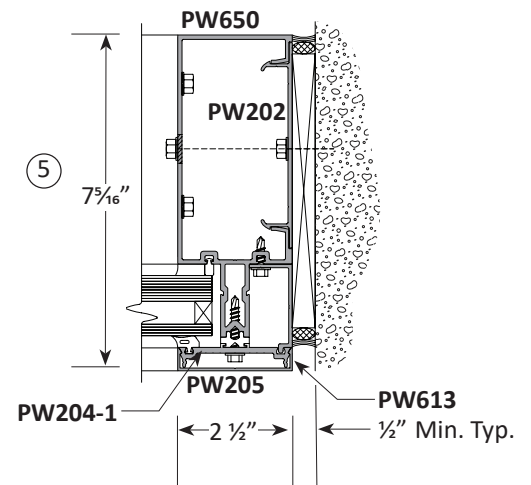
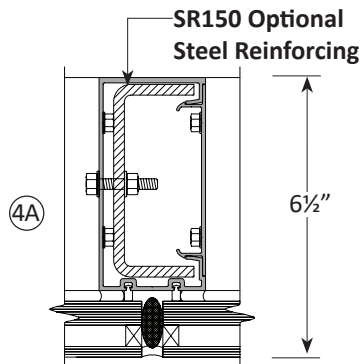
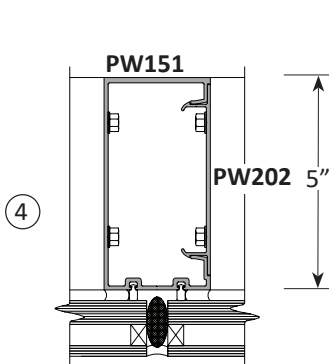
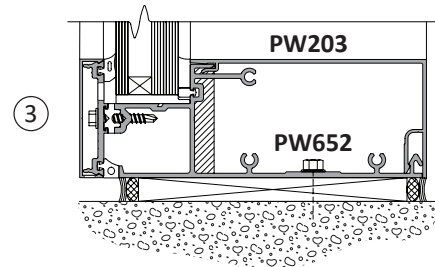
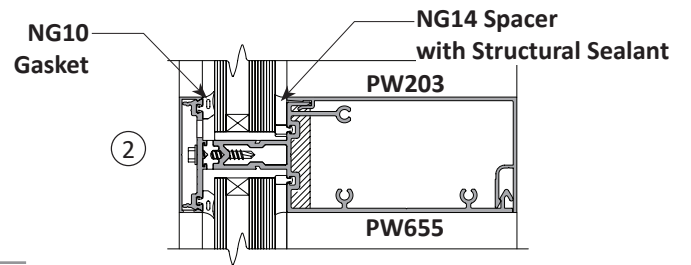
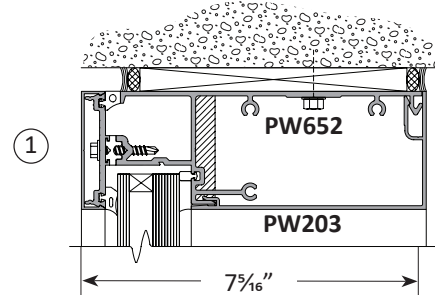

Standard Framing - Structural Silicone Glazed (SSG) System  
 Scale: 3" = 1'-0"

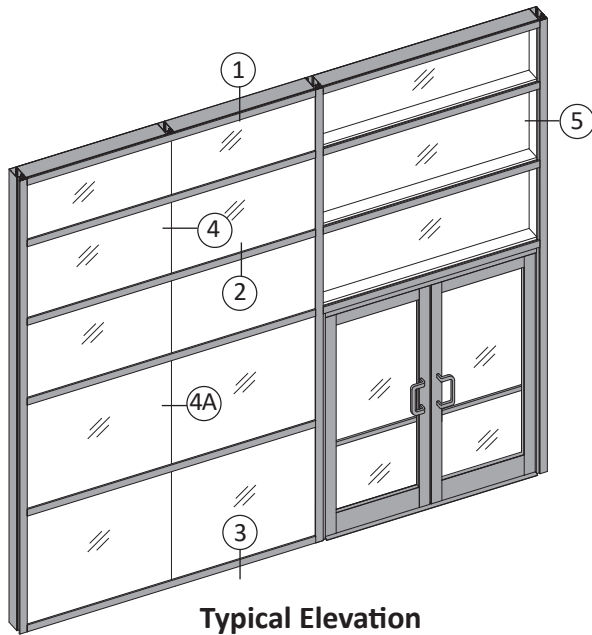

**Dry Glazed Application**

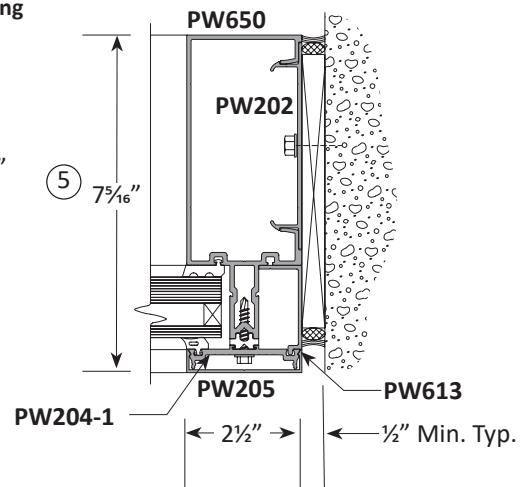
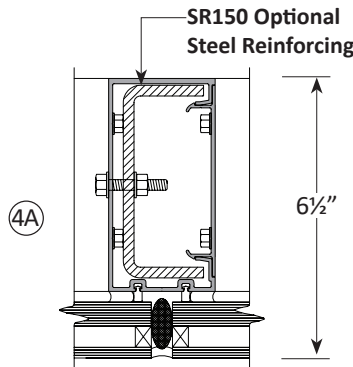
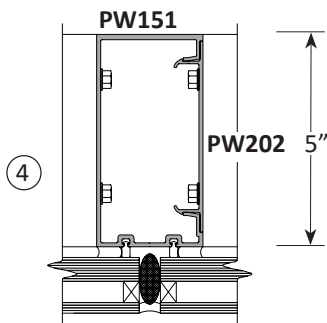
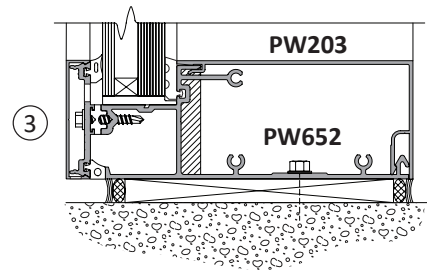
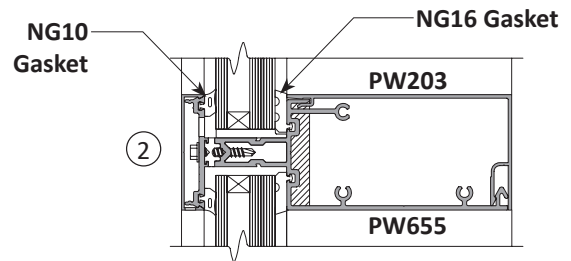
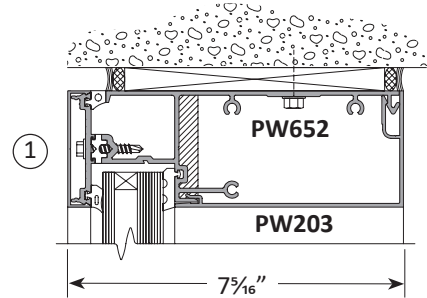

# PW257·2½" x 7⅝"

## Impact-Resistant Curtain Wall

Entrance Framing  
Scale: 3" = 1'- 0"

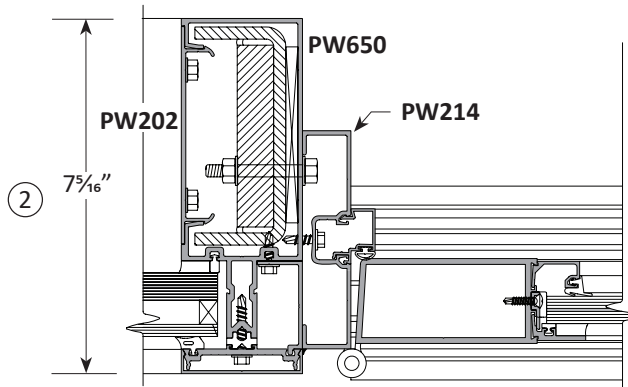
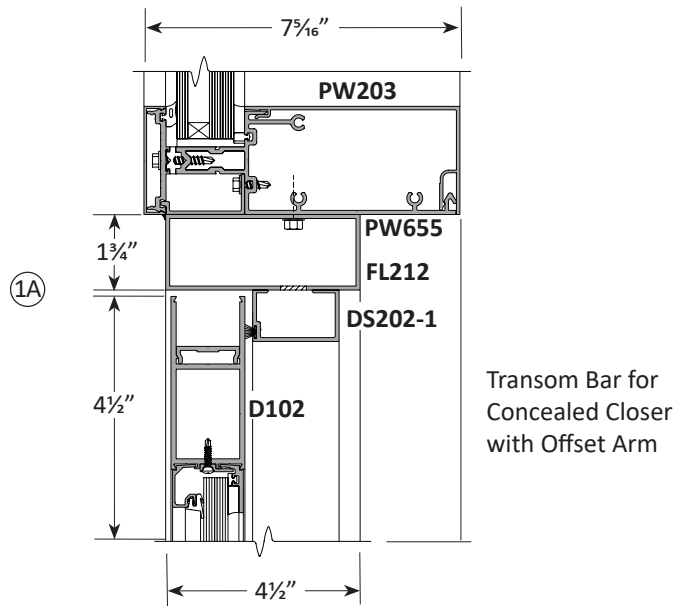
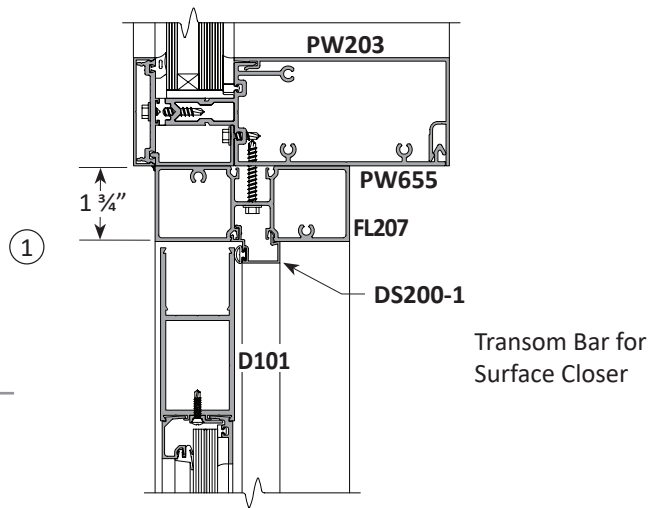
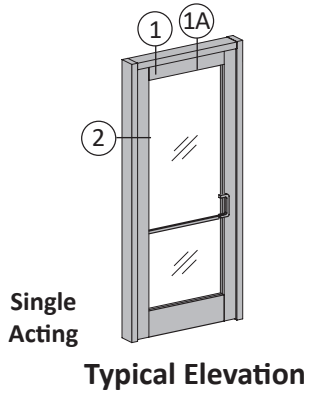

System Thermal Charts listed in the following pages are based on AAMA 507, a standard practice for determining the thermal performance of fenestration systems. AAMA 507, utilizes the same simulation standard as defined by the National Fenestration Rating Council (NFRC) providing an accurate method to evaluate how various insulating glass will perform in a storefront, entrance, curtain wall and window system.

Notes: System U-Factors, SHGC and VT charts

1. Glass properties are based on center of glass values.
2. Linear interpolation is permitted for glass values that are not included in the charts.
3. Center of glass values can be obtained from the glass supplier.
4. System U-Factors are determined in accordance with NFRC 100 and based on the standard NFRC specimen size equal to a height of 2000mm x a width of 2000mm (78¾" x 78¾").
5. SHGC and VT values are determined in accordance with NFRC 200 and based on the standard NFRC specimen size equal to a height of 2000mm x a width of 2000mm (78¾" x 78¾").

**Project Specific U-factor  
Example Calculation  
(Based on single bay of Curtain Wall/Window Wall)**

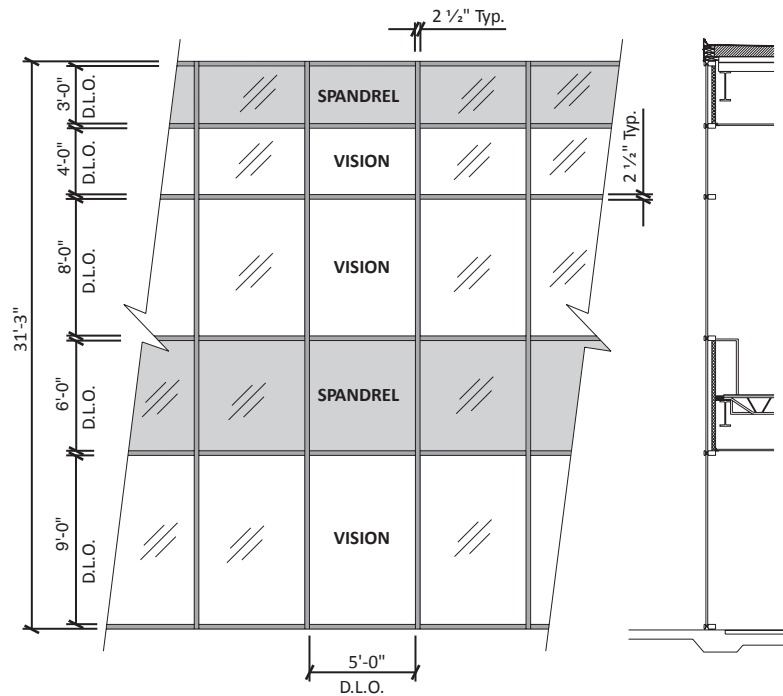

**Vision Area**

Example Glass U-Factor	= 0.48 Btu/(ft <sup>2</sup> · h · °F)
Vision Area	= 5(9 + 8 + 4) = 105.0 ft <sup>2</sup>
Total Area (Vision)	= 5' 2 ½" (9' 3 ¾" + 8' 2 ½" + 4' 2 ½") = 113.2 ft <sup>2</sup>
Percentage of Vision Glass	= (Vision Area ÷ Total Area)100
	= (105.0 ÷ 113.2) 100 = 93%

**Spandrel Area**

Example Spandrel R-Value	= 15 (ft <sup>2</sup> · h · °F)/Btu
Spandrel Area	= 5(6 + 3) = 45.0 ft <sup>2</sup>
Total Area (Spandrel)	= 5' 2 ½" (6 + 3) = 45.0 ft <sup>2</sup>
Percentage of Spandrel	= (Spandrel Area ÷ Total Area)100
	= (49.0 ÷ 49.6) 100 = 91%

# PW257·2½" x 7<sup>5</sup>/<sub>16</sub>"

## Impact-Resistant Curtain Wall

### Thermal Charts

#### System U-Factor vs. Percentage of Vision Area

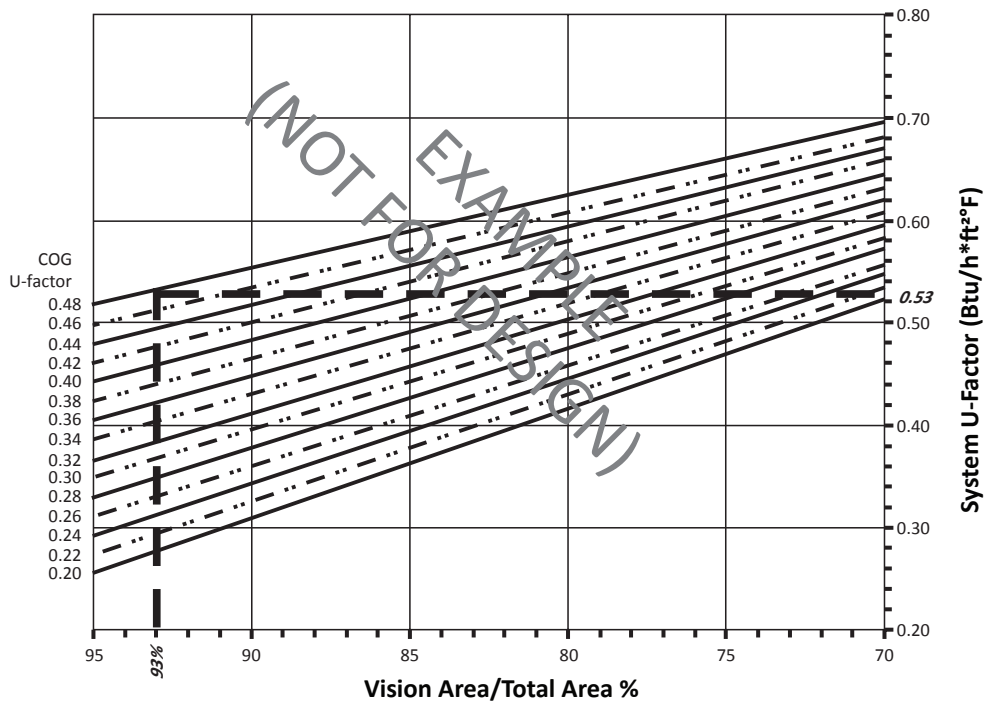

Based on a single curtain wall bay of 93% vision glass and center of glass U-factor of 0.48, System U-factor is equal to 0.53 Btu/(h·ft<sup>2</sup>·°F)

#### System U-Factor vs. Percentage of Spandrel Area

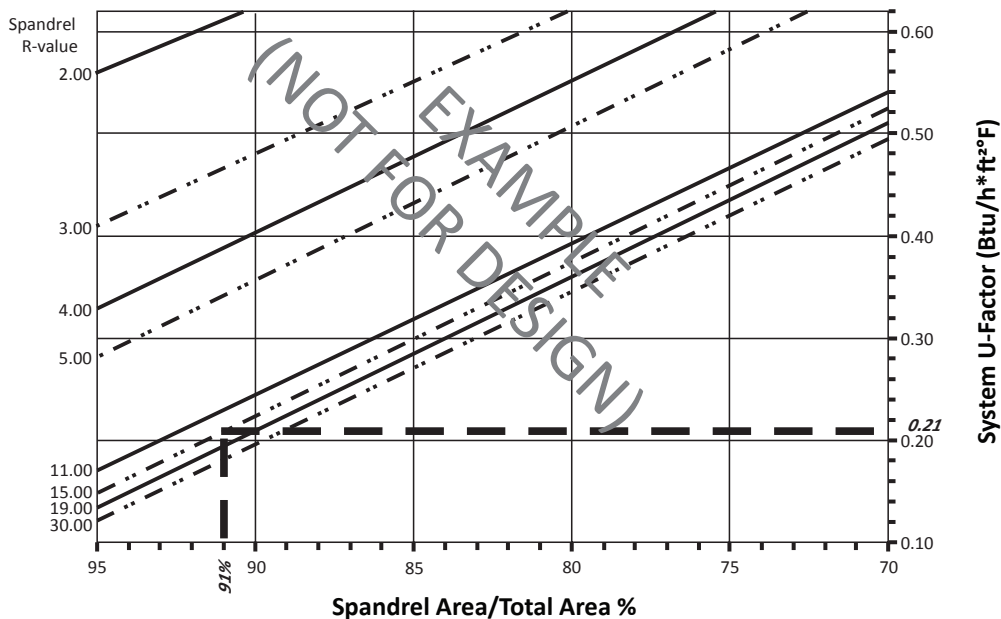

Based on a single curtain wall bay of 91% spandrel and center of spandrel R-value of 15, system U-factor is equal to 0.21 Btu/(h·ft<sup>2</sup>·°F)



**System U-Factor vs. Percentage of Vision Area**

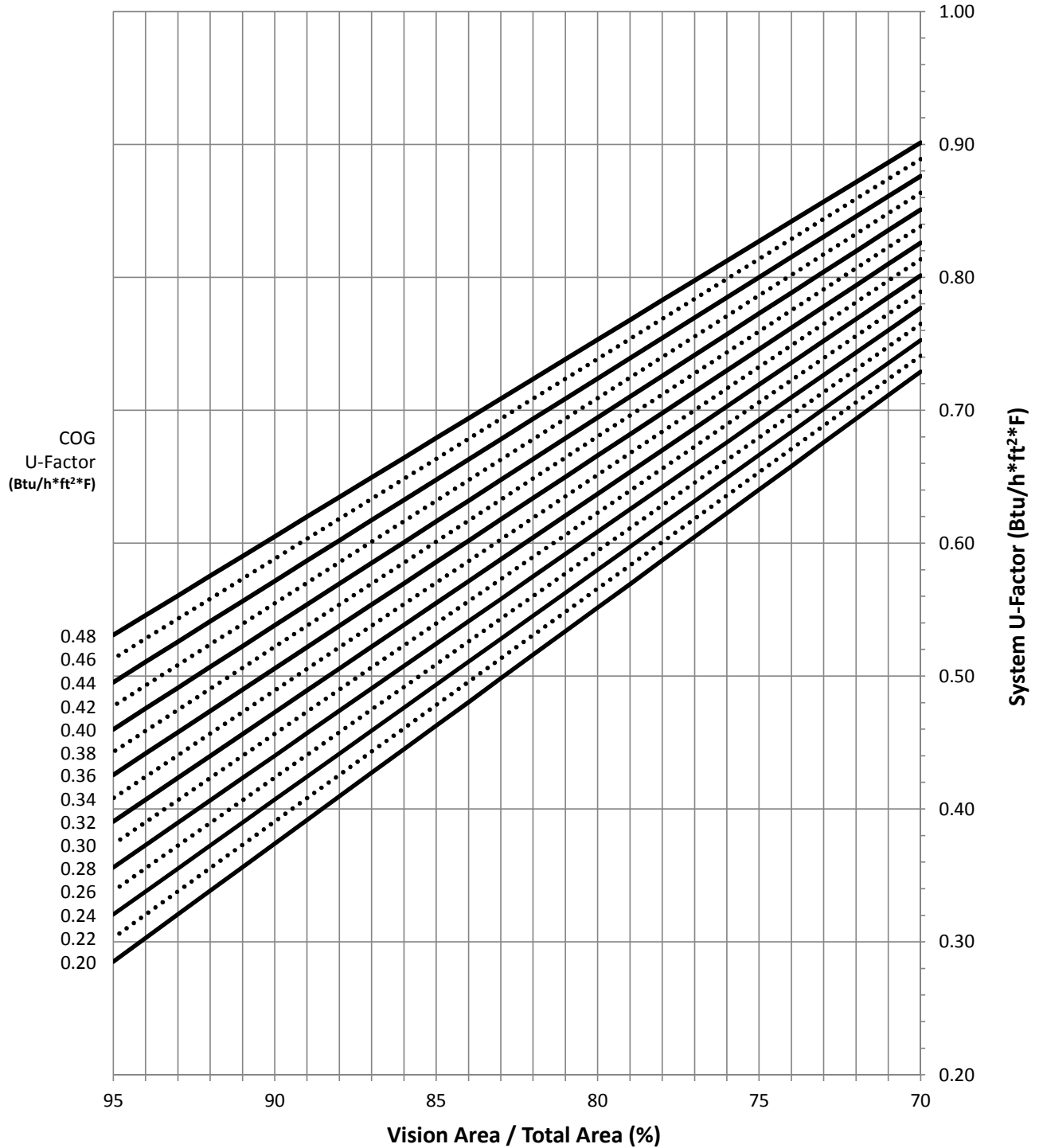

# PW257·2½" x 7<sup>5</sup>/<sub>16</sub>"

## Impact-Resistant Curtain Wall



### Thermal Charts

System SHGC vs. Percentage of Vision Area

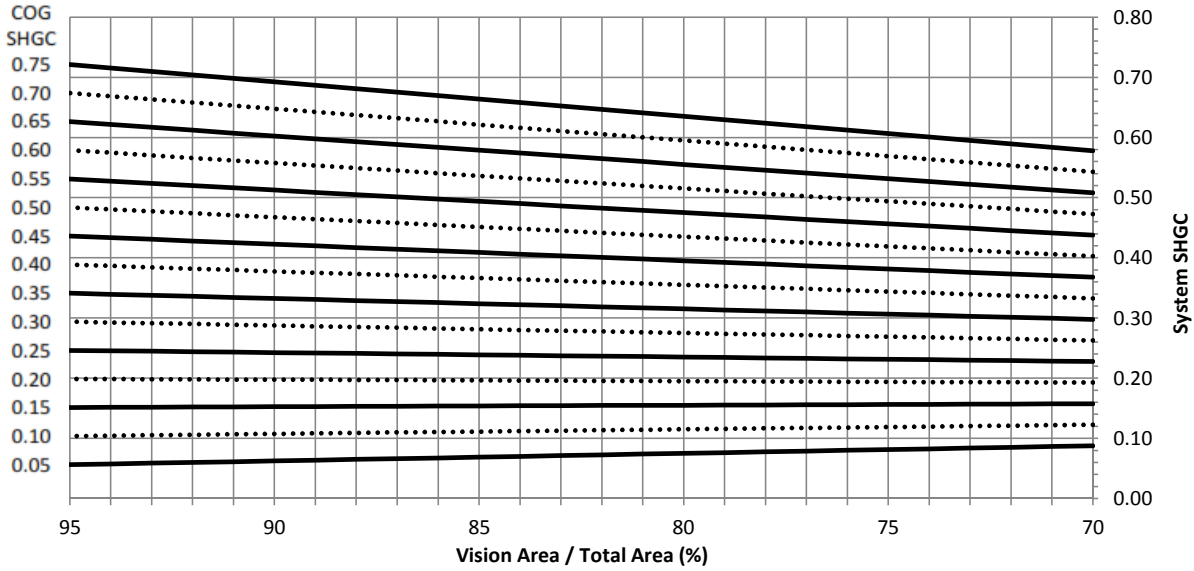

System VT vs. Percentage of Vision Area

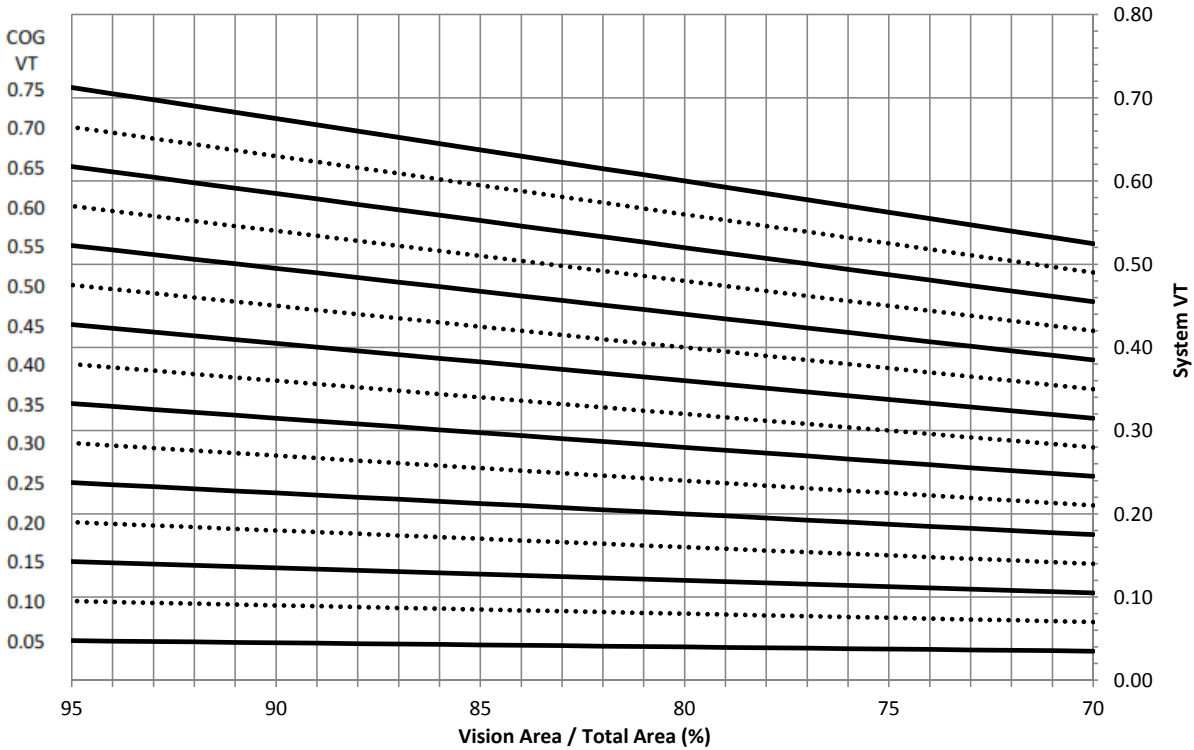

**Size-Specific U-Factor (Btu/h-ft<sup>2</sup>-F) Matrix: NFRC Standard Size (78.740" x 78.740")<sup>4</sup>**

Glazing Option	Center-of-Glass U-Factor	Overall U-Factor
1	0.48	0.62
2	0.46	0.60
3	0.44	0.59
4	0.42	0.57
5	0.40	0.55
6	0.38	0.54
7	0.36	0.52
8	0.34	0.50
9	0.32	0.48
10	0.30	0.47
11	0.28	0.45
12	0.26	0.43
13	0.24	0.42
14	0.22	0.40
15	0.20	0.38

**Size-Specific SHGC Matrix:  
NFRC Standard Size (78.740" x 78.740")<sup>5</sup>**

Center-of-Glass SHGC	Overall SHGC
0.75	0.69
0.70	0.65
0.65	0.60
0.60	0.56
0.55	0.51
0.50	0.47
0.45	0.42
0.40	0.38
0.35	0.33
0.30	0.29
0.25	0.24
0.20	0.20
0.15	0.15
0.10	0.11
0.05	0.06

**Size-Specific VT Matrix:  
NFRC Standard Size (78.740" x 78.740")<sup>5</sup>**

Center-of-Glass VT	Overall VT
0.75	0.67
0.70	0.63
0.65	0.58
0.60	0.54
0.55	0.49
0.50	0.45
0.45	0.40
0.40	0.36
0.35	0.31
0.30	0.27
0.25	0.22
0.20	0.18
0.15	0.13
0.10	0.09
0.05	0.04

Notes:

- System U-Factors are determined in accordance with NFRC 100 and based on the standard NFRC specimen size equal to a height of 2000mm x a width of 2000mm (78¾" x 78¾").
- SHGC and VT values are determined in accordance with NFRC 200 and based on the standard NFRC specimen size equal to a height of 2000mm x a width of 2000mm (78¾" x 78¾").