

**AAMA 1503-98 THERMAL PERFORMANCE
TEST REPORT**
(Revised)

Rendered to:

CORAL ARCHITECTURAL PRODUCTS

SERIES/MODEL: PW251 Aluminum Storefront System

TYPE: Glazed Wall Systems (Site-built)

Summary of Results	
Thermal Transmittance (U-Factor)	0.43
Condensation Resistance Factor - Frame (CRF _f)	66
Condensation Resistance Factor - Glass (CRF _g)	68
Unit Size	78-3/4" x 78-3/4" (2000 mm x 2000 mm)
Layer 1	1/4" Solar Cool Gray Tempered
Gap 1	0.47" Gap, Super Spacer (ZF-S), Air-Filled*
Layer 2	1/4" AGC TiAC 40 (e=0.040*, #3)

Reference must be made to Report No. 88820.02-116-46, dated 01/29/09 for complete test specimen description and data.

AAMA 1503-98 THERMAL PERFORMANCE TEST REPORT

(Revised)

Rendered to:

CORAL ARCHITECTURAL PRODUCTS
3010 Rice Mine Road
Tuscaloosa, Alabama 35406

Report Number: 88820.02-116-46
Test Date: 01/26/09
Report Date: 01/27/09
Expiration Date: 01/26/13
Revised Report Date: 01/28/09

Test Sample Identification:

Series/Model: PW251 Aluminum Storefront System

Type: Glazed Wall Systems (Site-built)

Test Sample Submitted by: Client

Test Procedure: The condensation resistance factor (CRF) and thermal transmittance (U) were determined in accordance with AAMA 1503-98, *Voluntary Test Method for Thermal Transmittance and Condensation Resistance of Windows, Doors and Glazed Wall Sections*

- | | |
|---|---------|
| 1. Average warm side ambient temperature | 69.80 F |
| 2. Average cold side ambient temperature | -0.40 F |
| 3. 15 mph dynamic wind applied to test specimen exterior. | |
| 4. 0.0" \pm 0.04" static pressure drop across specimen. | |

Test Results Summary:

- | | |
|---|------|
| 1. Condensation resistance factor - Frame (CRF _f) | 66 |
| Condensation resistance factor - Glass (CRF _g) | 68 |
| 2. Thermal transmittance due to conduction (U _c) | 0.43 |
| (U-factors expressed in Btu/hr·ft ² ·F) | |

Test Sample Description:

CONSTRUCTION	Frame
Size (in.) Non-Standard	78-3/4" x 78-3/4"
Daylight Opening (in.)	35-5/8" x 73-7/8" (x2)
CORNERS	Butted
Fasteners	Screws
Sealant	Yes
MATERIAL	AU (0.16")
Color Exterior	Gray
Finish Exterior	Anodized
Color Interior	Gray
Finish Interior	Anodized
GLAZING METHOD	Exterior pressure plate

Glazing Information:

Layer 1	1/4" Solar Cool Gray Tempered
Gap 1	0.47" Gap, Super Spacer (ZF-S), Air-Filled*
Layer 2	1/4" AGC TiAC 40 (e=0.040*, #3)
Gas Fill Method	Single-Probe Timed*
Desiccant	Yes

**Stated per Client/Manufacturer*

NA Non-Applicable

See Description Table Abbreviations

Test Sample Description: (Continued)

COMPONENTS		
Type	Quantity	Location
WEATHERSTRIP		
EPDM Gasket	3 Rows	Exterior pressure plates
EPDM Gasket	1 Row	Interior and exterior glazing perimeters
HARDWARE		
Aluminum pressure plates	7	Three vertical, four horizontal at exterior jambs, head and sill
Aluminum pressure plate cap	7	Three vertical, four horizontal at pressure plates
Aluminum trim cap	4	Interior head and sill
DRAINAGE		
No visible weeps		

Test Duration:

1. The environmental systems were started at 15:50 hours, 01/25/09.
2. The thermal performance test results were derived from 03:49 hours, 01/26/09 to 07:49 hours, 01/26/09.

Condensation Resistance Factor (CRF):

The following information, condensed from the test data, was used to determine the condensation resistance factor:

T_h	=	Warm side ambient air temperature	69.80 F
T_c	=	Cold side ambient air temperature	-0.40 F
FT_p	=	Average of pre-specified frame temperatures (14)	46.30 F
FT_r	=	Average of roving thermocouples (4)	39.33 F
W	=	$(FT_p - FT_r) / [FT_p - (T_c + 10)] \times 0.40$	0.076
FT	=	$FT_p(1-W) + W (FT_r) =$ Frame Temperature	45.77 F
GT	=	Glass Temperature	47.63 F
CRF_g	=	Condensation resistance factor – Glass	68
		$CRF_g = (GT - T_c) / (T_h - T_c) \times 100$	
CRF_f	=	Condensation resistance factor – Frame	66
		$CRF_f = (FT - T_c) / (T_h - T_c) \times 100$	

The CRF number was determined to be 66 (on the size as reported). When reviewing this test data, it should be noted that the frame temperature (FT) was colder than the glass temperature (GT) therefore controlling the CRF number. Refer to the 'CRF Report' page and the 'Thermocouple Location Diagram' page of this report.

Thermal Transmittance (U_c):

T_h	= Average warm side ambient temperature	69.80 F
T_c	= Average cold side ambient temperature	-0.40 F
P	= Static pressure difference across test specimen 15 mph dynamic perpendicular wind at exterior	0.00 psf
	Nominal sample area	43.07 ft ²
	Total measured input to calorimeter	1428.02 Btu/hr
	Calorimeter correction	118.25 Btu/hr
	Net specimen heat loss	1309.77 Btu/hr
U_c	= Thermal Transmittance	0.43 Btu/hr·ft ² ·F

Glazing Deflection (in.):

	Left Glazing	Right Glazing
Edge Gap Width	0.49	0.49
Estimated center gap width upon receipt of specimen in laboratory (after stabilization)	0.49	0.49
Center gap width at laboratory ambient conditions on day of testing	0.49	0.49
Center gap width at test conditions	0.38	0.41

The sample was inspected for the formation of frost or condensation, which may influence the surface temperature measurements. The sample showed no evidence of condensation/frost at the conclusion of the test.

A calibration of the Architectural Testing Inc. 'thermal test chamber' (ICN 000001) in York, Pennsylvania was conducted in April 2008 in accordance with Architectural Testing Inc. calibration procedure.

Prior to testing the specimen was sealed with silicone on the interior side and checked for air infiltration per Section 9.3.4.



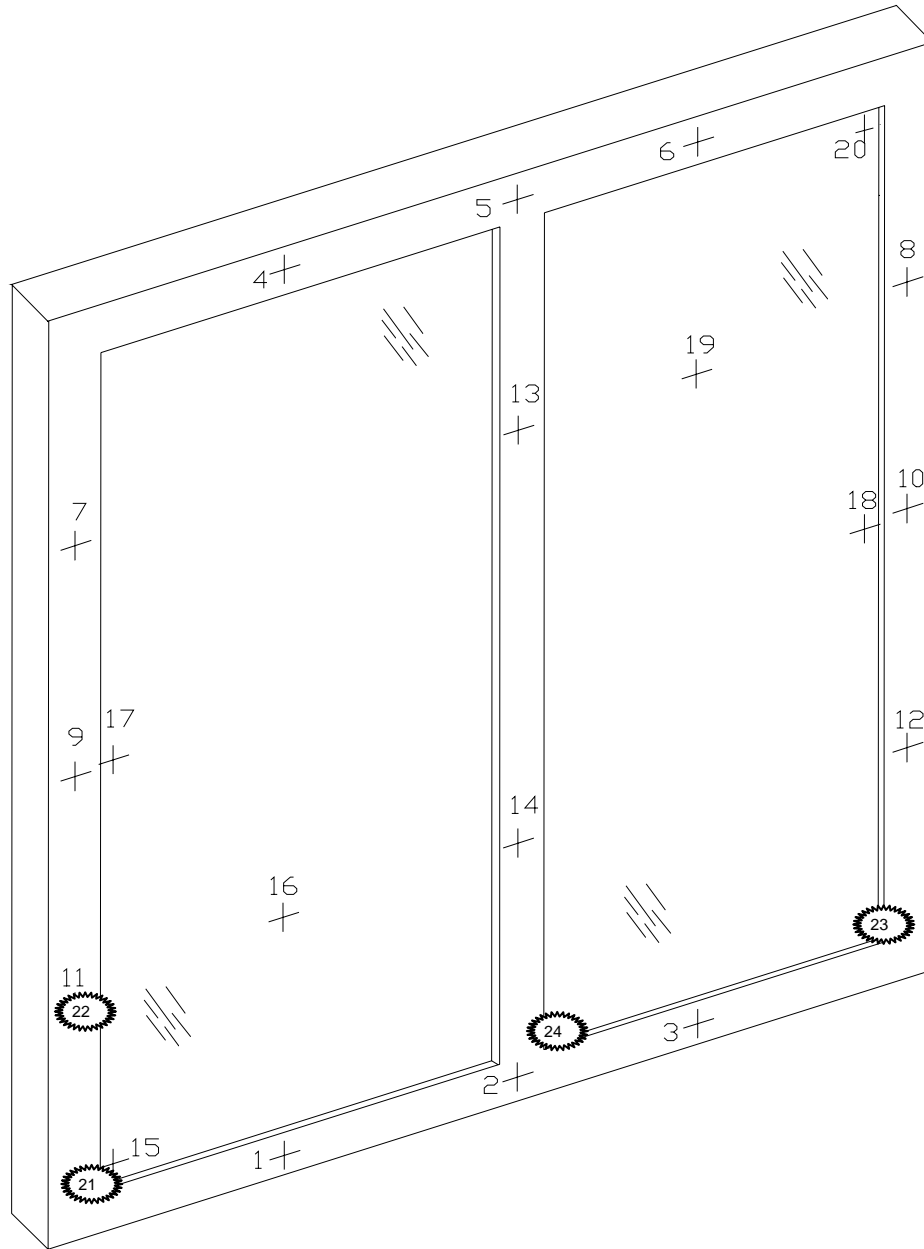

CRF Report

Time:	05:49	06:19	06:49	07:19	07:49	AVERAGE
Pre-specified Thermocouples - Frame						
1	43.19	43.17	43.15	43.18	43.16	43.17
2	44.81	44.80	44.79	44.81	44.80	44.80
3	43.19	43.17	43.15	43.18	43.16	43.17
4	51.15	51.11	51.11	51.14	51.11	51.12
5	51.55	51.58	51.54	51.56	51.61	51.57
6	50.78	50.82	50.86	50.82	50.81	50.82
7	46.57	46.58	46.57	46.60	46.59	46.58
8	45.29	45.31	45.30	45.30	45.31	45.30
9	42.83	42.84	42.81	42.82	42.84	42.83
10	45.48	45.49	45.46	45.46	45.47	45.47
11	39.16	39.21	39.19	39.18	39.18	39.18
12	44.09	44.09	44.11	44.10	44.08	44.09
13	52.73	52.73	52.76	52.77	52.76	52.75
14	47.34	47.30	47.28	47.33	47.33	47.31
FTP	46.30	46.30	46.29	46.30	46.30	46.30
Pre-specified Thermocouples - Glass						
15	36.46	36.43	36.43	36.46	36.42	36.44
16	53.23	53.20	53.23	53.24	53.23	53.23
17	46.55	46.57	46.56	46.56	46.60	46.57
18	48.33	48.32	48.33	48.34	48.35	48.34
19	54.90	54.88	54.89	54.88	54.89	54.89
20	46.35	46.34	46.33	46.35	46.34	46.34
GT	47.64	47.62	47.63	47.64	47.64	47.63
Cold Point (Roving) Thermocouples						
21	35.70	35.70	35.70	35.70	35.70	35.70
22	39.20	39.20	39.20	39.20	39.20	39.20
23	40.50	40.50	40.50	40.50	40.50	40.50
24	41.90	41.90	41.90	41.90	41.90	41.90
FT _R	39.33	39.33	39.33	39.33	39.33	39.33
W	0.08	0.08	0.08	0.08	0.08	0.08
FT	45.77	45.77	45.76	45.77	45.77	45.77
Warm Side - Room Ambient Air Temperature						
	69.80	69.80	69.80	69.80	69.80	69.80
Cold Side - Room Ambient Air Temperature						
	-0.45	-0.40	-0.41	-0.41	-0.37	-0.40
CRF _f	66	66	66	66	66	66
CRF _g	68	68	68	68	68	68

Thermocouple Location Diagram



Cold Point Locations

	21. 35.70
	22. 39.20
	23. 40.50
	24. 41.90

Detailed drawings, data sheets, representative samples of the test specimens, a copy of this report, or other pertinent project documentation will be retained by Architectural Testing, Inc. until 1/26/2013. At the end of this retention period such materials shall be discarded without notice and the service life of this report by Architectural Testing, Inc. will expire.

Results obtained are tested values and were secured by using the designated test methods. This report does not constitute certification of this product nor an opinion or endorsement by this laboratory. It is the exclusive property of the client so named herein and relates only to the specimen(s) tested. This report may not be reproduced, except in full, without the written approval of Architectural Testing, Inc.

For ARCHITECTURAL TESTING, INC.

Ryan P. Moser
Technician

Shon W. Einsig
Senior Technician
Individual-In-Responsible-Charge

RPM:kmm
88820.02-116-46

Attachments (pages): This report is complete only when all attachments listed are included.
Appendix-A: Description Table Abbreviations (1)
Appendix-B: Drawings (1)

Revision Log

<u>Rev. #</u>	<u>Date</u>	<u>Page(s)</u>	<u>Revision(s)</u>
.02R0	01/27/09	All	Original Report Issue. Work requested by David Welch of Coral Architectural Products.
.02R1	01/28/09	Cover, 2	Changed Gas Fill from Argon to Air Filled

Appendix A: Description Table Abbreviations

CODE	Frame / Sash Types
AI	Aluminum w/ Vinyl Inserts (Caps)
AL	Aluminum
AP	Aluminum w/ Thermal Breaks - Partial
AS	Aluminum w/ Steel Reinforcement
AT	Aluminum w/ Thermal Breaks - All Members (> 0.21")
AU	Aluminum Thermally Improved - All Members (0.062" - 0.209")
AV	Aluminum / Vinyl Composite
AW	Aluminum-clad Wood
FG	Fiberglass
PA	ABS Plastic w/ All Members Reinforced
PC	ABS Plastic-clad Aluminum
PF	ABS Plastic w/ Foam-filled Insulation
PH	ABS Plastic w/ Horizontal Members Reinforced
PI	ABS Plastic w/ Reinforcement - Interlock
PL	ABS Plastic
PP	ABS Plastic w/ Reinforcement - Partial
PV	ABS Plastic w/ Vertical Members Reinforced
PW	ABS Plastic-clad Wood
ST	Steel
VA	Vinyl w/ All Members Reinforced
VC	Vinyl-clad Aluminum
VF	Vinyl w/ Foam-filled Insulation
VH	Vinyl w/ Horizontal Members Reinforced
VI	Vinyl w/ Reinforcement - Interlock
VP	Vinyl w/ Reinforcement - Partial
VV	Vinyl w/ Vertical Members Reinforced
VW	Vinyl-clad Wood
VY	Vinyl
WA	Aluminum / Wood composite
WD	Wood
WV	Vinyl / Wood composite
WF	Fiberglass/Wood Combination
WC	Composite/Wood Composite (Shaped vinyl/wood composite members)
CW	Copper Clad Wood
CO	Vinyl/Wood Composite Material

DOOR DETAILS	
N	Not Applicable
CODE	Door Type
EM	Embossed
FL	Flush
LF	Full Lite
LH	1/2 - Lite
LQ	1/4 - Lite
LT	3/4 - Lite
RP	Raised Panel
CODE	Skin
AL	Aluminum
FG	Fiberglass
GS	Galvanized Steel
ST	Steel
WD	Wood
VY	Vinyl
CODE	Panel
FG	Fiberglass
PL	Plastic
WP	Wood - Plywood
WS	Wood - Solid
CODE	Sub-Structure
GS	Galvanized Steel
ST	Steel
WD	Wood
VY	Vinyl
CODE	Core Fill
CH	Cellular - Honeycomb
EP	Expanded Polystyrene
PI	Polyisocyanurate
PU	Polyurethane
WP	Wood - Plywood
WS	Wood - Solid
XP	Extruded Polystyrene

CODE	Spacer Types (See sealant)
A1	Aluminum
A2	Aluminum (Thermally-broken)
A3	Aluminum-reinforced Polymer
A4	Aluminum / Wood
A5	Aluminum-reinforced Butyl (Swiggle)
A6	Aluminum / Foam / Aluminum
A7	Aluminum U-shaped
A8	Aluminum-Butyl (Corrugated) (Duraseal)
ER	EPDM Reinforced Butyl
FG	Fiberglass
GL	Glass
OF	Organic Foam
P1	Duralite
PU	Polyurethane Foam
SU	Stainless Steel, U-shaped
CU	Coated Steel, U-shaped (Intercept)
S2	Steel (Thermally-broken)
S3	Steel / Foam / Steel
S5	Steel-reinforced Butyl
S6	Steel U-channel w/ Thermal Cap
SS	Stainless Steel
CS	Coated Steel
TP	Thermo-plastic
WD	Wood
ZE	Elastomeric Silicone Foam
ZF	Silicone Foam
ZS	Silicone / Steel
N	Not Applicable
TS	Thermo-plastic w/ stainless steel substrate

CODE	Tint Codes
AZ	Azurlite
BL	Blue
BZ	Bronze
CL	Clear
EV	Evergreen
GD	Gold
GR	Green
GY	Gray
LE	Low 'e' Coating
OT	Other (use comment field)
RC	Solar or Reflective Coating
RG	Roller Shades between glazing
RS	Silver (reflective coating)
SF	Suspended Polyester Film
SR	Silver
BG	Blinds between the Glazing
DV	Dynamic Glazing-Variable
DY	Dynamic Glazing-NonVariable

CODE	Gap Fill Codes
AIR	Air
AR2	Argon/Krypton Mixture
AR3	Argon / Krypton / Air
ARG	Argon/Air
CO2	Carbon Dioxide
KRY	Krypton/Air
SF6	Sulfur Hexafluoride
XE2	Xenon/Krypton/Air
XE3	Xenon/Argon/Air
XEN	Xenon/Air
N	Not Applicable

CODE	Spacer Sealant
D	Dual Seal Spacer System
S	Single Seal Spacer System

CODE	Grid Description
N	No Muntins
G	Grids between glass
S	Simulated Divided Lites
T	True Muntins

CODE	Grid Size Codes
	Blank for no grids
0.75	Grids < 1"
1.5	Grids >= 1"

CODE	Thermal Breaks
F	Foam
U	Urethane
V	Vinyl
FB	Fiberglass
O	Other
AB	ABS
NE	Neoprene
AI	Air
N	Not Applicable
P	Polyamide

Appendix B: Drawings

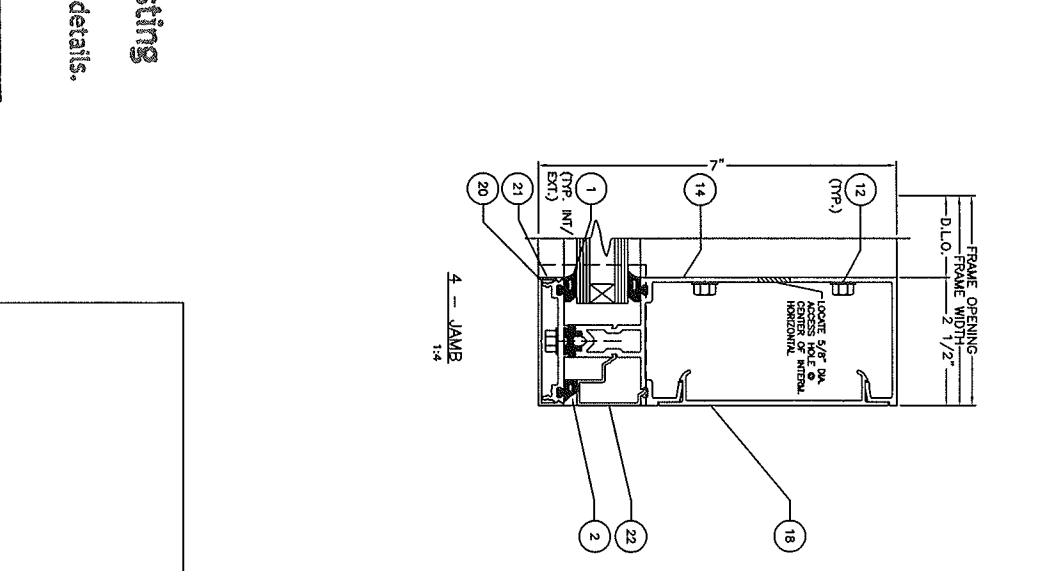
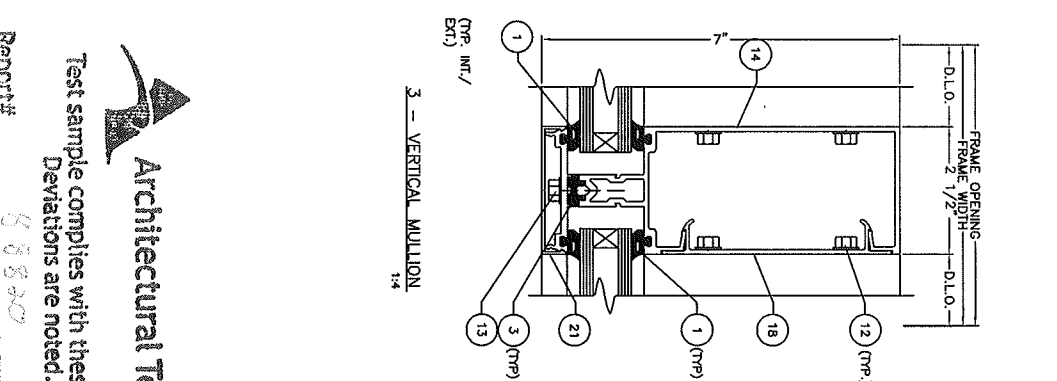
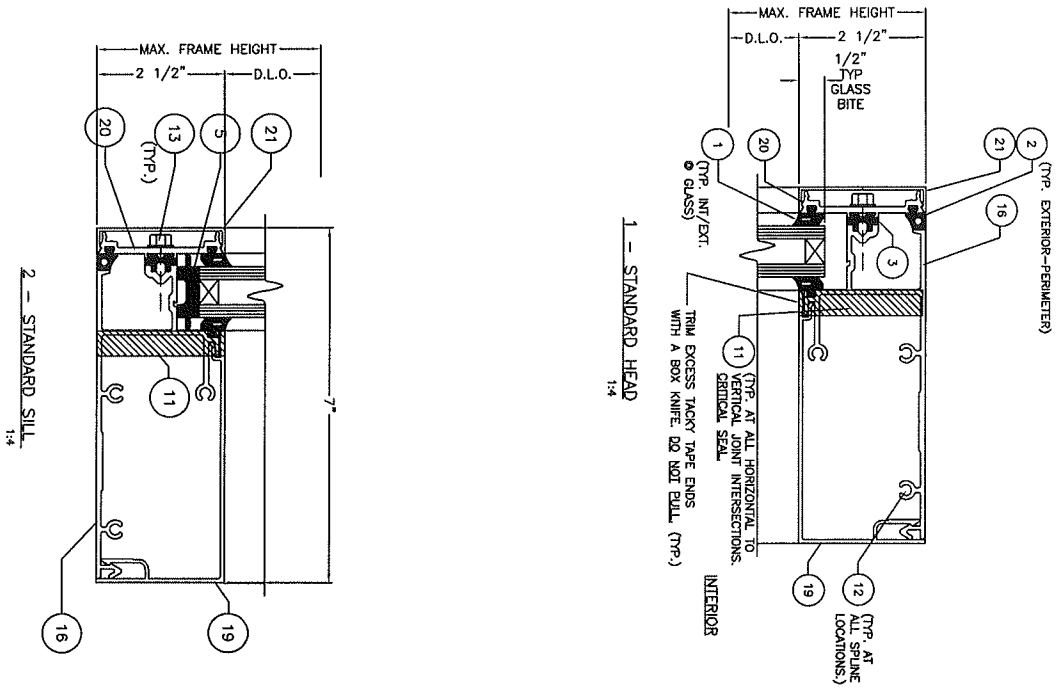

REV	BY	DATE	DESCRIPTION

THERMAL TEST REPORT
DRAWINGS FOR PW251 CURTAIN
WALL SYSTEM

FRAMING DETAILS

DATE: 1/18/2009
 DRAWN: [blank] / CHECKED: [blank]
 ALL: [blank] / DCNV: [blank]
 PROJECT NO.: [blank]
 DRAWING NO.: PW251T
 SHEET 3 OF 4

Architectural Testing

Test sample complies with these details.
Deviations are noted.

Report# 88830
 Date: 1/27/09 Tech: EBM