

FL600

STOREFRONT SYSTEM

INSTALLATION INSTRUCTIONS 2-1/4" x 6" for 1" Glass

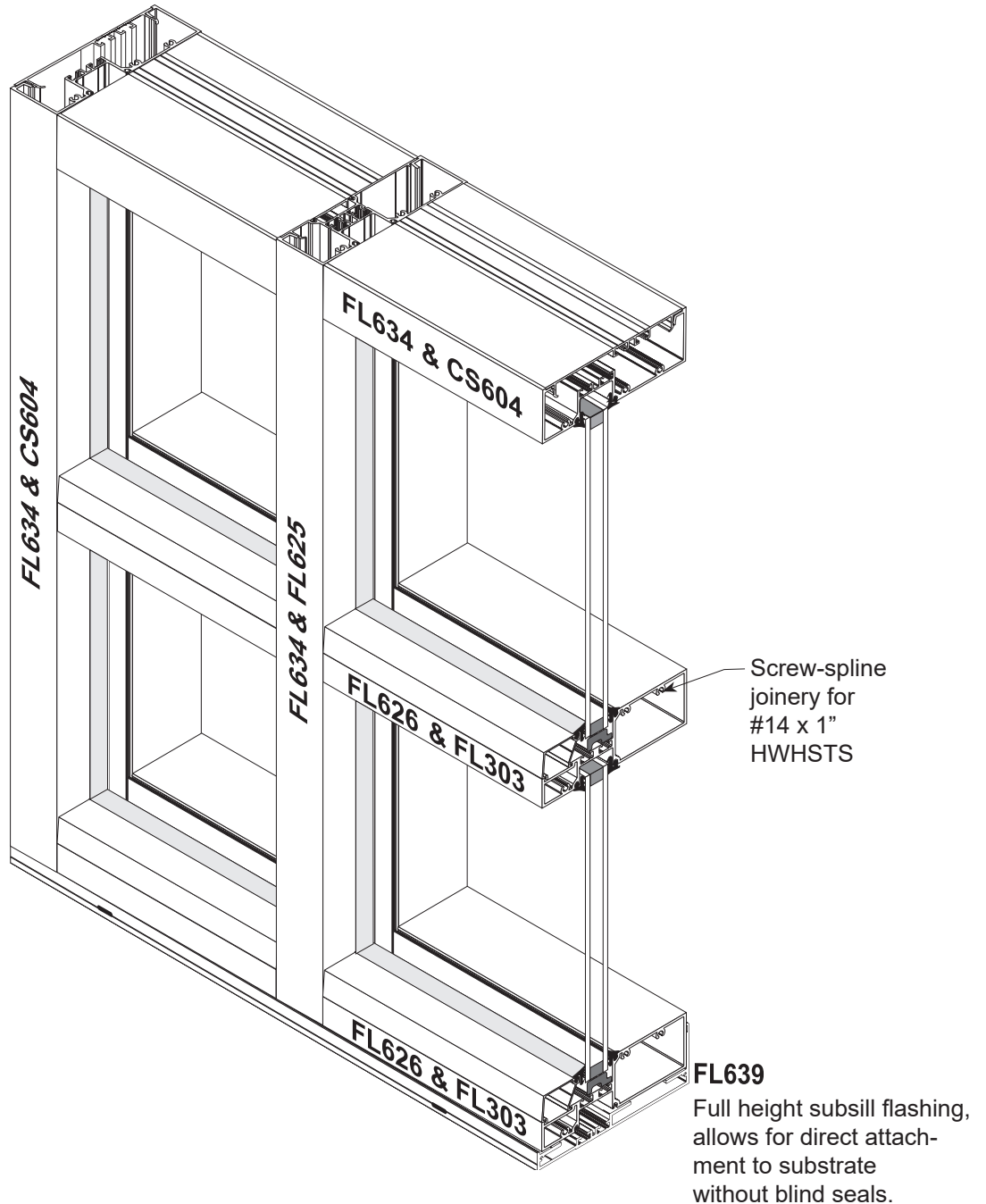

3010 Rice Mine Road, Tuscaloosa, Alabama 35406
1-800-772-7737 • Fax 1-800-443-6261 • www.coralap.com
A Division of Coral Industries, Inc.

Coral
Architectural Products











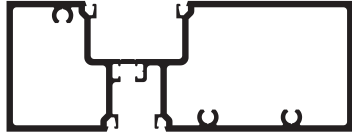

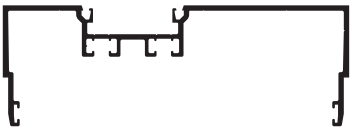
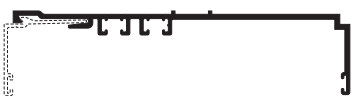
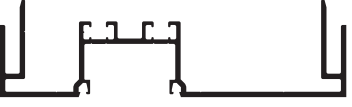
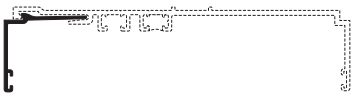

STOREFRONT SYSTEM

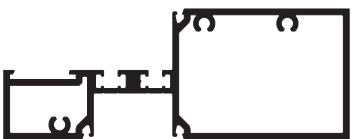
These instructions are for typical installations. Reference shop drawings for special notations on installations and glazing.

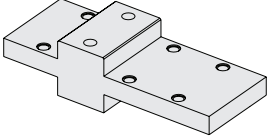

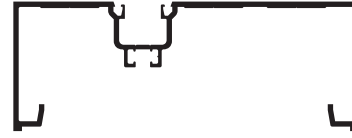











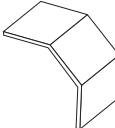

TABLE OF CONTENTS

	<i>Page</i>
FL600 System Parts.....	5-6
General Installation Information.....	7-8
Establish Frame Size.....	9
Frame Fabrication.....	10-15
Frame Assembly.....	16-18
Preperation of Door Frame.....	19
Frame Installation.....	20-25
Glass Formulas.....	26
Glazing.....	27-29
Door Preperation and Glazing.....	30-31
Special Conditions.....	32-35
Anchor Charts.....	36-41

FL600T SYSTEM PARTS

PARTS			
PART DESCRIPTION	PART NO.	PART DESCRIPTION	PART NO.
 Head/Jamb and Vertical (Deep Pocket)	FL634	 Door Header	FL607
 Flat Filler (Head/Wall Jamb)	CS604	 "F" Clip	CS601
 Filler (For Vertical)	FL625	 Expansion Mullion (Male)	FL610
 Head Expander	CS619	 Expansion Mullion (Female)	FL611
 Interlocking Stop (Snap fits with CS619 interlocking stop)	CS118	 Heavy Wall Frame Jamb	FL649
 Sill/Intermediate Horizontal	FL626	 Concealed Closer Header	FL612
 Glass Stop	FL303	 Drill Jig	DJ600
 Subsill	FL639	 Door Stop	DS200
 Door Jamb	FL609	 Door Stop	DS600
 Threshold	TH5BT	 Setting Block	SB3

FL600T SYSTEM PARTS

PARTS			
PART DESCRIPTION	PART NO.	PART DESCRIPTION	PART NO.
 FL518	FL518	 Weathering for D200	WP200
 CS115	CS115	 Schnee-Morehead SM5601 1/8" x 1/2" Tacky Tape	SM5601
 CS105	CS105	 EPDM Gasket (Standard Gasket for 1/4" Glazing)	NG1
 CS106	CS106	 Vinyl Gasket (Standard Weathering Gasket for FL210 and CS118 / CS119)	VG10
 CS107	CS107	 AS56	AS56
 CS108	CS108	 AS16	AS16
 CS109	CS109	 AS31	AS31
		 Water Diverter	WD300-1
		 End Dam	ED639

INSTALLATION INSTRUCTIONS - General Installation Information -

RECOMMENDED GUIDELINES FOR ALL INSTALLATIONS:

- 1. REVIEW CONTRACT DOCUMENTS.** Check shop drawings, installation instructions, architectural drawings and shipping lists to become thoroughly familiar with the project. The shop drawings take precedence and include specific details for the project. Field verified notations shown within shop drawings must be resolved prior to installation. The installation instructions are of general nature and cover most conditions.
- 2. INSTALLATION.** All materials shall be installed plumb, level and true.
- 3. BENCHMARKS.** All work should start from established benchmarks and column center lines established by the architect and general contractor.
- 4. FIELD WELDING.** All field welding must be adequately shielded to avoid any splatter on glass or aluminum. Advise general contractor and other trades accordingly. All field welds of steel anchors must receive touch-up paint (zinc chromate) to avoid rust.
- 5. SURROUNDING CONDITIONS.** Make certain that construction which will receive your materials is in accordance with the contract documents. If not, notify the general contractor in writing and resolve differences before proceeding with work.
- 6. ISOLATION OF ALUMINUM.** Aluminum to be placed in direct contact with uncured masonry or incompatible materials should be isolated with a heavy coat of zinc chromate or bituminous paint.
- 7. SEALANTS.** Sealants must be compatible with all materials with which they have contact, including other sealant surfaces. Consult with sealant manufacturer for recommendations relative to joint size, shelf life, compatibility, cleaning, priming, tooling, adhesion, etc. It is the responsibility of the Glazing Contractor to submit a statement from the sealant manufacturer indicating that glass and glazing materials have been tested for compatibility and adhesion with glazing sealants, and interpreting test results relative to material performance, including recommendations for primers and substrate preparation required to obtain adhesion. The chemical compatibility of all glazing materials and framing sealants with each other and with like materials used in glass fabrication must be established.
- 8. FASTENING.** Only those fasteners used within the system are specified in these instructions. Due to the varying perimeter conditions and performance requirements perimeter fasteners are not specified in these instructions. Reference the shop drawings or anchor charts for perimeter fasteners.
- 9. BUILDING CODES.** Due to the diversity in state, local and national codes that govern the design and application of architectural products, it is the responsibility of the architect, owner and installer to assure that products selected for use on each project comply with all the applicable building codes and laws. CORAL ARCHITECTURAL PRODUCTS exercises no control over the use or application of its products, glazing materials and operating hardware and assumes no responsibility thereof.
- 10. EXPANSION JOINTS.** Expansion joints and perimeter seals shown in these instructions and shop drawings are shown at normal size. Expansion mullion gaps should be based on temperature at time of installation.

INSTALLATION INSTRUCTIONS

- General Installation Information -

- 11. WATER HOSE TEST.** After a representative amount of the storefront system has been glazed (500 square feet) and the sealant has cured, a water hose test should be conducted in accordance with AAMA 501.2 specifications to check the installation. This test should be repeated every 500 square feet during the glazing operation. Note: This test procedure should not be used for entrance doors.
- 12. COORDINATION WITH OTHER TRADES.** Coordinate with the general contractor and sequence with other trades items which offset the storefront installation such as back-up walls, partitions, ceilings and mechanical ducts.
- 13. MATERIAL HANDLING:**
- A. SHOP
 - 1. Cardboard wrapped or paper interleaved material must be kept dry.
 - 2. Immediately remove aluminum from cardboard wrapped or paper interleaved materials should it get wet to prevent staining or etching aluminum finish.
 - 3. Check arriving materials for quantity and keep record of where various materials are stored.
 - B. JOB SITE
 - 1. Material at job site must be stored in a safe place well removed from possible damage by other trades.
 - 2. Cardboard wrapped or paper interleaved material must be kept dry. (See 13.A.2)
 - 3. Keep record of where various materials are stored.
 - 4. Protect materials after erection. Cement, plaster, mortar and other alkaline solutions are very harmful to the finish.
- 14. CARE AND MAINTENANCE.** Final cleaning of exposed aluminum surfaces should be done in accordance with AAMA. 609.1 for anodized aluminum and 610.1 for painted aluminum.

ESTABLISH FRAME SIZE

Establish Frame Size and Cut Metal to Length

STEP 1.

Measure width of rough opening.

- A. Measure opening at bottom.
- B. Measure opening at center.
- C. Measure opening at top.

The frame width will be the smallest dimension less 1/2" allowing for a minimum 1/4" caulk joint at each jamb.

Repeat process to determine frame height.

- A. Beginning on left side of opening, measure dimension from top to bottom.
- B. Repeat at center.
- C. Repeat at right side of opening.

The frame height will be the smallest dimension less 1-1/8" allowing 5/8" for FL639T subsill and a 1/4" caulk joint at the head and and a 1/4" shim and caulk beneath the subsill.

STEP 2.

Cut members to size.

- A. Cut subsill to frame dimension plus 1/4". The subsill at entrance locations will butt tight against door jambs and is cut 1/8" longer than width of side lights on either side of door frame.
- B. Wall jambs and intermediate vertical mullions are cut to frame height.
- C. Horizontal members are cut to D.L.O.
- D. Snap-on glass stops are cut D.L.O. minus (-) 1/16".

FRAME FABRICATION

STEP 3.

Mark location for horizontals on vertical extrusions and drill holes for screw spline. Reference **STEP 4** for correct orientation of drill jig.

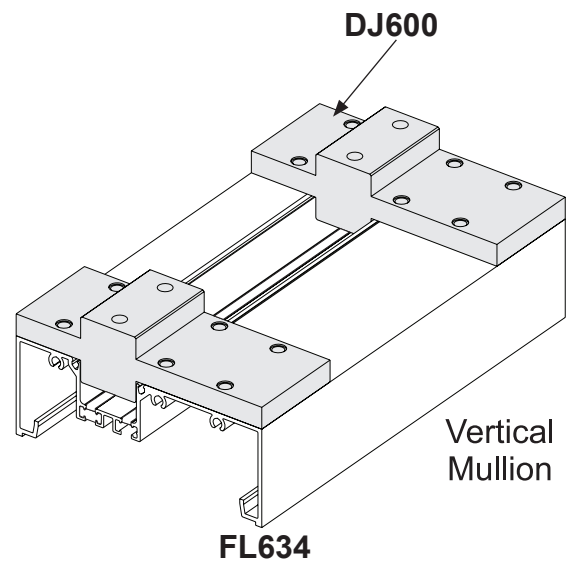
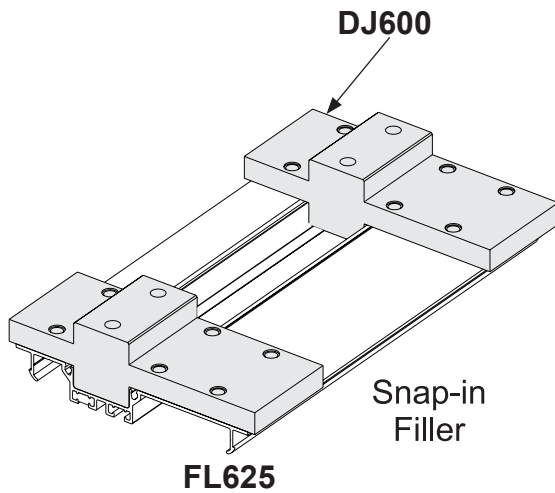

Note: Offset depth hands parts make sure to check handing of parts prior to any fabrication.

FRAME FABRICATION

STEP 4.

Drill or punch holes in verticals for attaching horizontals.

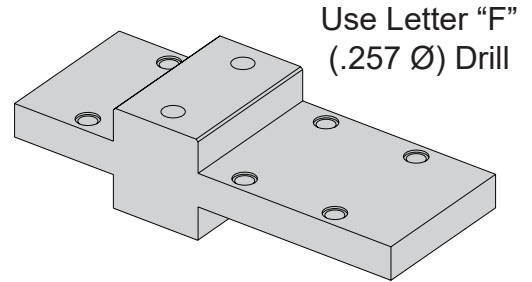
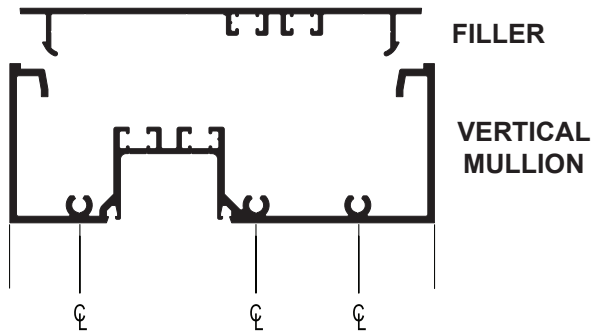

EXTERIOR GLAZING

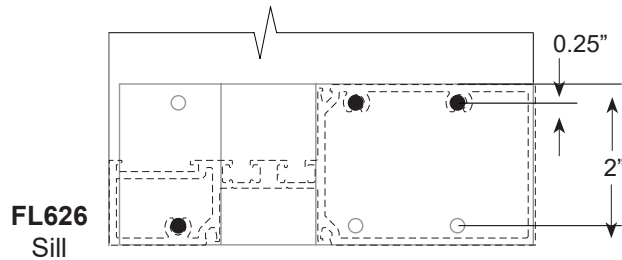
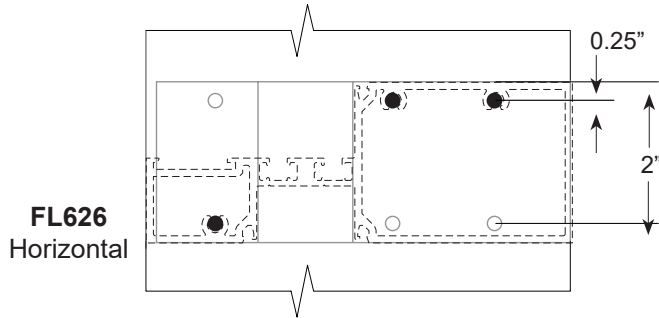
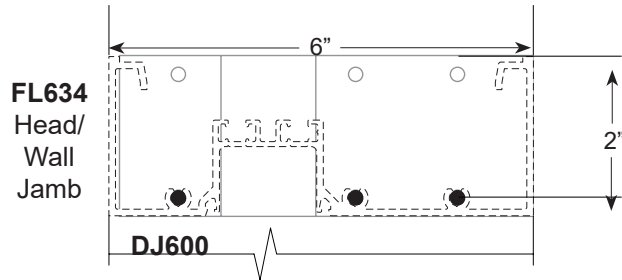

Note: Vertical at door jamb extends to floor

FRAME FABRICATION

STEP 6.

Fabricate head and sill anchor holes. Reference anchor charts for number of anchor holes and locations for each substrate. First hole is always 2" from end. Each additional fastener hole is located at required minimum spacing between fasteners based on substrate as shown in anchor charts. See page 35.

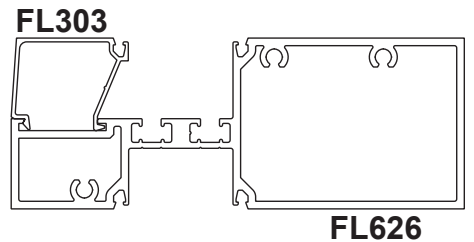
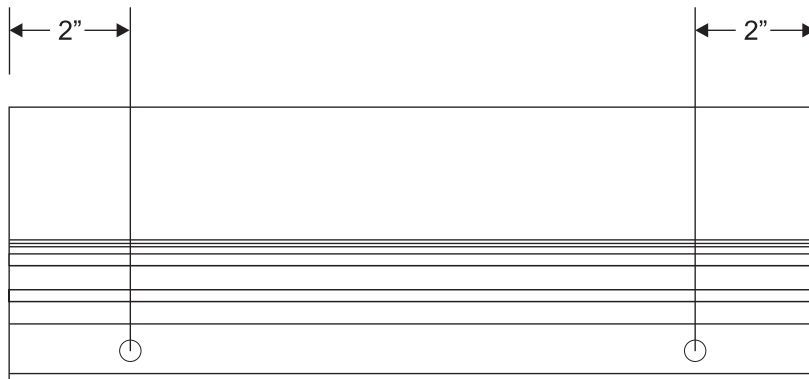
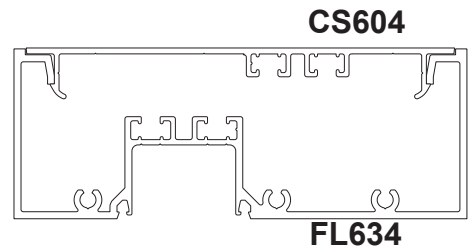
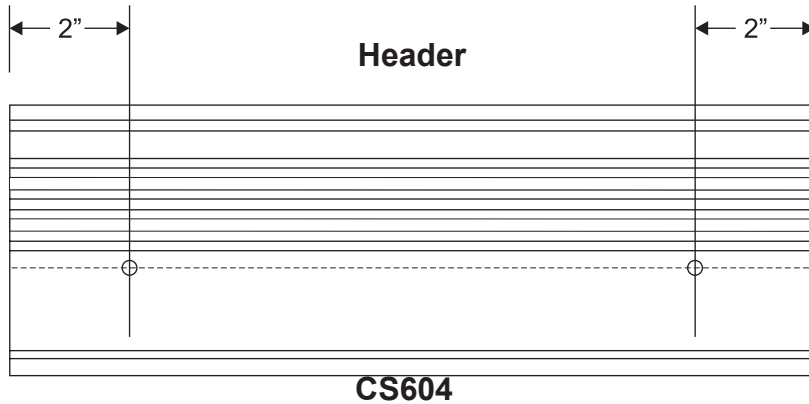

Drill 9/32" Ø clear hole for attaching **FL626** to **FL639** subsill with **AS56 1-1/4" x #12 SSPHPSMS** fastener.

FRAME FABRICATION

STEP 7.

Fabricate wall jamb for anchor holes when required. (**Reference Anchor Charts Page 37**) CS601 F clip can be used at this location in lieu of jamb anchors.

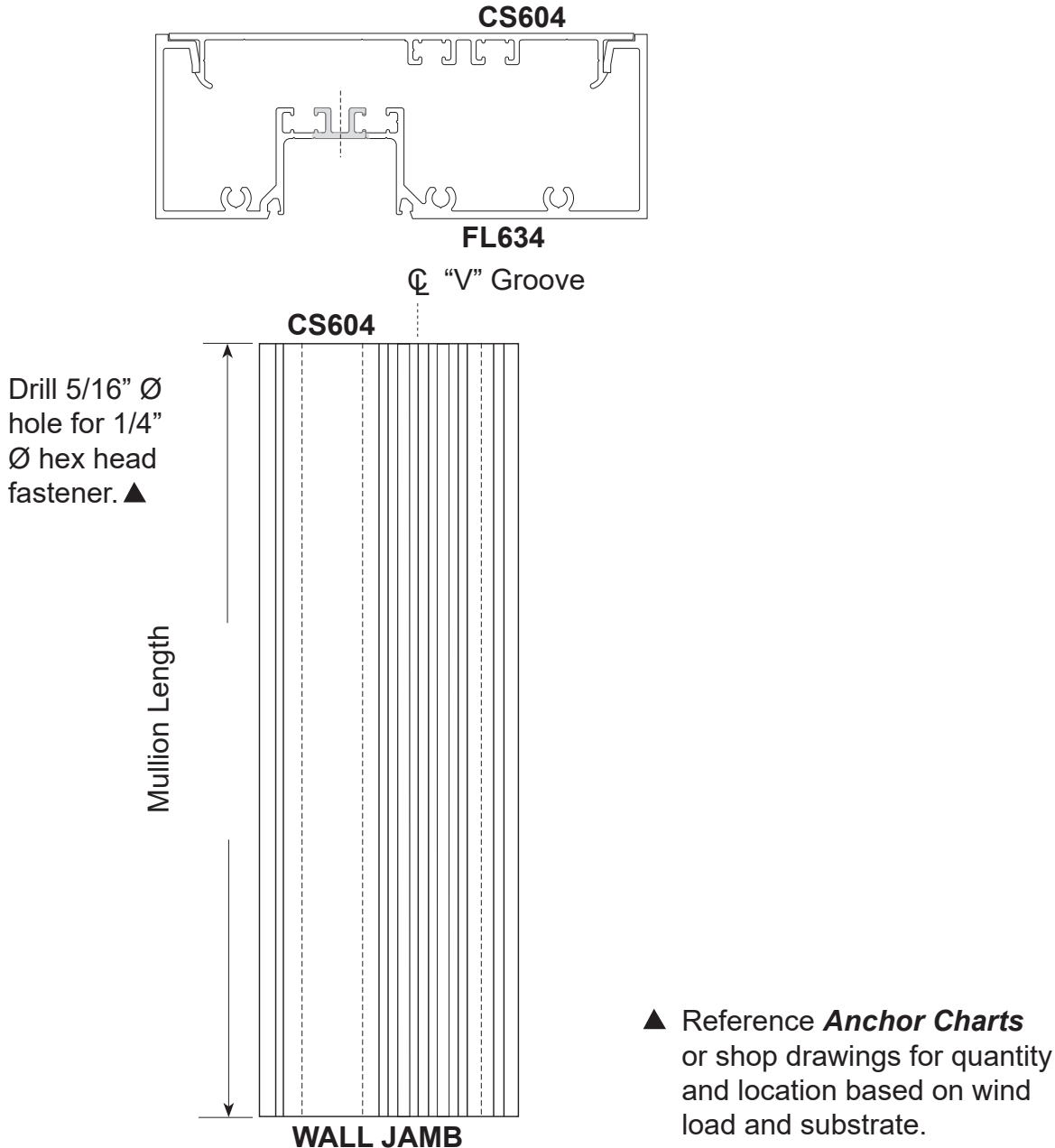

Note: Do not locate anchor holes at intersection of intermediate horizontal. Locate hole just above or below horizontal. Check anchor chart for spacing and quantity based on substrate.

FRAME FABRICATION

STEP 8.

Fabricate **FL639** subsill flashing for 1/4" Ø hex head structural fastener and weep holes. Hole location dimensions for fasteners in subsill are approximate. Drill 1/4" Ø weep holes as shown.

SUBSILL FLASHING

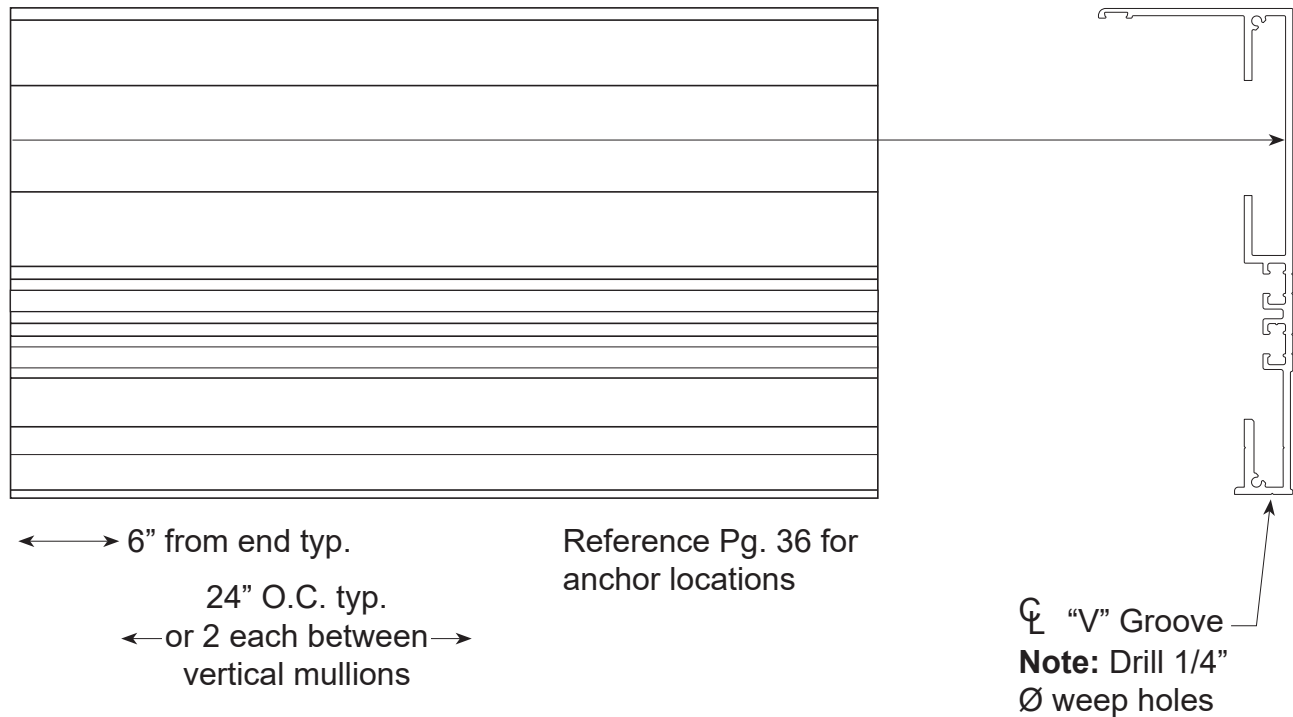

1. Drill 1/4" Ø weep holes in locations as shown. Locate one weep hole 6" from each end and additional holes approximately 48" on center. Total weep holes should average 2 each between each vertical mullion.

FRAME FABRICATION

Using Optional FL634 with CS619 and CS118
Not to be used in areas above 25PSF without PE Review

Note: CS118 is snapped on after frames are set in place

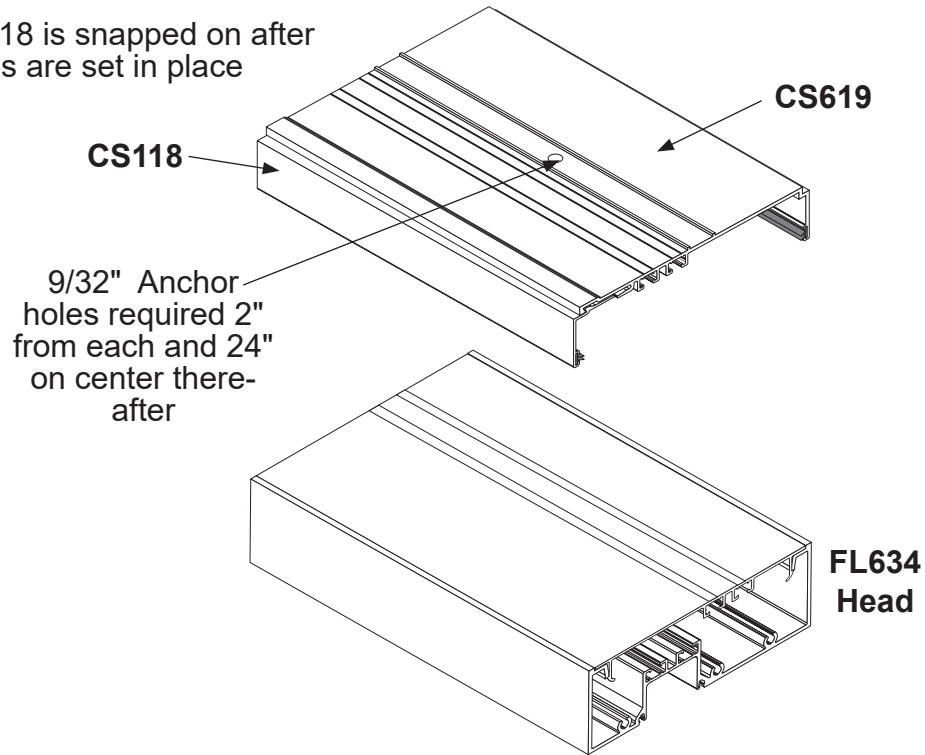

FRAME ASSEMBLY

Note: Wipe all surfaces with isopropyl alcohol to remove cutting oils and debris prior to applying SM5601 joint tape or sealants.

STEP 3.

AS31 (#6 x 3/8" PPH) Screw

SM5601 1/8" x 1/2" Tacky Tape

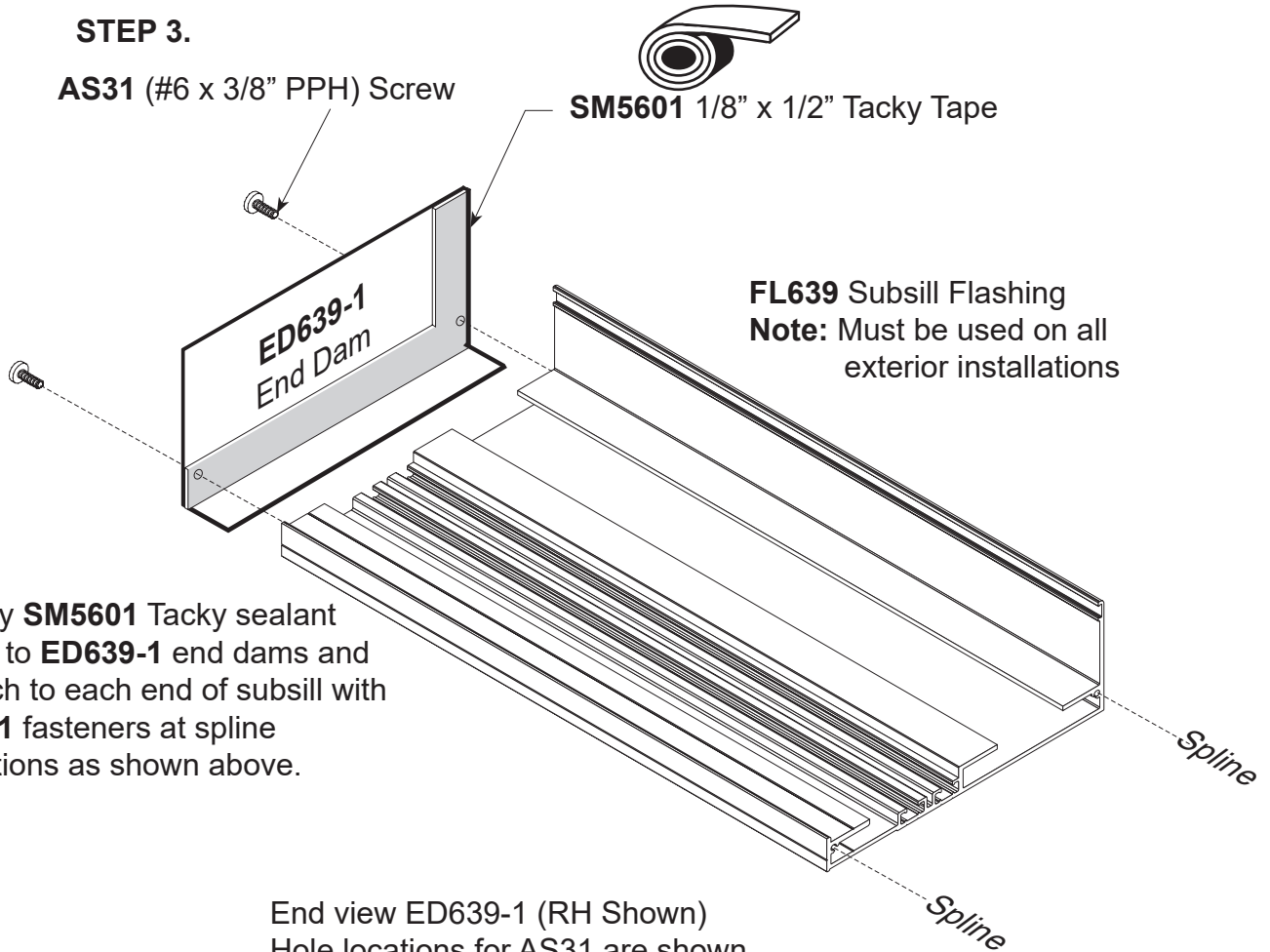

Apply **SM5601** Tacky sealant tape to **ED639-1** end dams and attach to each end of subsill with **AS31** fasteners at spline locations as shown above.

End view ED639-1 (RH Shown)
Hole locations for AS31 are shown below and are from the underside of ED639-1 End dam

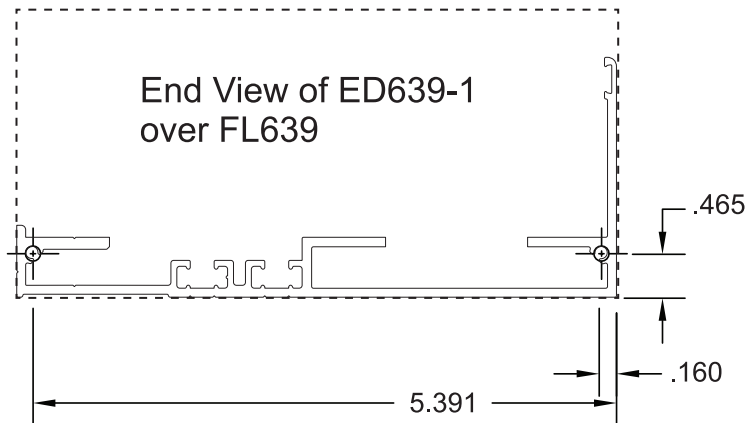

Locate holes as shown drill size required #21

FRAME ASSEMBLY - EXTERIOR GLAZING

Note: Wipe all surfaces with isopropyl alcohol to remove cutting oils and debris prior to applying SM5601 joint tape or sealants.

STEP 1.

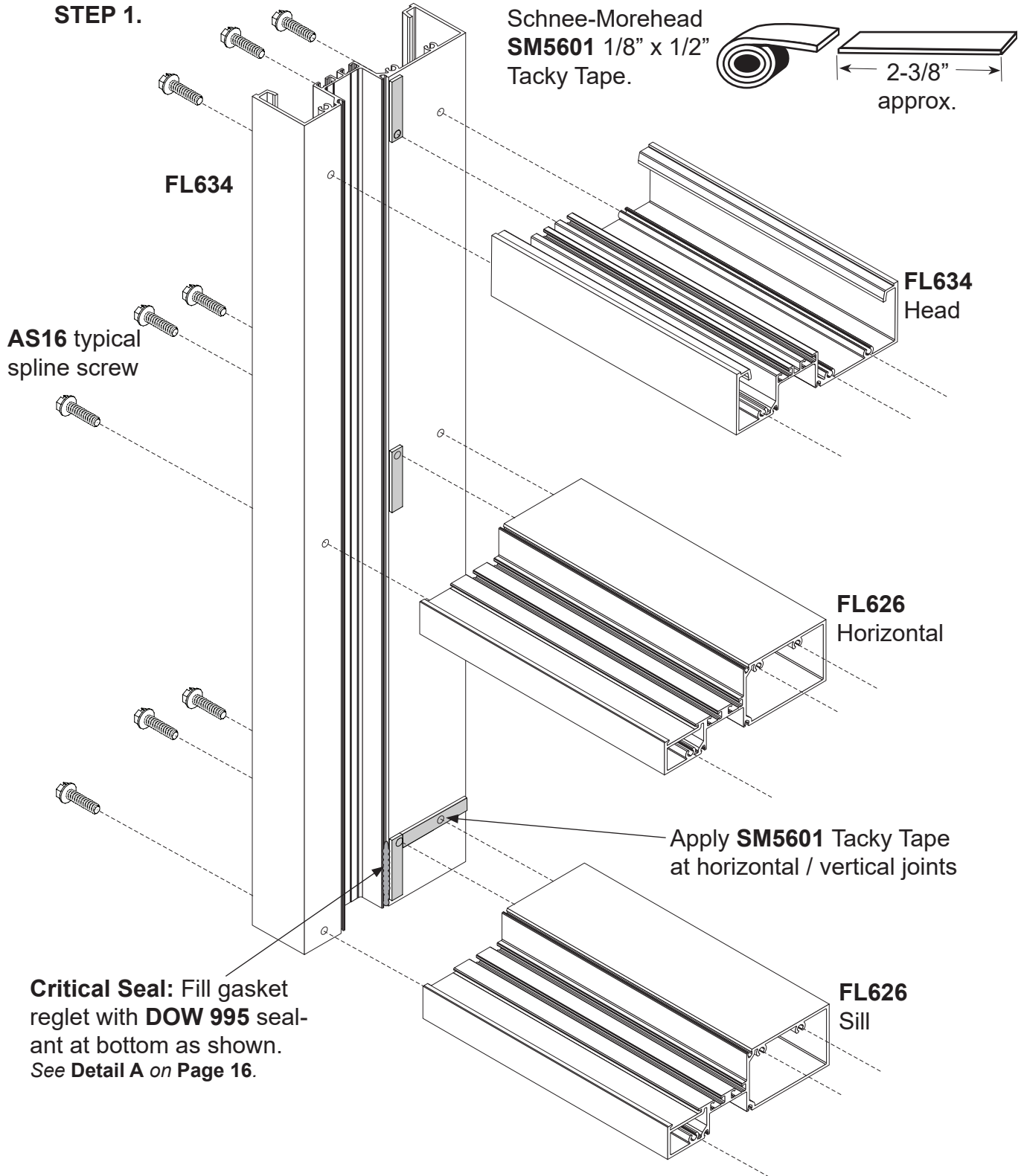

FRAME ASSEMBLY - EXTERIOR GLAZING

STEP 2.

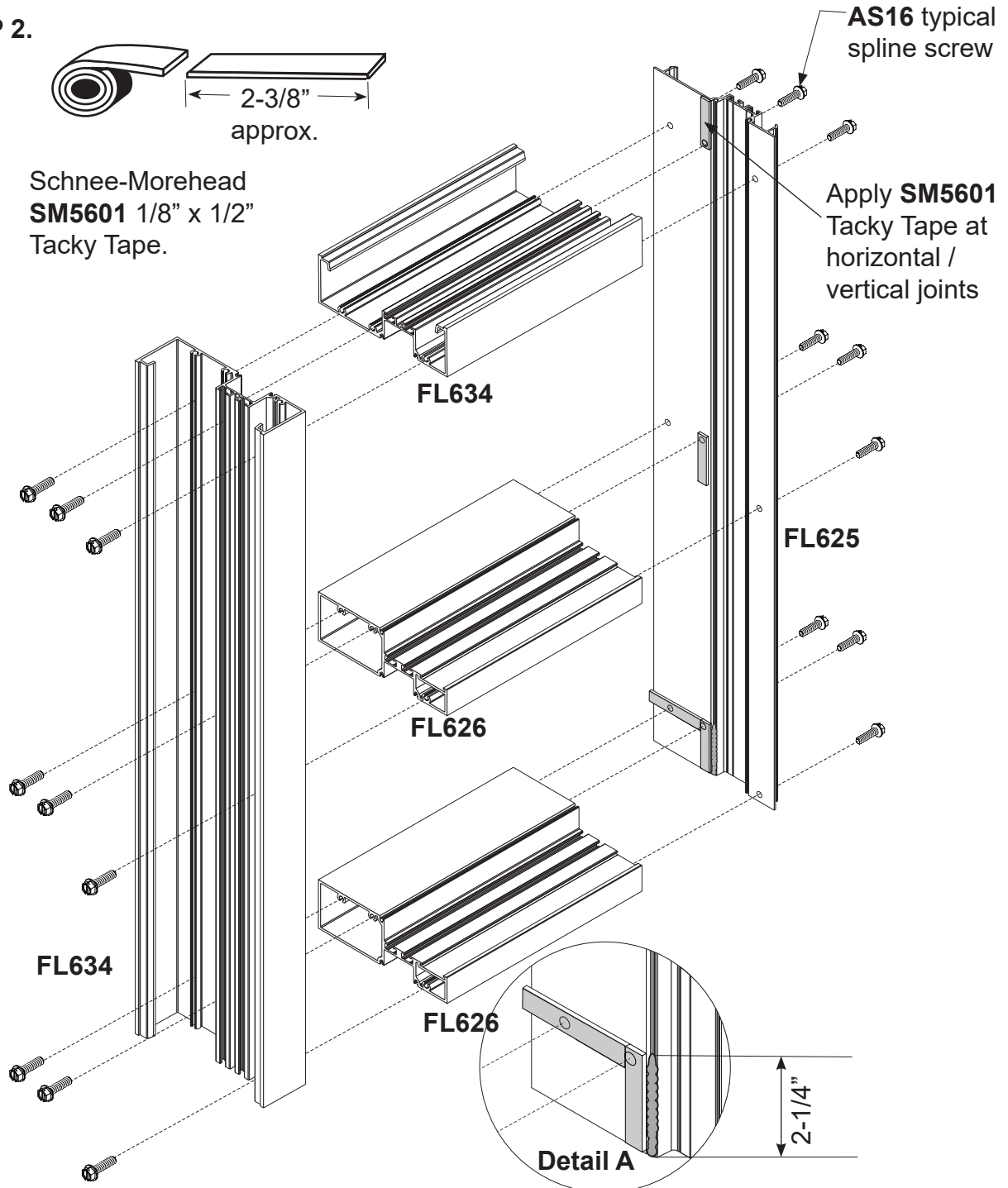

Attach horizontals to verticals using **AS16** (#14 x 1" HHSTS spline screws).
See **Page 7** for hole prep locations.

Critical Seal: Fill gasket reglet with **DOW 795** sealant at bottom as shown.

PREPARATION OF DOOR FRAME

All hardware back-up plates are installed in the frame at the factory. Door stops and transom sash are cut to length in the factory. Stock transom frames are fabricated for a vertical frame size of 10' - 5 1/2". If your transom opening is smaller, cut the verticals members down to the appropriate length. Leave a minimum 1/4" caulk joint at the head. The fabrication for the transom head horizontal should be made using either a drill fixture or punch die set for Series **FL600** framing. (See **Page 7** for **hole locations**). Review frame anchor charts for configuration and for substrate to which the frame will be attached. Drill anchor holes into door jamb at wall and **CS604** flat filler. Apply **SM5601** Tacky Tape to joint intersections at door header and transom head. Assemble frame with **AS16** spline screws. Use threshold clips as shown on **Page 19** for attaching threshold. Install transom sash if applicable. The frame is now ready for installation.

THRESHOLD FABRICATION

Note:
See *Entrances and Frames Installation Instructions* for detailed instructions.

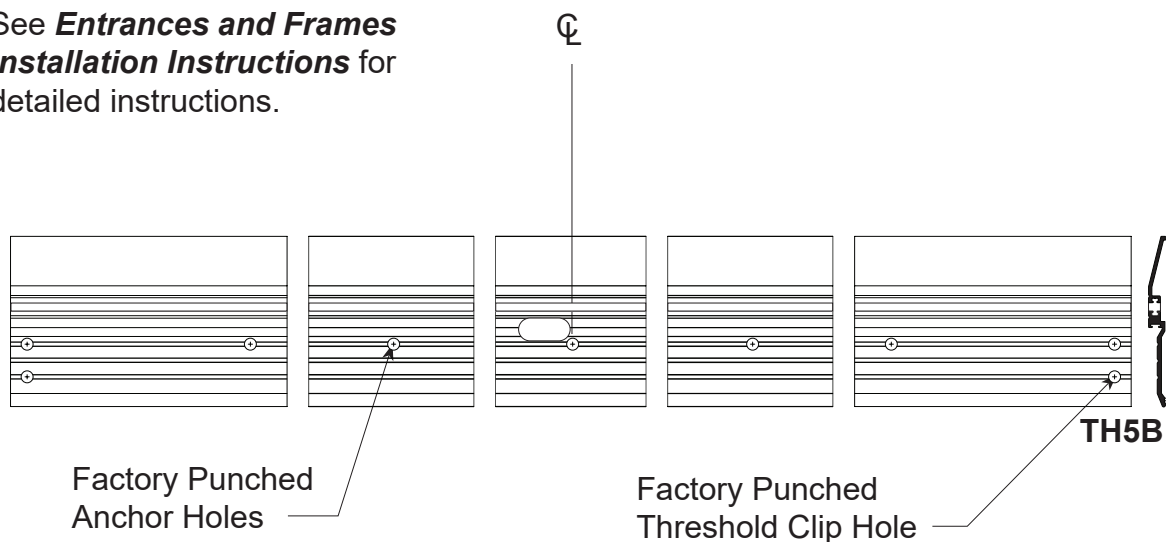

Threshold For Door Pair. (Butt Hung Shown, Offset Pivot Similar.)

INSTALLATION OF DOOR FRAME

1. Door frame and threshold shall be completely assembled with joints neatly aligned and tight.
2. Door frame shall be installed square and plumb. Measure frame diagonally from corner to corner and shim until the measurements are equal.
3. Level door frame threshold. The door frame is designed to have the jambs extend to floor.
4. Install fasteners through frame and threshold anchor holes and securely anchor to the substrate. Position shims between framing and substrate to prevent members from bowing.
5. Install door stops.
6. Install FL639T Subsill for sidelites as required.

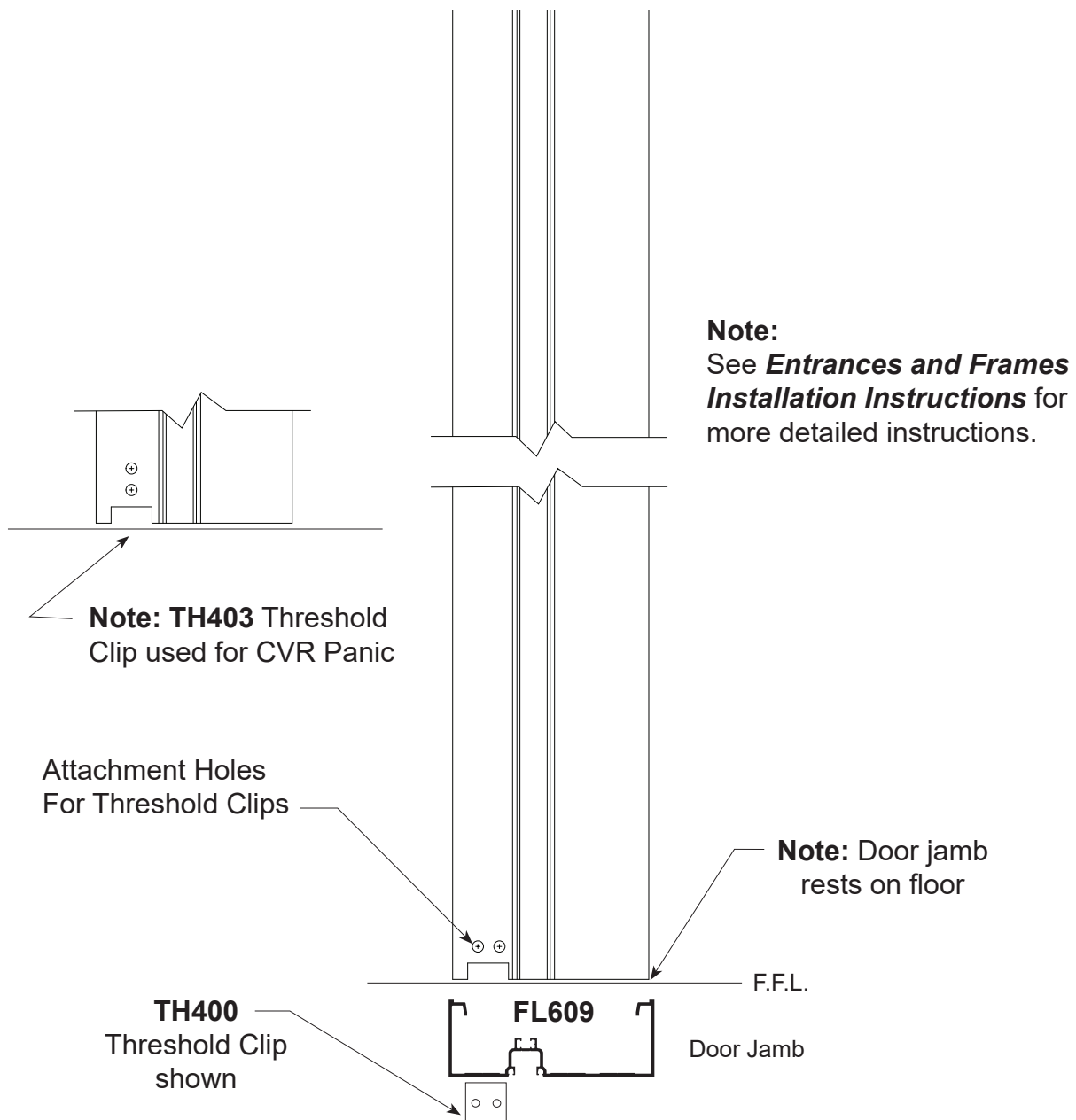

ENTRANCE DOOR FRAME INSTALLATION WITH SUBSILL FOR SIDELIGHTS

Where entrance doors occur, install entrance door frames first. Subsill butts against door jamb. The subsill abutting the door jamb does not require an end dam.

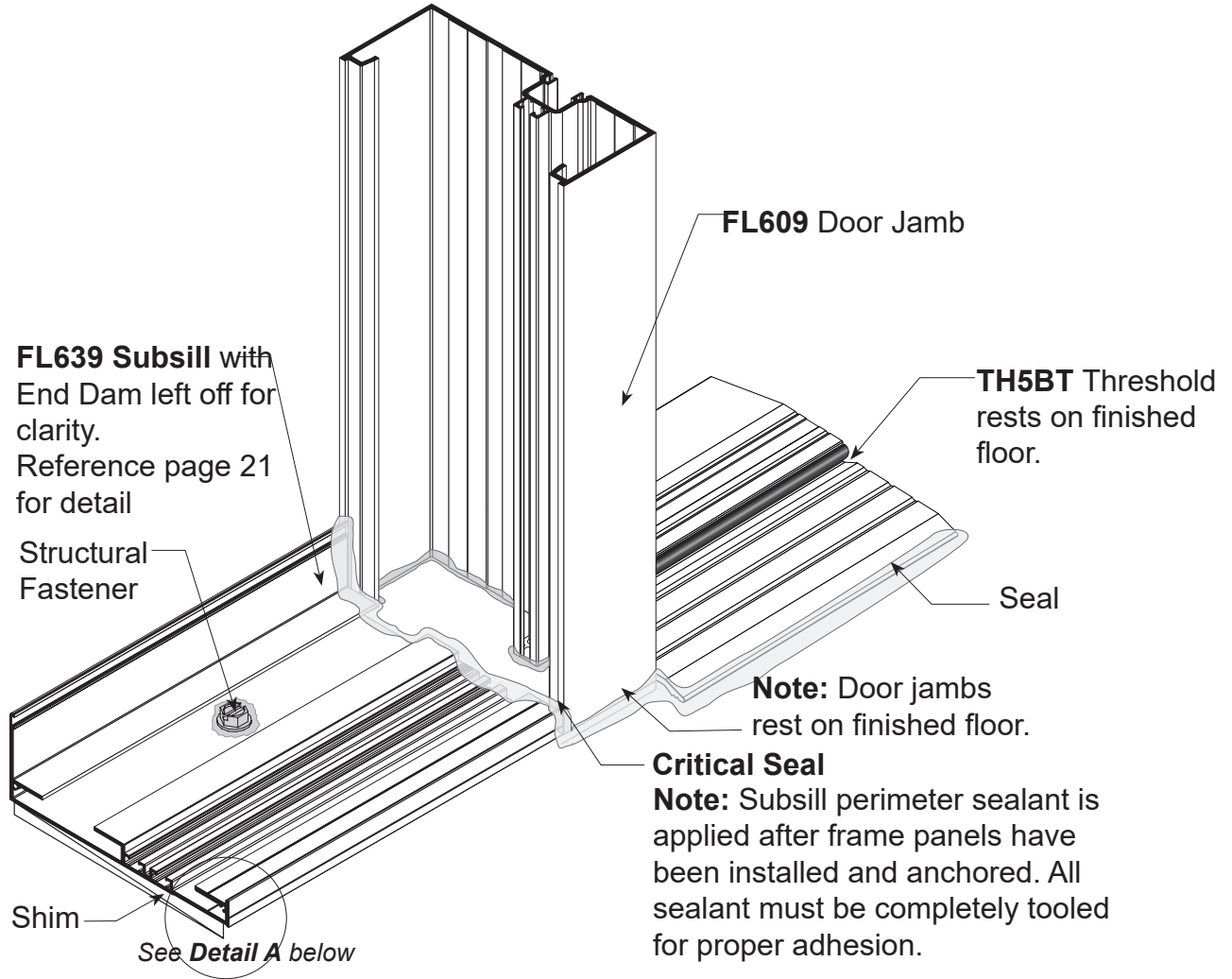

Detail A

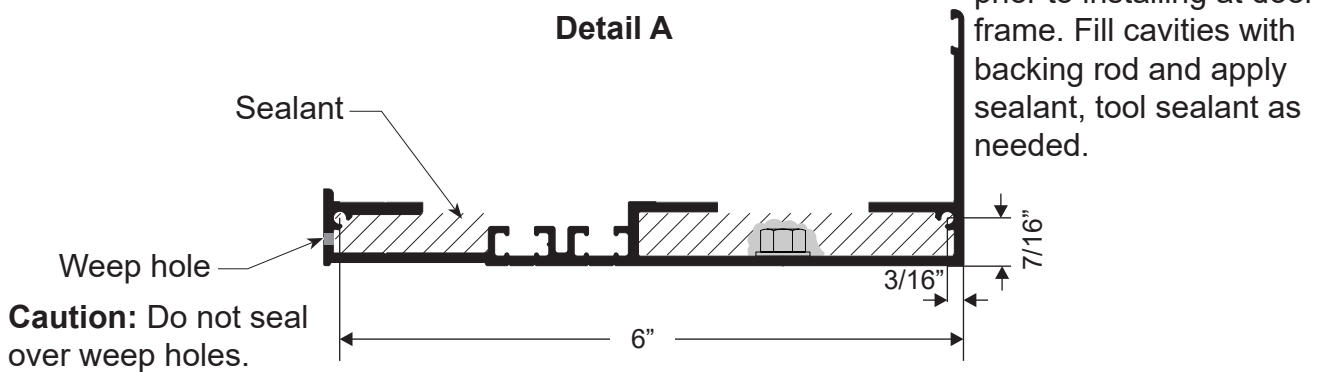

FRAME INSTALLATION

STEP 1.

Center subsill into opening allowing for a 1/4" minimum shim space at each end to ensure a good caulk joint.

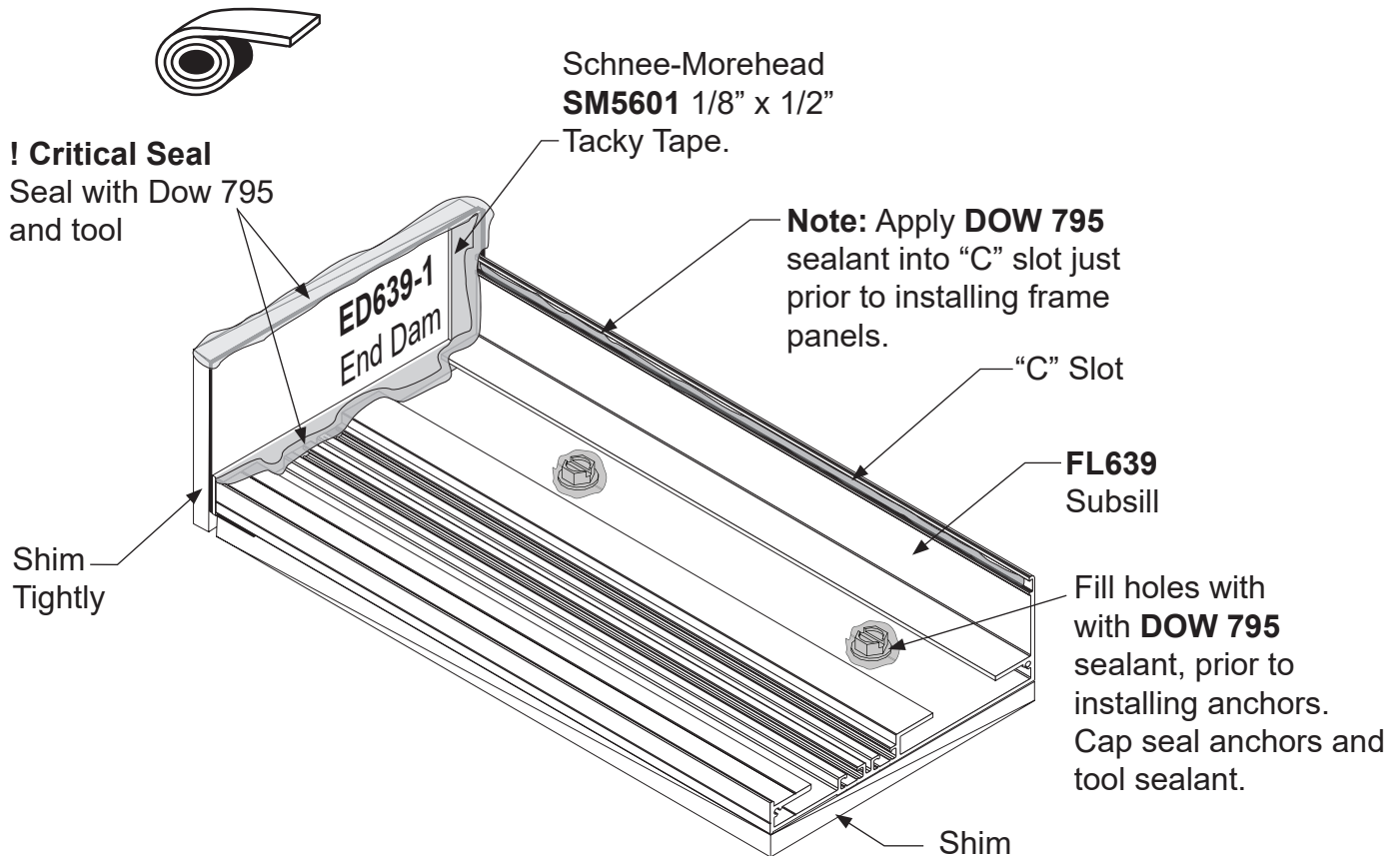

Shim beneath subsill to be a minimum of 1/4". Attach subsill flashing to structure with structural fasteners using attachment holes shown on **Page 13**. Cap seal fastener heads as shown.

Wedge shims tightly between end dams and jamb substrate on each end prior to installing frame panels. These shims prevent the end dam from dislodging while frame panels are being installed. Completely seal end dams to subsill and substrate as shown.

Run a continuous bead of **DOW 795** sealant along the full length of the subsill "C" slot as shown above just prior to installing frame panels. Do not allow sealant to harden prior to installing frame panels. Remove excess sealant after panels are installed.

Note: Remove all debris from subsill to prevent clogging weep holes prior to installing panels.

FRAME INSTALLATION

STEP 2.

Screw spline joinery allows for frames to be shop fabricated into panels and shipped to job site assembled. Each panel must have at least one vertical deep pocket for glazing. Arrange panels so that two shallow pockets never face each other. **Reference Page 16 (FRAME ASSEMBLY).**

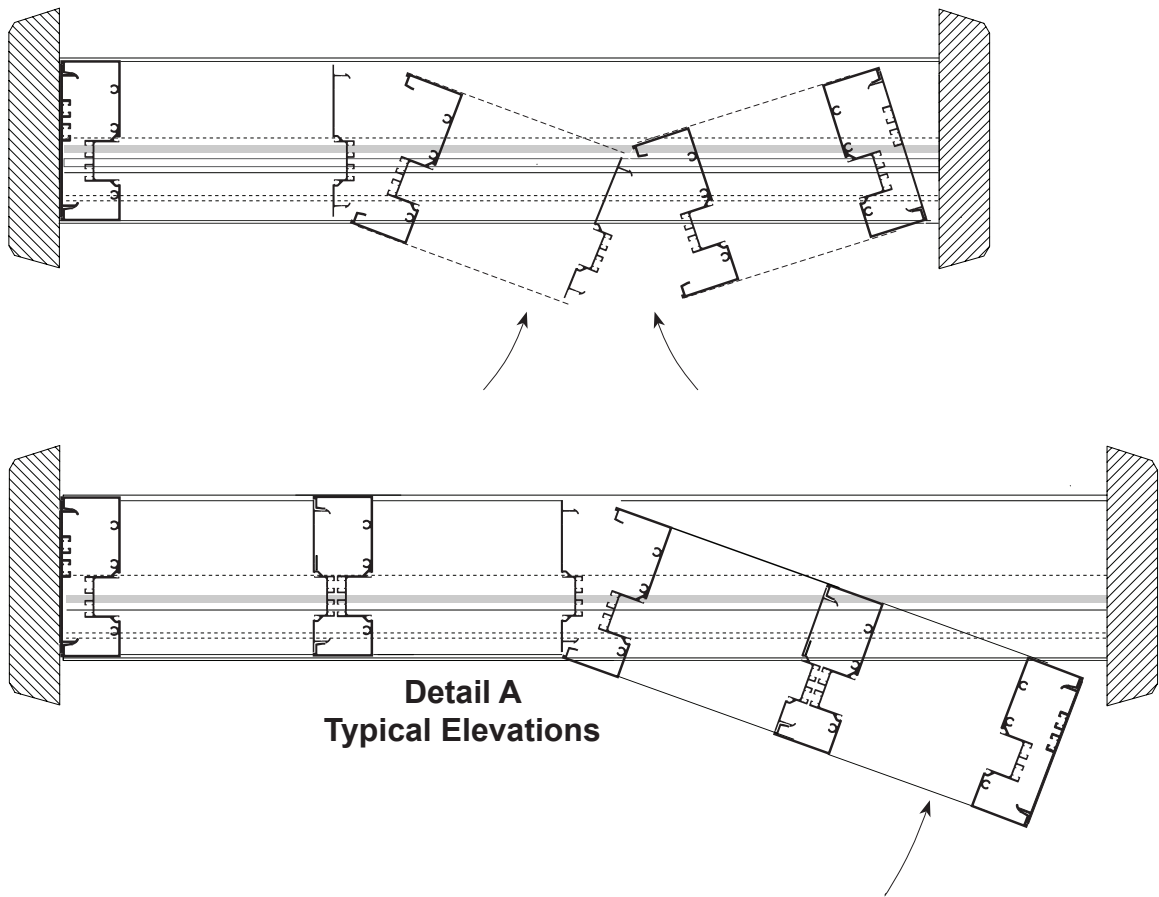

Note: Make sure the back leg of FL539 has sealant applied prior to setting panels. Once panels are installed and anchored, tool exposed sealant and clean off excess

FRAME INSTALLATION

STEP 3.

After all panels are installed and frame panels are attached to substrate at head, then attach sill to subsill with **AS56** per anchor charts (page 35) on each side vertical mullions in locations shown below.

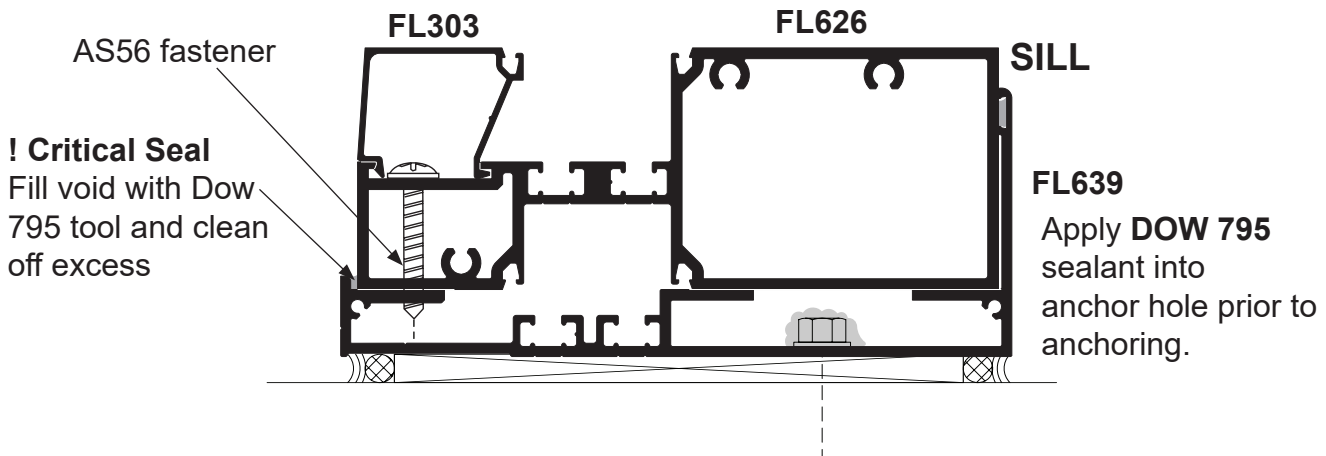
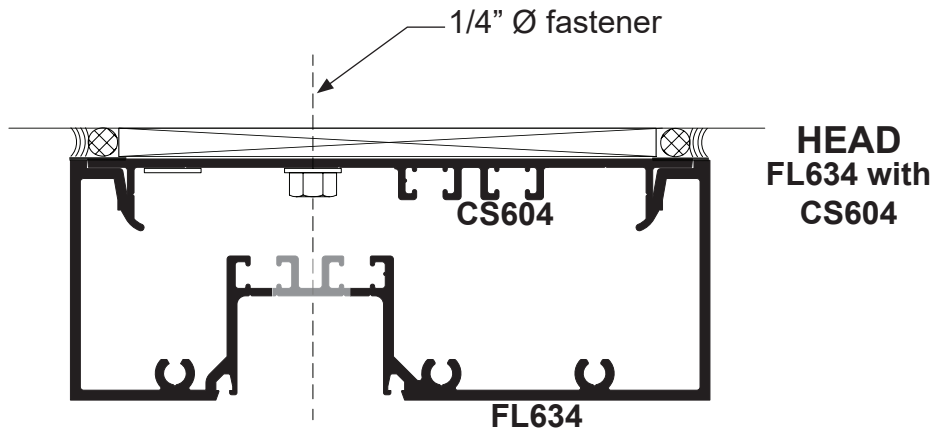
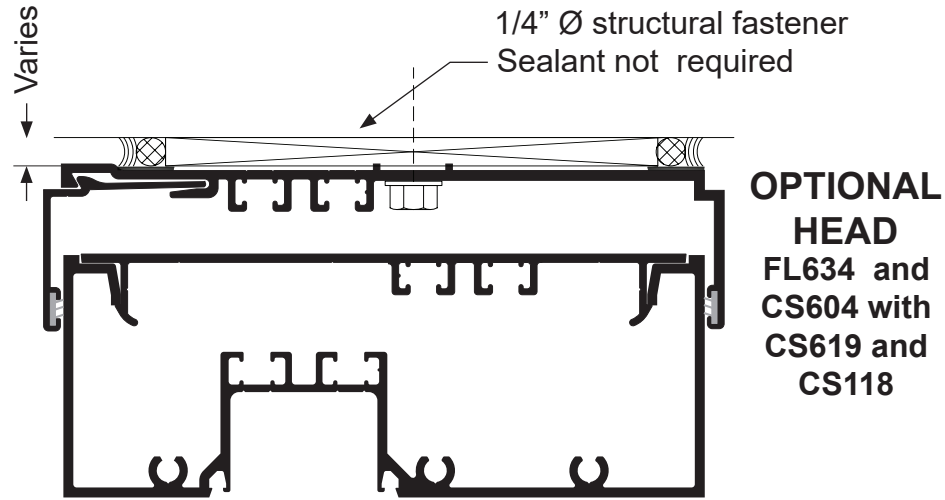

FRAME INSTALLATION

STEP 4.

In high wind zone areas and/or tall spans, it may be necessary to attach jamb to substrate as shown to limit deflection. When required, match drill holes in jamb to substrate. Anchor and shim as required. Cap seal fastener heads with **DOW 795** sealant.

When all frames are secured to the opening, then completely seal the exterior and interior perimeter with a continuous bead of Dow 795 sealant. Completely seal the space between the FL636 to the FL639 as shown below

1. All sealants to be **DOW 795**.

Completely Seal
Exterior & Interior
Perimeter of Frame

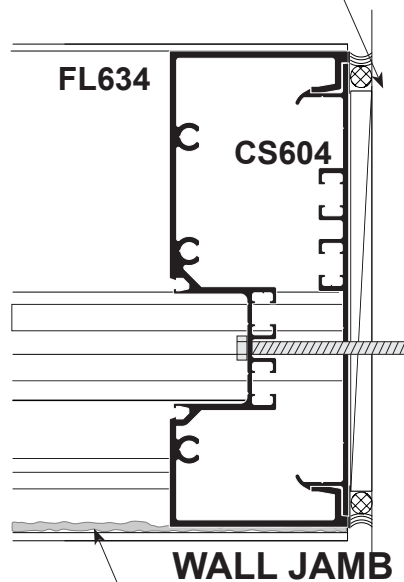

Completely seal
cavity at FL639 with **DOW 795**

GLASS SIZE FORMULAS

Glass Sizes for **FL600** System:

Glass Width and Height = D.L.O. + 7/8"

FL600 Door Frames with surface mounted closers
Transom parts FL607 Transom bar and FL634 Header
Width: door opening width - 1 1/8"
Height: daylite opening + 7/8"

FL600 Door Frames with concealed closers
Transom parts FL612 Transom bar and FL634 Header
Width: door opening width - 1 1/8" (CS115/FL518 will be on both vertical sides)
Height: daylite opening (taken from top of sash CS115 to bottom of FL634) - 1/8"

Note: Glass tolerances are not addressed in the above formula.
Consult glass manufacturer for glass tolerances prior to ordering.

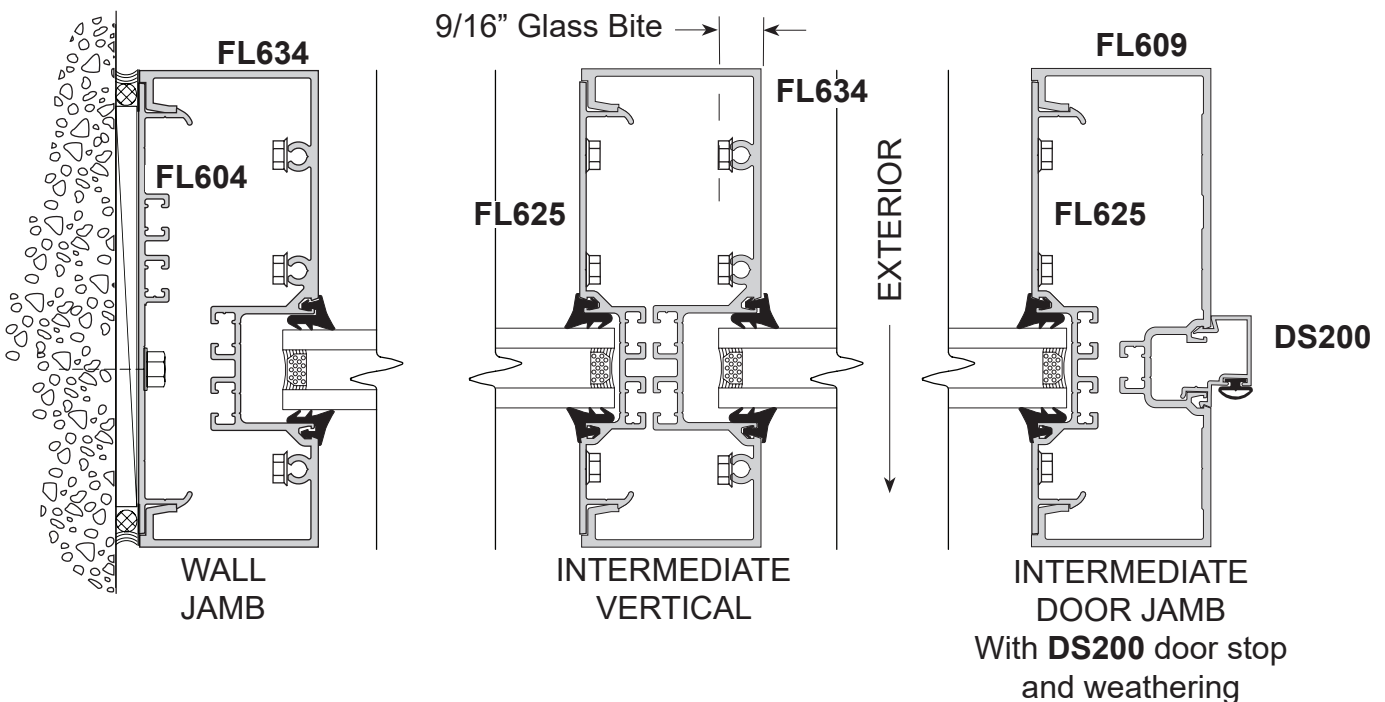

PREPARATION OF FRAME OPENING FOR GLASS

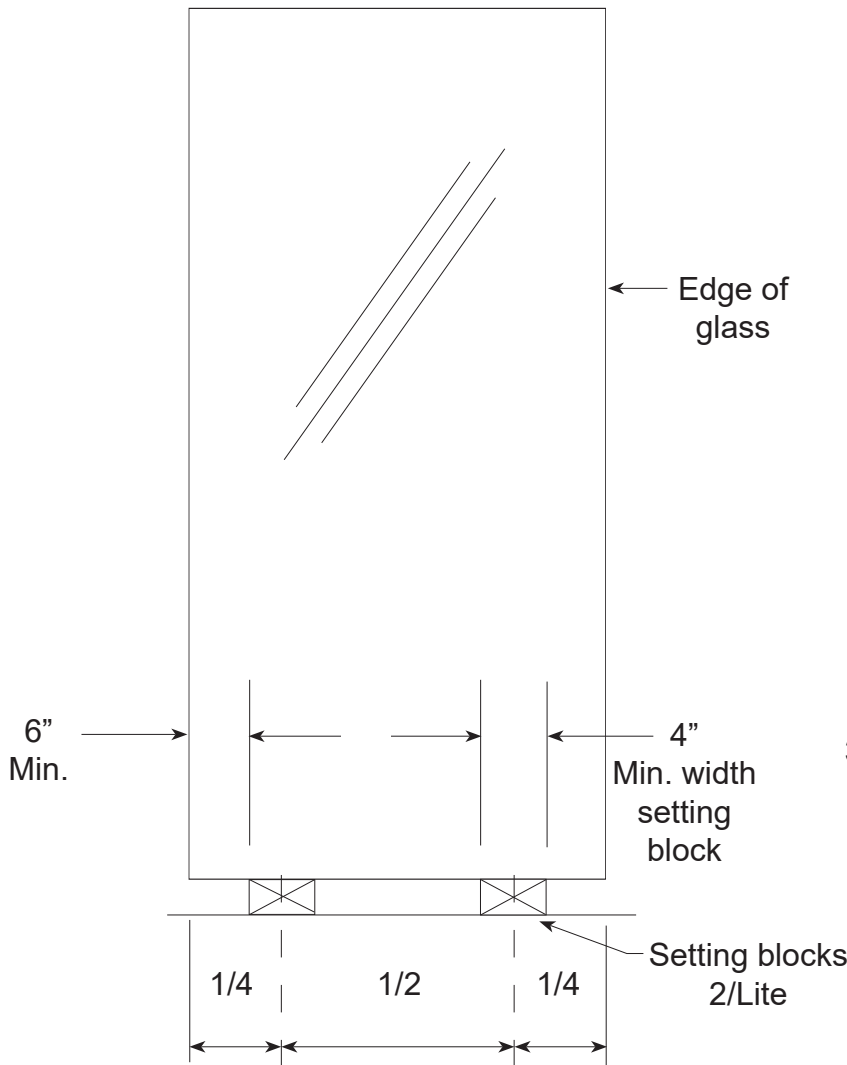

1. Prepare the frame opening by removing all dirt and debris from the glazing pockets and gasket reglets.

2. SETTING BLOCKS

Glass should be set on two identical setting blocks having a Shore A Durometer of 85 + or -5. The preferred location is at the 1/4 points.

If the 1/4 point location causes excessive deflection of the intermediate horizontal, move the setting blocks equally towards the corners of the lite as far as the 1/8 points. The outer end of the block **CANNOT** be closer than 6" to the corner of the glass.

3. DEFLECTION

The intermediate horizontal must not exceed 1/8" and a door header is limited to 1/16". Check dead load charts for proper setting block locations.

EXTERIOR GLAZING

GLASS SIZES*

GLASS SIZE = DAYLIGHT OPENING + 7/8"

Consult glass manufacturer for glass tolerance before ordering glass.

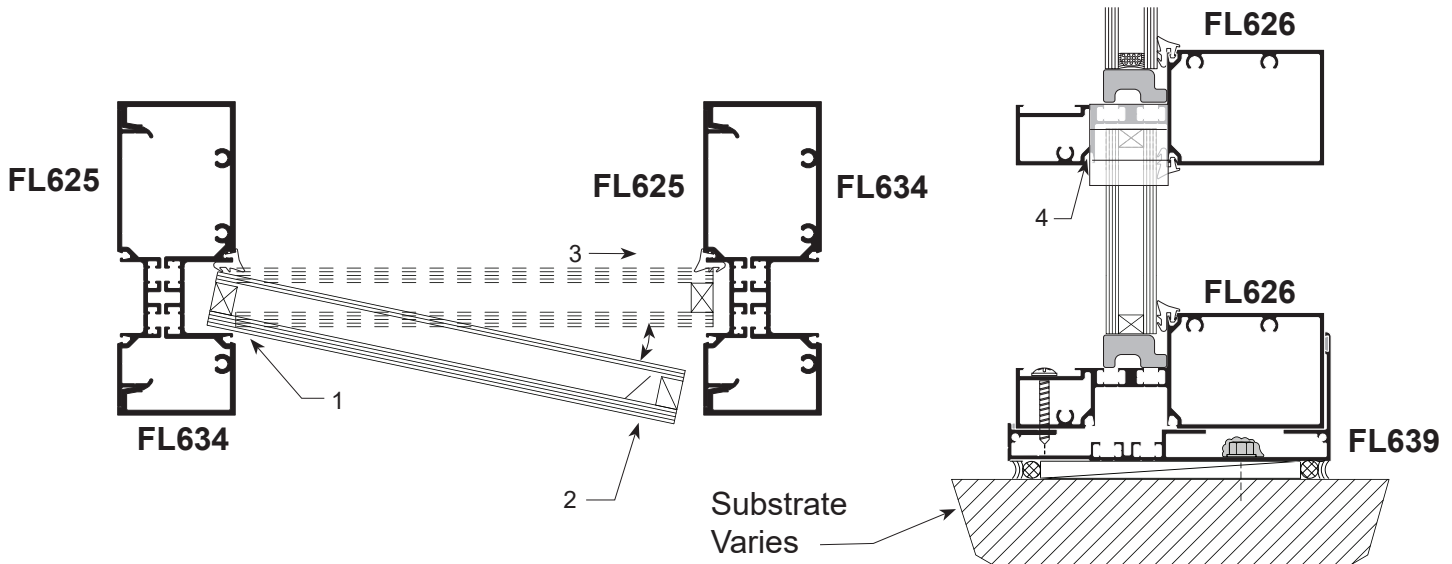

1. Install interior gasket. Vertical gasket runs through. **Reference Pages 28.**
2. Set glass in place following the four step procedure shown above. Center glass in the opening, making sure proper glass penetration is achieved. Rest glass on setting blocks.
3. Press glass against installed gaskets and snap-in **FL303** Glass Stop as shown below.
4. Install **NG1** exterior gaskets as shown on **Page 28.**

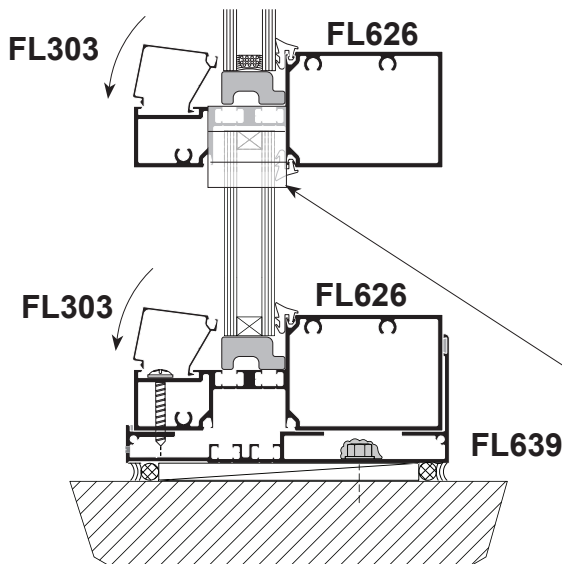

Detail

Glaze from bottom to top. Install **WD300-1** Water Diverter as shown before setting upper lite.

WD300-1 Water Diverter is embedded in sealant at each end of horizontal. Tool sealant completely

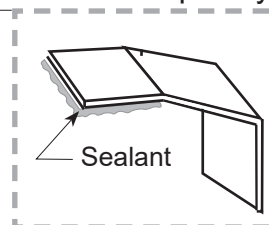

INSTALLATION OF TOP LOAD GLAZING GASKETS

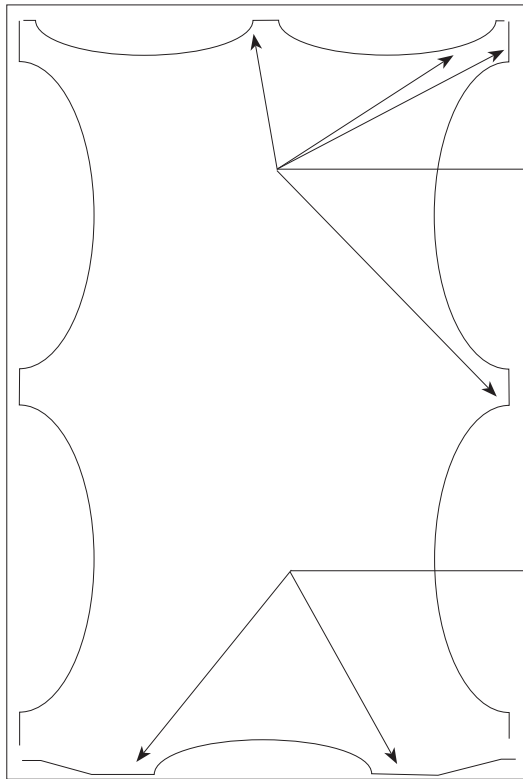

Detail A

Start jamb and head gaskets at corners and center.

Start gaskets at setting blocks



NG1 glazing gasket
shown actual size.

1. Cut gaskets a minimum of 3/16" longer per foot than aluminum extrusion.

2. Do not stretch gasket to make them fit.

It is very important that gaskets are installed correctly as shown in **Detail "A"**, to prevent shrinkage at corners.

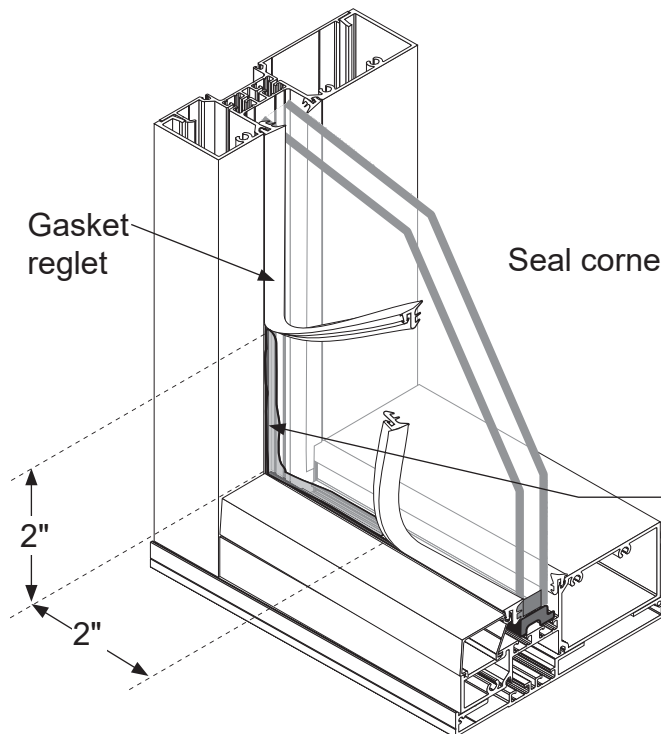

3. Pull gaskets back 2" in both directions at corner intersections & seal with **DOW 795** silicone sealant. This should be done on interior & exterior for best performance.

DOOR PREPARATION AND GLAZING

Door glass stops and gaskets are shipped loose.

SB1

Side Block
& Setting Block

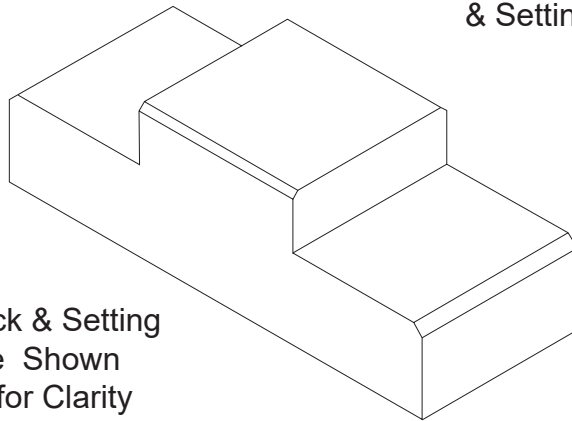

Side Block & Setting
Block are Shown
Inverted for Clarity

For 1" Glass (Rotate 90°
From 1/4" Position)

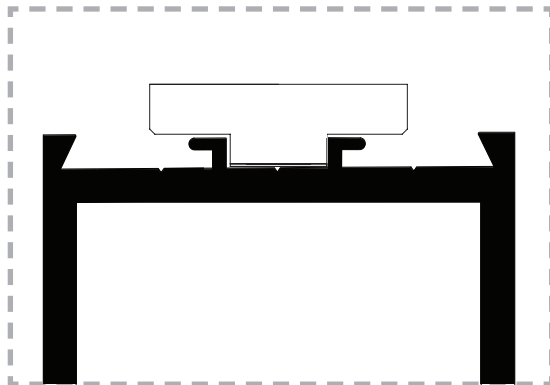

For 1/4" Glass

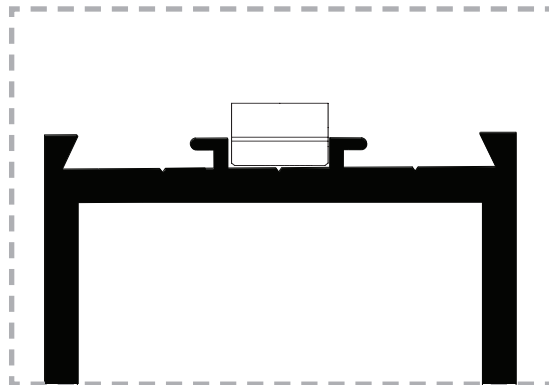

DOOR PREPARATION AND GLAZING

1. Install **DG100-1** glass stops on interior side of door.
2. Center glass in opening on setting blocks and align with side blocks.
3. Once the glass is in the correct position, lightly screw the glass adjustment screw down with **SP101** plastic tip attached to the top of the glass.
4. Install horizontal door glass stops.
5. Square door using adjustment screw located in top rail of door as required.

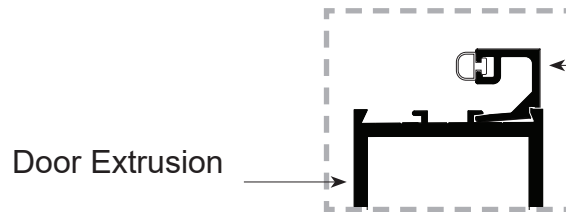

DG100-1 Glass Stop with bulb gasket

Use **DG101-1** Glass Stop for 1" insulating glass.

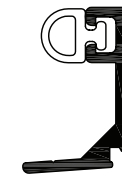
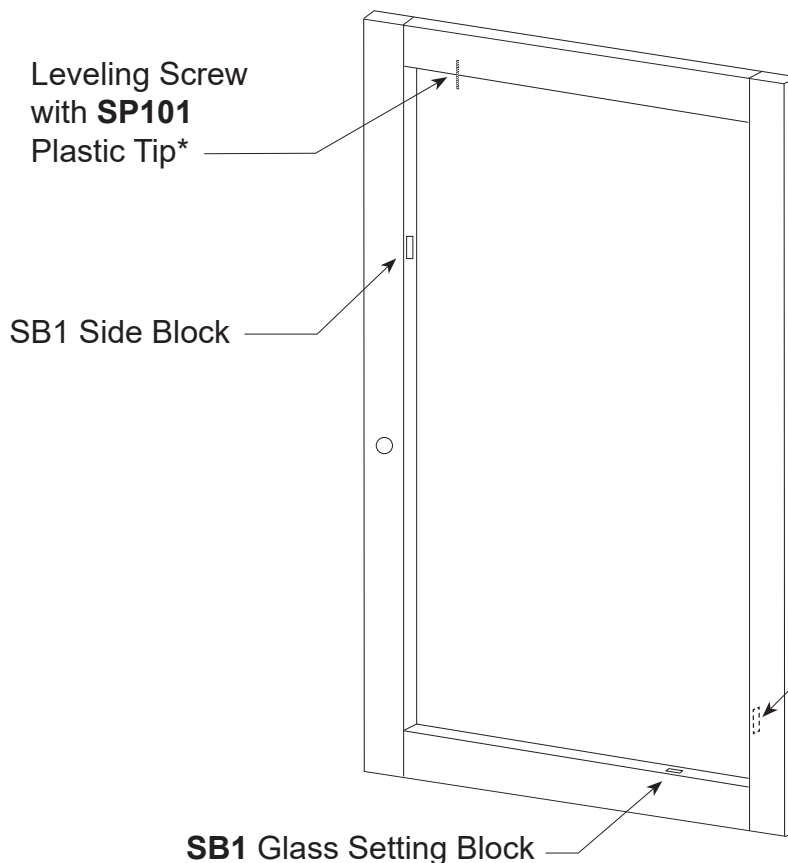

DG101-1

SB1 Side Block

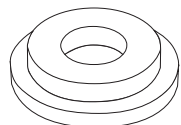

SP102

* If 1" glass is being glazed into door, install **SP102** plastic tip over **SP101**

SPECIAL CONDITIONS SPLICE AT HEAD EXPANDER

A minimum 3/8" expansion joint is required every 24 ft. Reference formula on Page 33.

Apply bond breaker tape to CS619 and splice sleeve full length of joint and seal over it.

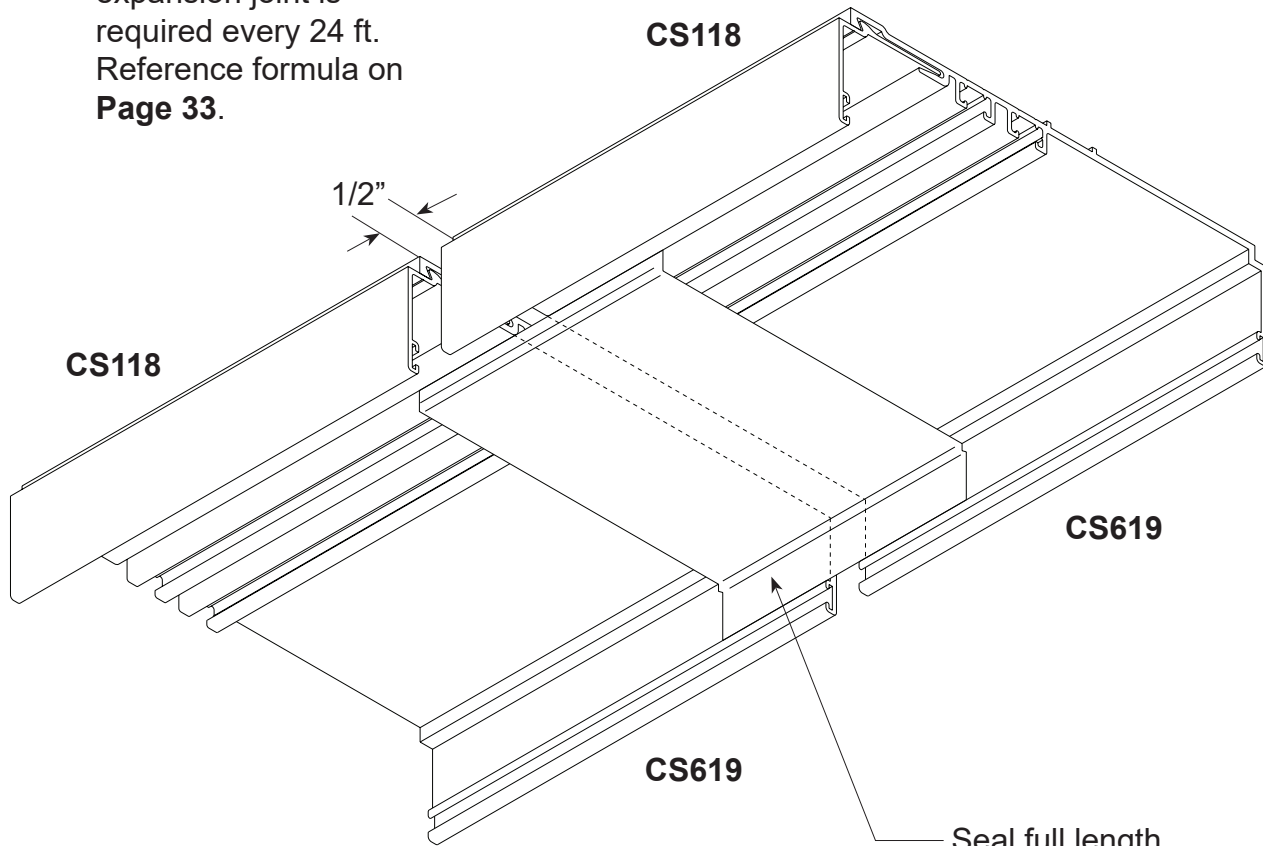

Seal full length of splice. To avoid a three side adhesion, apply bond breaker tape to outside of sleeve before installation.

SPECIAL CONDITIONS SPlice SLEEVE AT SUBSILL

STEP 1. Locate splice sleeves near center of D.L.O. at panel positioned over splice.

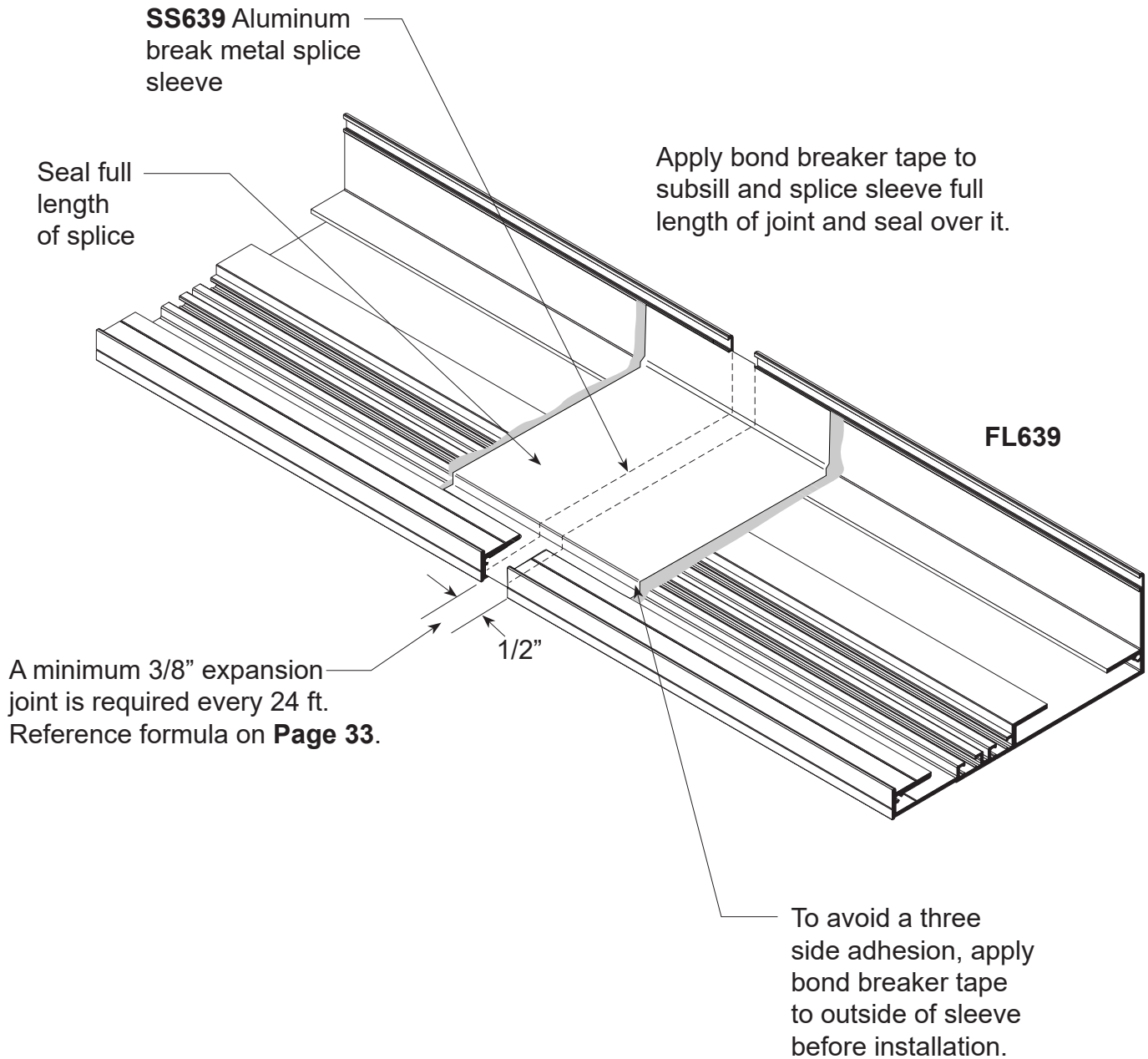

SPECIAL CONDITIONS EXPANSION MULLIONS

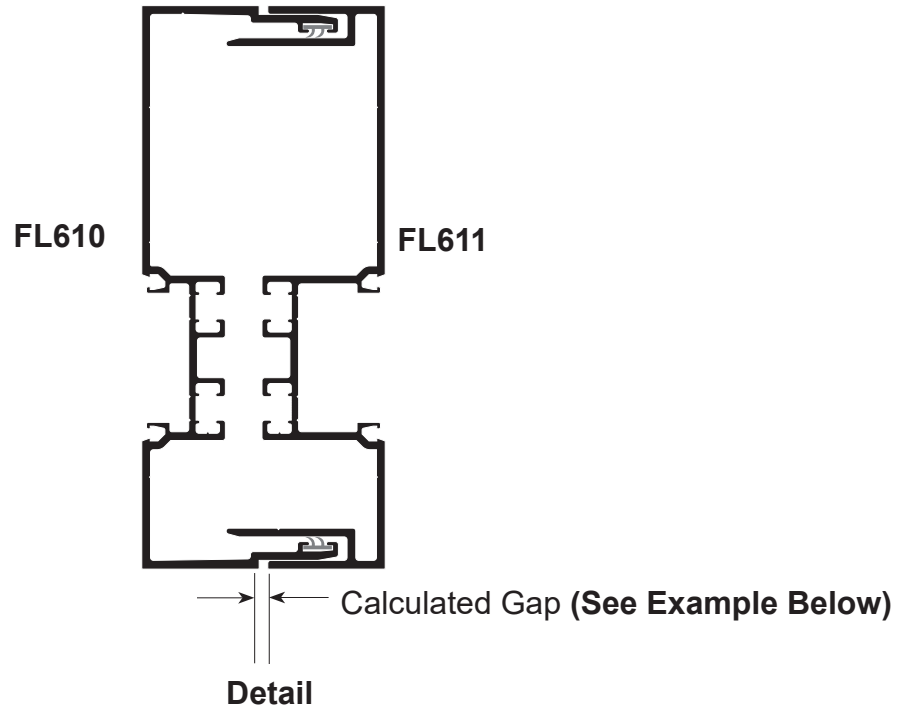

Calculated gap is determined by job conditions project specifications and temperature at the time of installation. Expansions mullions allow for 3/8" maximum movement.

EXPANSION GAP SIZE FORMULA= Length (") x F° difference x .0000129

L = Length in inches, between center line of expansion mullion in elevation.

F° = Specified Temperature Variation

.0000129 = Thermal Coefficient for Aluminum

FOR EXAMPLE:

Assume 100° temperature variation specified and temperature at job site on day of installation is 60°

1. $100^{\circ} - 60^{\circ} = 40^{\circ}$ temperature difference
2. Length of elevation between expansion mullions equals 20'- 0" or 240"
3. $240" \times .0000129 \times 40^{\circ} = .124"$ Therefore, set expansion mullion gap at .124" or 1/8".

SPECIAL CONDITIONS TRANSITION GLAZING

Adaptor

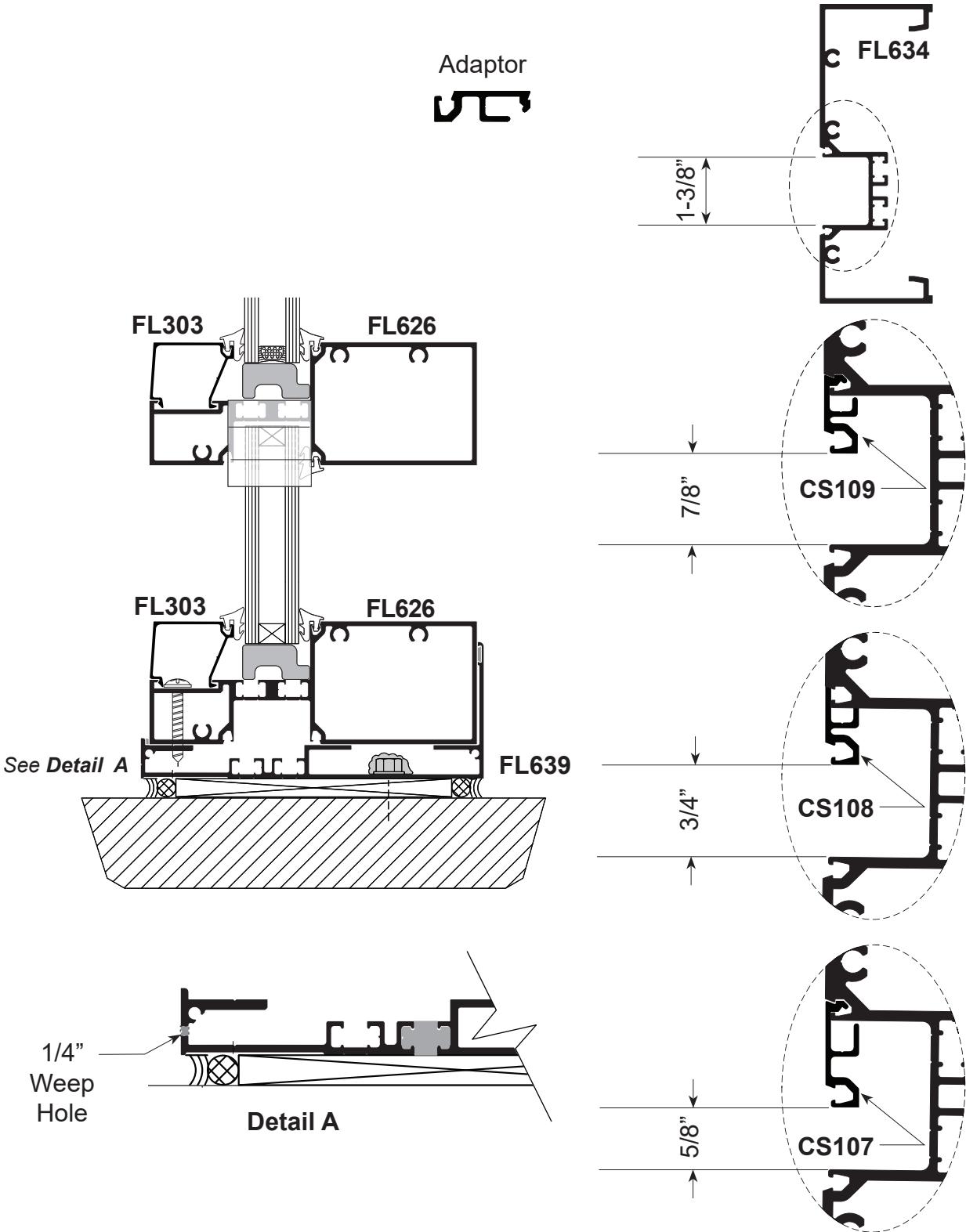

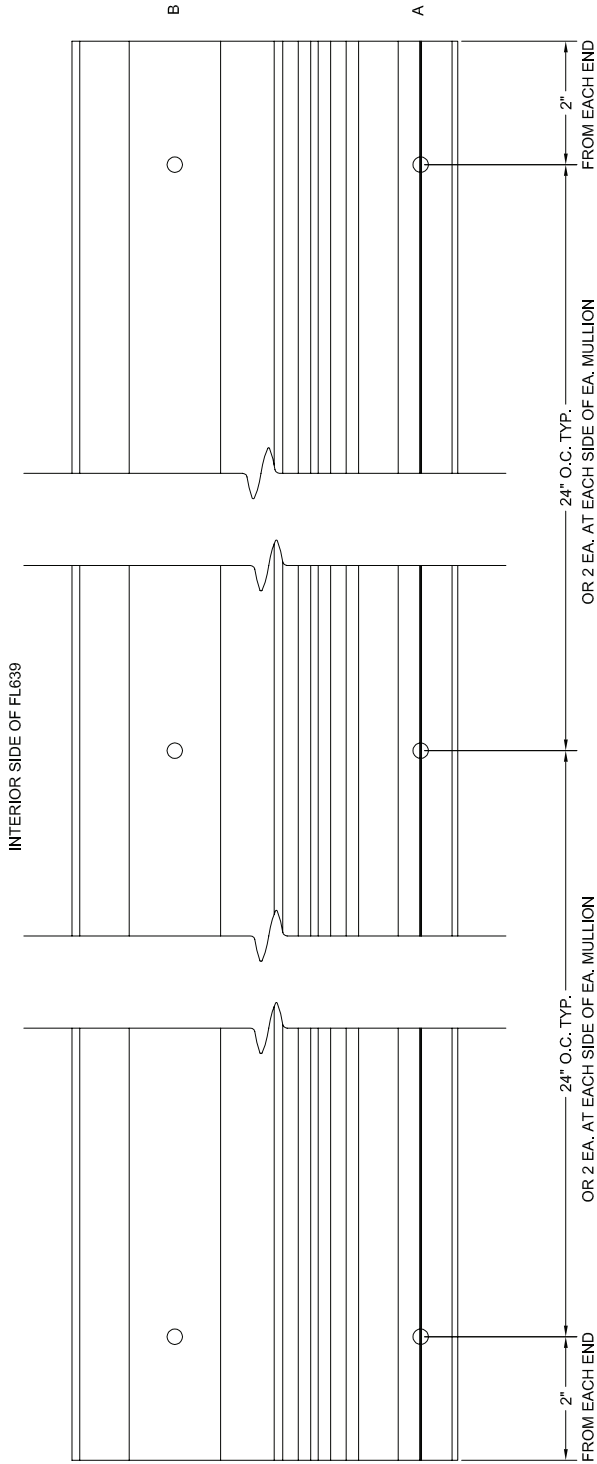

REFERENCE CHART BELOW FOR ANCHOR LOCATIONS

SUBSILL ANCHORING

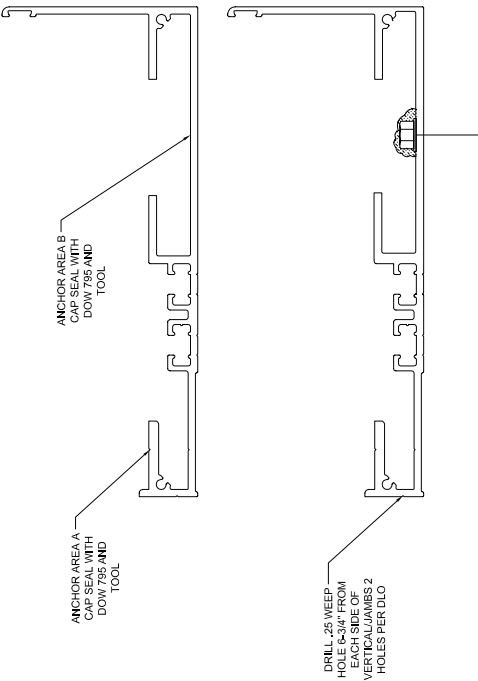

FL639 AND FL639T ANCHOR TYPES		
SUBSTRATE	ANCHOR TYPE	LENGTH BASED ON 1/2" SHIM SPACE
WOOD 1-1/2" THICK	#14 WOOD SCREW	1-3/4" EVERY 16" ON CENTER AND 2" FROM EACH END
WOOD 3" THICK	#14 WOOD SCREW	2-1/2" PER DRAWING ABOVE
CONCRETE MIN 2500 PSI	1/4" HEX HEAD TAPCON OR EQUAL	3" PER DRAWING ABOVE
STEEL STUD MIN 18 GA	#14 PH OR HH TEK SCREW	2" PER DRAWING ABOVE
STEEL HOT ROLLED MIN 1/8"	#14 PH OR HH TEK SCREW	2" PER DRAWING ABOVE
STEEL HOT ROLLED MIN 1/8"	#14 PH OR HH TEK SCREW	2" PER DRAWING ABOVE
STEEL HOT ROLLED MIN 1/8"	1/4" TYPE F OR STANDARD SAE AND TAP	2" PER DRAWING ABOVE

NOTES:
TAPCON TYPE ANCHORS MUST HAVE 3" MINIMUM BETWEEN EACH ANCHOR AND 2 1/2" MIN EDGE DISTANCE
DOOR FRAMES WITH AND WITH OUT TRANSOM MUST BE ANCHORED AS SHOWN ON CHART ABOVE AND BELOW

- PERIMETER FASTENERS:
1. TYPICAL INSTALLATION INTO SUBSTRATES
A. 2500 PSI CONCRETE
B. STEEL, 18 GA. MIN.
C. HOT ROLLED STEEL, 1/8" MIN. THICKNESS
D. SO. PINE, GRADE NO. 2 OR BETTER
2. FIRST ANCHOR IS 2" FROM EDGE OF VERTICAL. EACH ADDITIONAL FASTENER IS AT REQUIRED MIN. SPACING.

ANCHOR LENGTHS SHOWN MINIMUM TO MEET MINIMUM EMBEDMENT

DOOR FRAME TYPE	10 TOTAL
1/4" X 2" PAN OR HEX HEAD TEK SCREW	
1/4" X 2" TYPE F BOLT OR STANDARD SAE BOLT AND TAP	
1/4" X 2" BOLT NUT AND WASHER	
FROM BOTTOM OF HEADER DOOR OPENINGS UP 96"	
1 EACH	8 - 1/2"
1 EACH	11 - 1/2"
FROM CENTER OF DOOR OPENING UP TO 96"	
1 EACH	1 - 1/2" ABOVE CTR LINE
1 EACH	1 - 1/2" BELOW CTR LINE
FROM BOTTOM OF FRAME UP	
1 EACH	11 - 1/2"
1 EACH	14 - 1/2"

DOOR FRAME WITHOUT SIDELIGHTS DUPLICATE ANCHORING ON BOTH JAMBS AS SHOWN

TYPE	THRESHOLD ANCHORS
SINGLE DOORS UP TO 48"	1/4" X 2-1/2" FHP TAPCON OR EQUAL WITH 1-3/4" MINIMUM EMBEDMENT
3 ANCHORS TOTAL	(1) EACH AT CENTER LINE OF DOOR JAMB (1) EACH AT CENTER LINE OF DOOR OPENING (1) EACH AT 4" FROM EACH JAMB
PAIRS UP TO 96"	(1) EACH AT CENTER LINE OF DOOR OPENING (1) EACH BETWEEN CENTER LINE AND 4" JAMB ANCHORS
5 ANCHORS TOTAL	(1) EACH BETWEEN CENTER LINE AND 4" JAMB ANCHORS

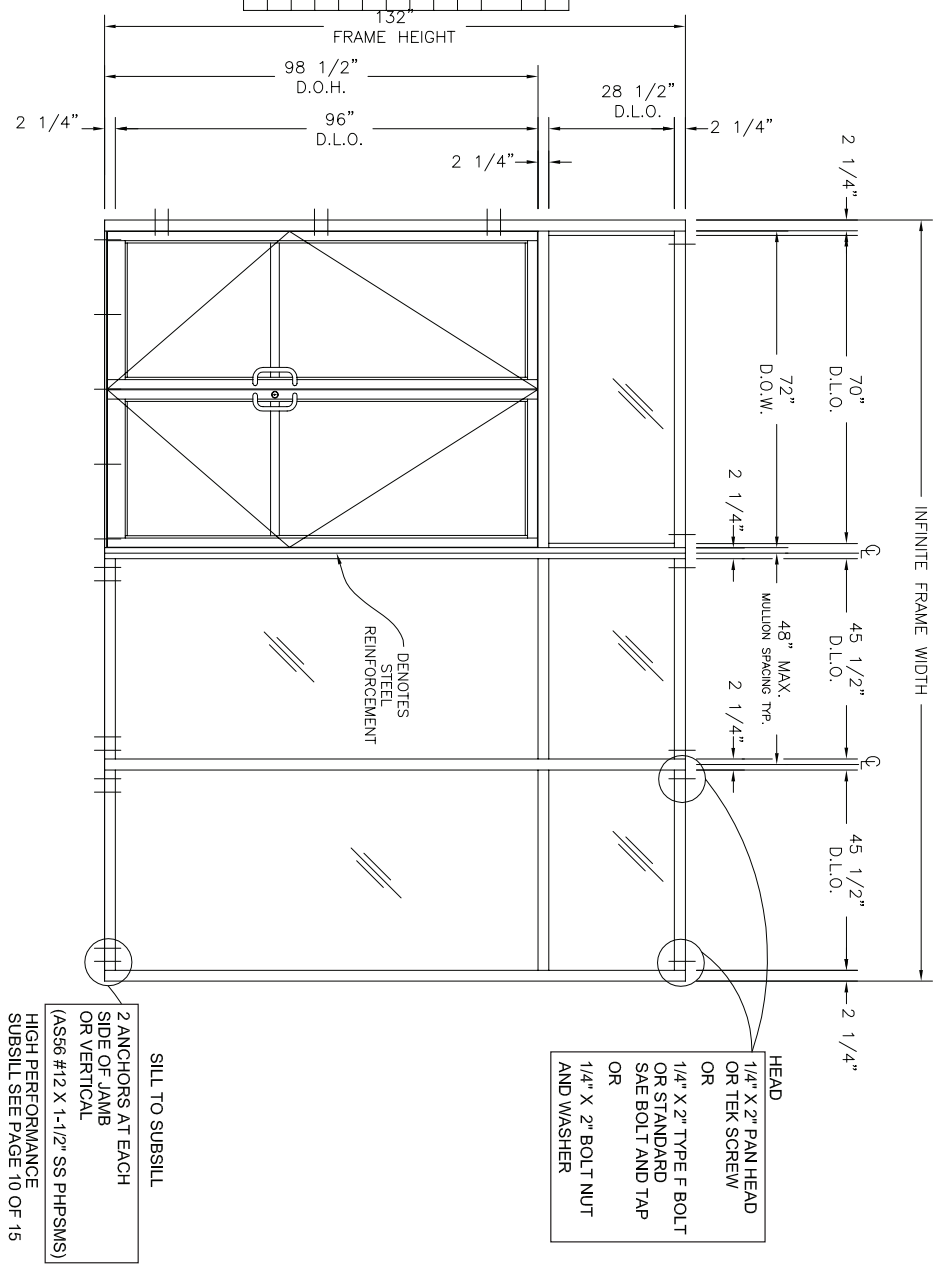

**STEEL SUBSTRATE
ANCHOR LOCATIONS**

NOTES:
TAPCON TYPE ANCHORS MUST HAVE 3" MINIMUM BETWEEN EACH ANCHOR AND 2 1/2" MIN EDGE DISTANCE
DOOR FRAMES WITH AND WITH OUT TRANSOM MUST BE ANCHORED AS SHOWN ON CHART ABOVE AND BELOW

PERIMETER FASTENERS:

1. TYPICAL INSTALLATION INTO SUBSTRATES
 - A. 2500 PSI CONCRETE
 - B. STEEL, 18 GA. MIN.
 - C. HOT ROLLED STEEL, 1/8" MIN. THICKNESS
 - D. SO. PINE, GRADE NO. 2 OR BETTER
2. FIRST ANCHOR IS 2" FROM EDGE OF VERTICAL. EACH ADDITIONAL FASTENER IS AT REQUIRED MIN. SPACING.

ANCHOR LENGTHS SHOWN MINIMUM TO MEET MINIMUM EMBEDMENT

DOOR FRAME TYPE	10 TOTAL
1/4" X 2" PAN OR HEX HEAD TEK SCREW	
FROM BOTTOM OF HEADER DOOR OPENINGS UP 96"	
1 EACH	8 - 1/2"
1 EACH	11 - 1/2"
FROM CENTER OF DOOR OPENING UP TO 96"	
1 EACH	1 - 1/2" ABOVE CTR LINE
1 EACH	1 - 1/2" BELOW CTR LINE
FROM BOTTOM OF FRAME UP	
1 EACH	11 - 1/2"
1 EACH	14 - 1/2"

DOOR FRAME WITHOUT SIDELIGHTS DUPLICATE ANCHORING ON BOTH JAMBS AS SHOWN

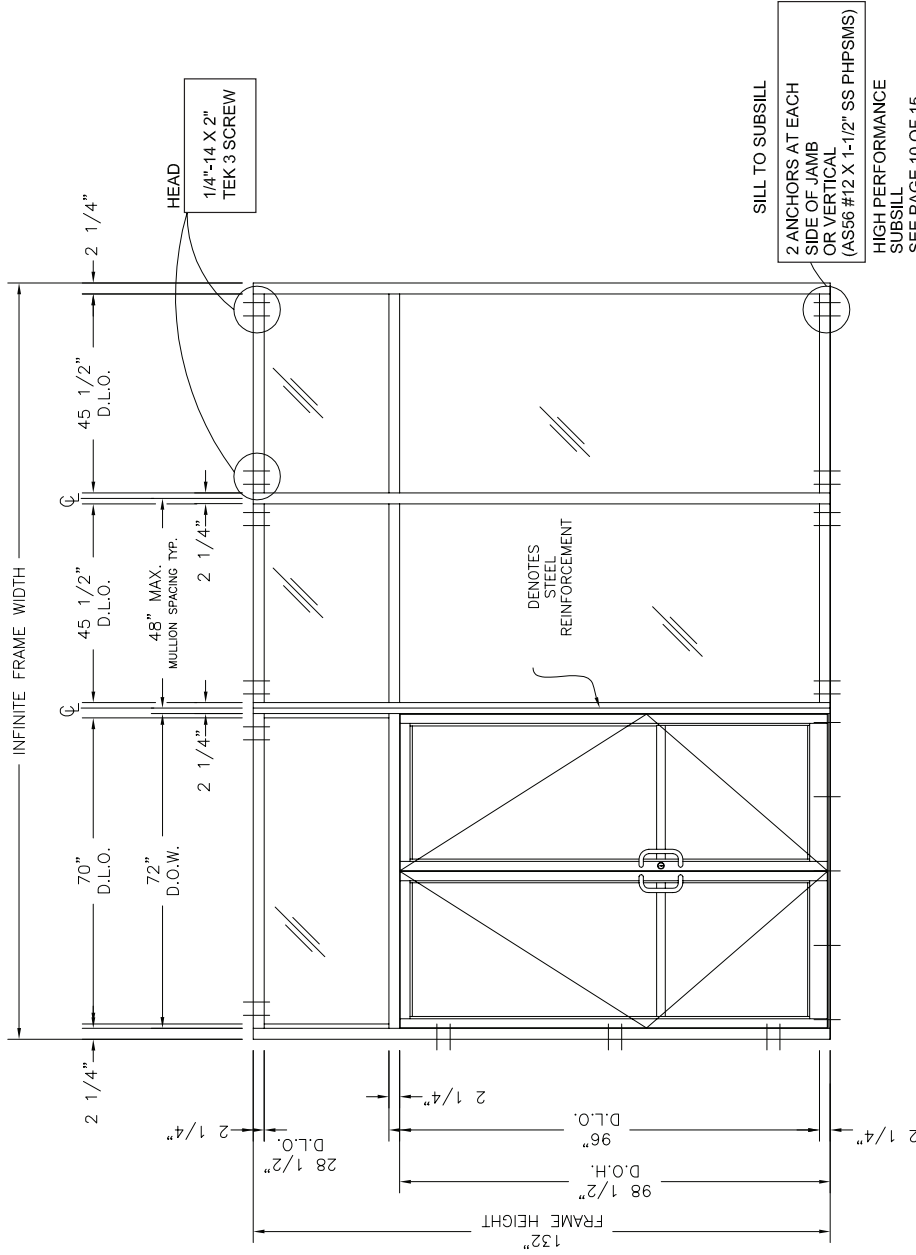

SILL TO SUBSILL
2 ANCHORS AT EACH SIDE OF JAMB OR VERTICAL (AS56 #12 X 1-1/2" SS PHPSMS)
HIGH PERFORMANCE SUBSILL
SEE PAGE 10 OF 15

**LIGHT GAUGE MIN. 18 GA. STEEL
OR MIN. 1/8" HOT ROLLED STEEL
SUBSTRATE ANCHOR LOCATIONS**

THRESHOLD ANCHORS	
TYPE	1/4" X 2-1/2" FHP TAPCON OR EQUAL WITH 1-3/4" MINIMUM EMBEDMENT
SINGLE DOORS UP TO 48"	(1) EACH 4" FROM EACH JAMB
3 ANCHORS TOTAL	(1) EACH AT CENTER LINE OF DOOR OPENING (1) EACH AT 4" FROM EACH JAMB
PAIRS UP TO 96"	(1) EACH AT CENTER LINE OF DOOR OPENING (1) EACH BETWEEN CENTER LINE AND 4" JAMB ANCHORS
5 ANCHORS TOTAL	

NOTES:
 PERIMETER FASTENERS:
 1. TYPICAL INSTALLATION INTO SUBSTRATES
 A. 2500 PSI CONCRETE
 B. STEEL, 18 GA. MIN.
 C. HOT ROLLED STEEL, 1/8" MIN. THICKNESS
 D. SO. PINE, GRADE NO. 2 OR BETTER
 2. FIRST ANCHORS 2" FROM EDGE OF VERTICAL. EACH ADDITIONAL FASTENER IS AT REQUIRED MIN. SPACING.
 ANCHOR LENGTHS SHOWN MINIMUM TO MEET MINIMUM EMBEDMENT

DOOR FRAME	10 TOTAL
TYPE	1/4" X 2-1/2" HEX TAPCON OR EQUAL
FROM BOTTOM OF HEADER DOOR OPENINGS UP 96"	
1 EACH	8 - 1/2"
1 EACH	11 - 1/2"
FROM CENTER OF DOOR OPENING UP TO 96"	
1 EACH	4 - 1/2" ABOVE CTR LINE
1 EACH	1 - 1/2" ABOVE CTR LINE
1 EACH	1 - 1/2" BELOW CTR LINE
1 EACH	4 - 1/2" BELOW CTR LINE
FROM BOTTOM OF FRAME UP	
1 EACH	11 - 1/2"
1 EACH	14 - 1/2"

DOOR FRAME WITHOUT SIDELIGHTS DUPLICATE ANCHORING ON BOTH JAMBS AS SHOWN

THRESHOLD ANCHORS	
TYPE	1/4" X 2-1/2" FHP TAPCON OR EQUAL WITH 1-3/4" MINIMUM EMBEDMENT
SINGLE DOORS UP TO 48"	(1) EACH 4" FROM EACH JAMB
3 ANCHORS TOTAL	(1) EACH AT CENTER LINE OF DOOR OPENING
	(1) EACH AT 4" FROM EACH JAMB
PAIRS UP TO 96"	(1) EACH AT CENTER LINE OF DOOR OPENING
5 ANCHORS TOTAL	(1) EACH BETWEEN CENTER LINE AND 4" JAMB ANCHORS

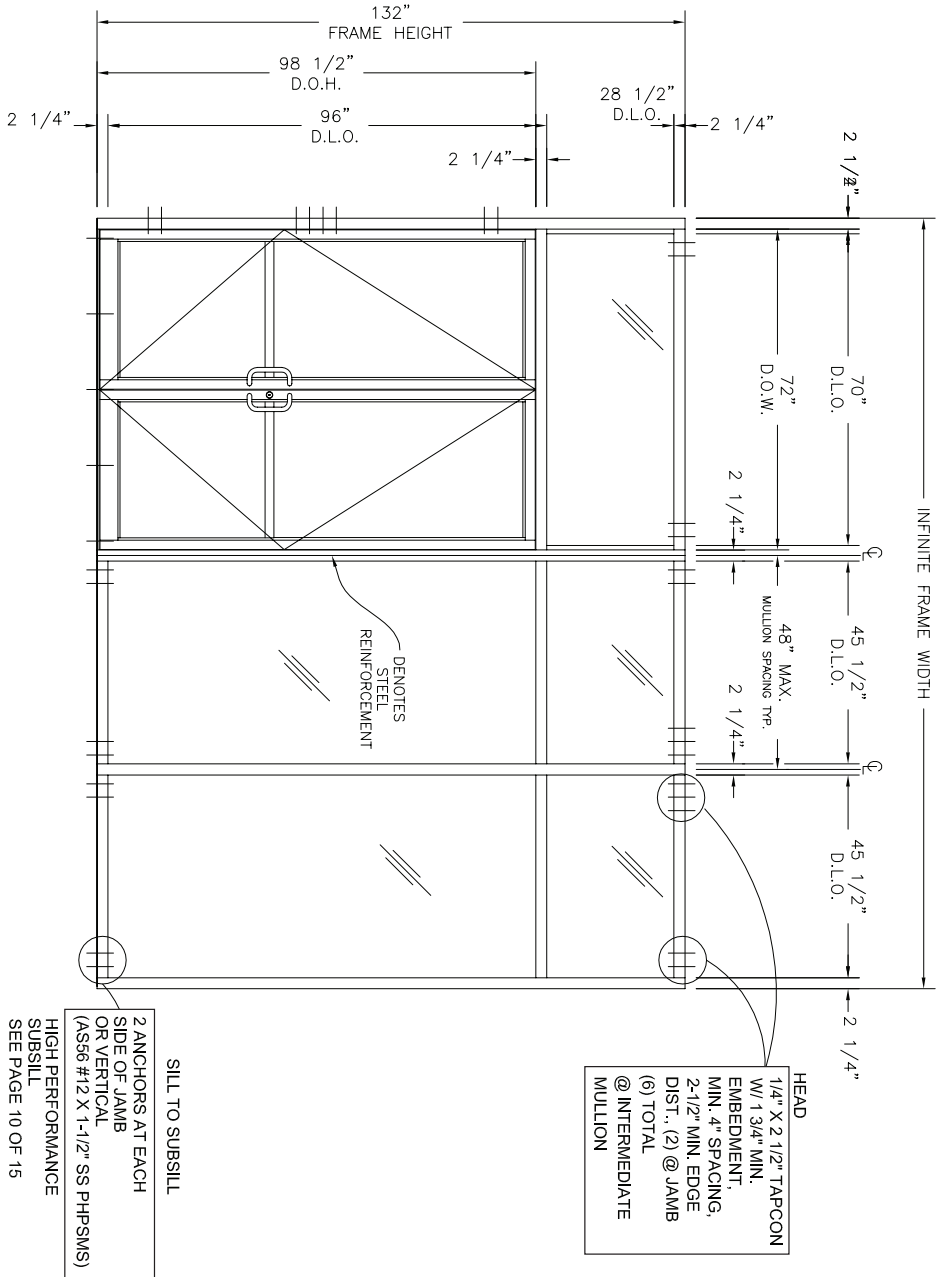

CONCRETE SUBSTRATE ANCHOR LOCATIONS

SILL TO SUBSILL
 2 ANCHORS AT EACH SIDE OF JAMB OR VERTICAL (ASS6 #12 X 1-1/2" SS PHPSMS)
 HIGH PERFORMANCE SUBSILL
 SEE PAGE 10 OF 15

NOTES:
 TAPCON TYPE ANCHORS MUST HAVE 3" MINIMUM BETWEEN EACH ANCHOR AND 2 1/2" MIN EDGE DISTANCE
 DOOR FRAMES WITH AND WITH OUT TRANSOM MUST BE ANCHORED AS SHOWN ON CHART ABOVE AND BELOW

PERIMETER FASTENERS:

- TYPICAL INSTALLATION INTO SUBSTRATES
 - 2500 PSI CONCRETE
 - STEEL, 18 GA. MIN.
 - HOT ROLLED STEEL, 1/8" MIN. THICKNESS
 - SO. PINE, GRADE NO. 2 OR BETTER
- FIRST ANCHOR IS 2" FROM EDGE OF VERTICAL. EACH ADDITIONAL FASTENER IS AT REQUIRED MIN. SPACING.

ANCHOR LENGTHS SHOWN MINIMUM TO MEET MINIMUM EMBEDMENT

DOOR FRAME TYPE	#14 X 3" PAN OR HEX HEAD WOOD SCREW	10 TOTAL
FROM BOTTOM OF HEADER DOOR OPENINGS UP 96"		
1 EACH	8 - 1/2"	
1 EACH	11 - 1/2"	
1 EACH	14 - 1/2"	
FROM CENTER OF DOOR OPENING UP TO 96"		
1 EACH	4 - 1/2" ABOVE CTR LINE	
1 EACH	1 - 1/2" ABOVE CTR LINE	
1 EACH	1 - 1/2" BELOW CTR LINE	
1 EACH	4 - 1/2" BELOW CTR LINE	
FROM BOTTOM OF FRAME UP		
1 EACH	11 - 1/2"	
1 EACH	14 - 1/2"	
1 EACH	17 - 1/2"	

DOOR FRAME WITHOUT SIDELIGHTS DUPLICATE ANCHORING ON BOTH JAMBS AS SHOWN

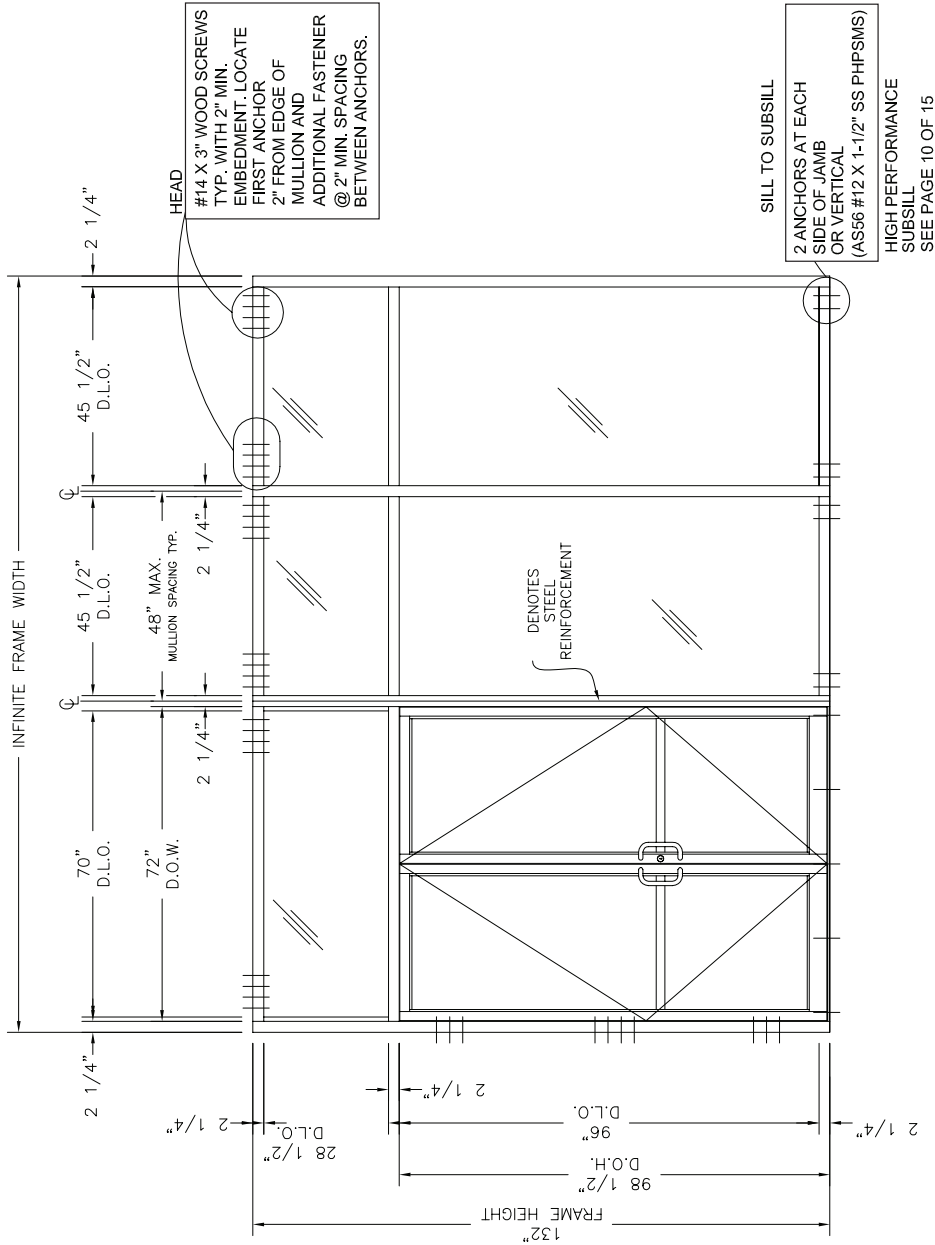

WOOD SUBSTRATE - 3" THICK ANCHOR LOCATIONS

THRESHOLD ANCHORS	
TYPE	1/4" X 2-1/2" FHP TAPCON OR EQUAL WITH 1-3/4" MINIMUM EMBEDMENT (1) EACH 4" FROM EACH JAMB
SINGLE DOORS UP TO 48"	
3 ANCHORS TOTAL	(1) EACH AT CENTER LINE OF DOOR OPENING (1) EACH AT 4" FROM EACH JAMB
PAIRS UP TO 96"	(1) EACH AT CENTER LINE OF DOOR OPENING
5 ANCHORS TOTAL	(1) EACH BETWEEN CENTER LINE AND 4" JAMB ANCHORS

NOTES:
 TAPCON TYPE ANCHORS MUST HAVE 3" MINIMUM BETWEEN EACH ANCHOR AND 2 1/2" MIN EDGE DISTANCE
 DOOR FRAMES WITH AND WITH OUT TRANSOM MUST BE ANCHORED AS SHOWN ON CHART ABOVE AND BELOW

PERIMETER FASTENERS:

1. TYPICAL INSTALLATION INTO SUBSTRATES
 - A. 2500 PSI CONCRETE
 - B. STEEL, 18 GA. MIN.
 - C. HOT ROLLED STEEL, 1/8" MIN. THICKNESS
 - D. SO. PINE, GRADE NO. 2 OR BETTER
2. FIRST ANCHOR IS 2" FROM EDGE OF VERTICAL. EACH ADDITIONAL FASTENER IS AT REQUIRED MIN. SPACING.

ANCHOR LENGTHS SHOWN MINIMUM TO MEET MINIMUM EMBEDMENT

DOOR FRAME TYPE	10" TOTAL
#14 X 2-3/4" PAN OR HEX HEAD WOOD SCREW	
FROM BOTTOM OF HEADER DOOR OPENINGS UP 96"	
1 EACH	8 - 1/2"
1 EACH	11 - 1/2"
1 EACH	14 - 1/2"
FROM CENTER OF DOOR OPENING UP TO 96"	
1 EACH	4 - 1/2" ABOVE CTR LINE
1 EACH	1 - 1/2" ABOVE CTR LINE
1 EACH	1 - 1/2" BELOW CTR LINE
1 EACH	4 - 1/2" BELOW CTR LINE
FROM BOTTOM OF FRAME UP	
1 EACH	11 - 1/2"
1 EACH	14 - 1/2"
1 EACH	17 - 1/2"

DOOR FRAME WITHOUT SIDELIGHTS DUPLICATE ANCHORING ON BOTH JAMBS AS SHOWN

TYPE	THRESHOLD ANCHORS
SINGLE DOORS UP TO 48"	1/4" X 2-1/2" FHP TAPCON OR EQUAL WITH 1-3/4" MINIMUM EMBEDMENT (1) EACH 4" FROM EACH JAMB
3 ANCHORS TOTAL	(1) EACH AT CENTER LINE OF DOOR OPENING (1) EACH AT 4" FROM EACH JAMB
PAIRS UP TO 96"	(1) EACH AT CENTER LINE OF DOOR OPENING (1) EACH BETWEEN CENTER LINE AND 4" JAMB ANCHORS
5 ANCHORS TOTAL	

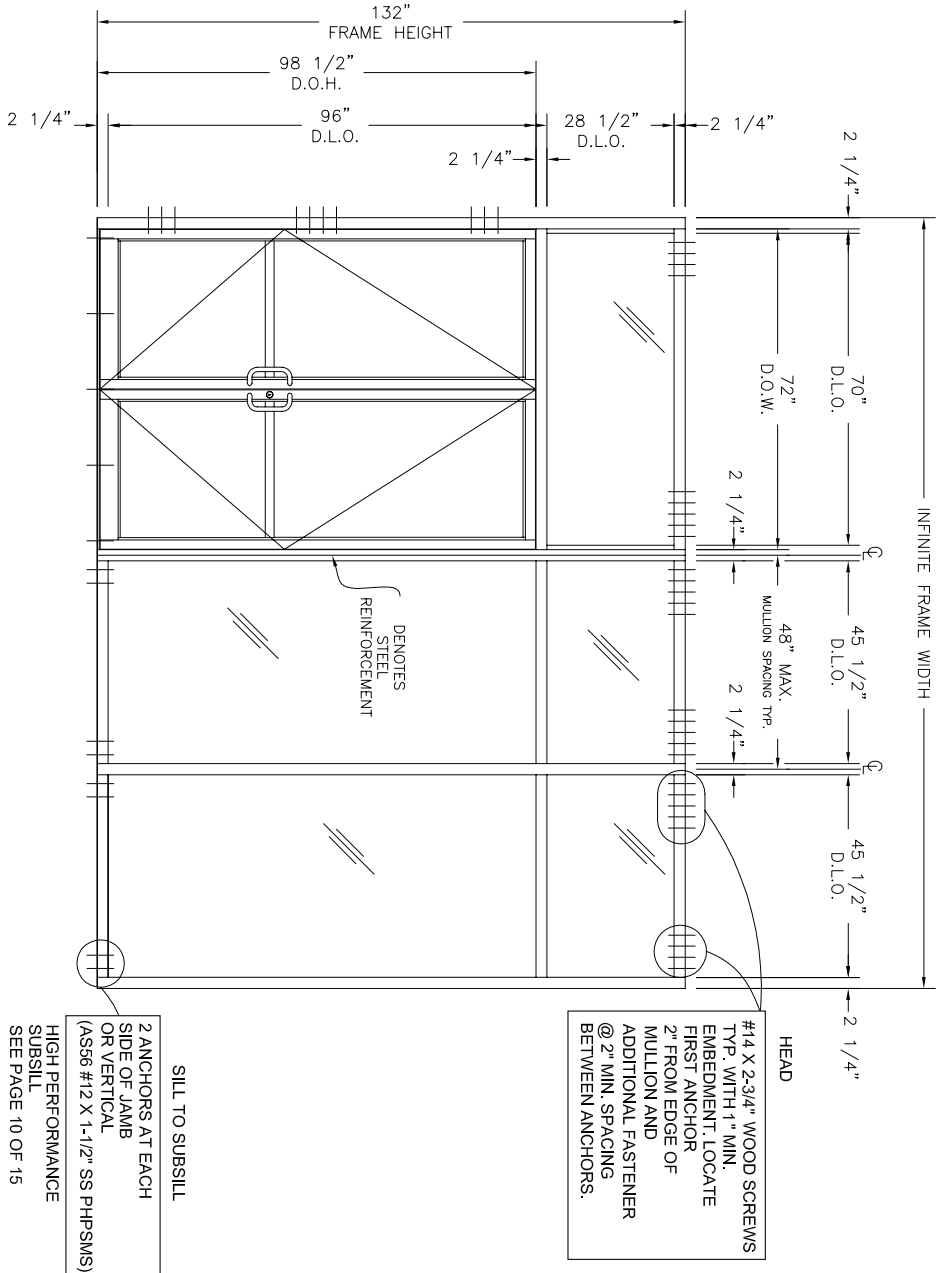

WOOD SUBSTRATE - 1-1/2" THICK ANCHOR LOCATIONS