

FL300

STOREFRONT SYSTEM

INSTALLATION INSTRUCTIONS

2" x 4 1/2" for 1" Glass

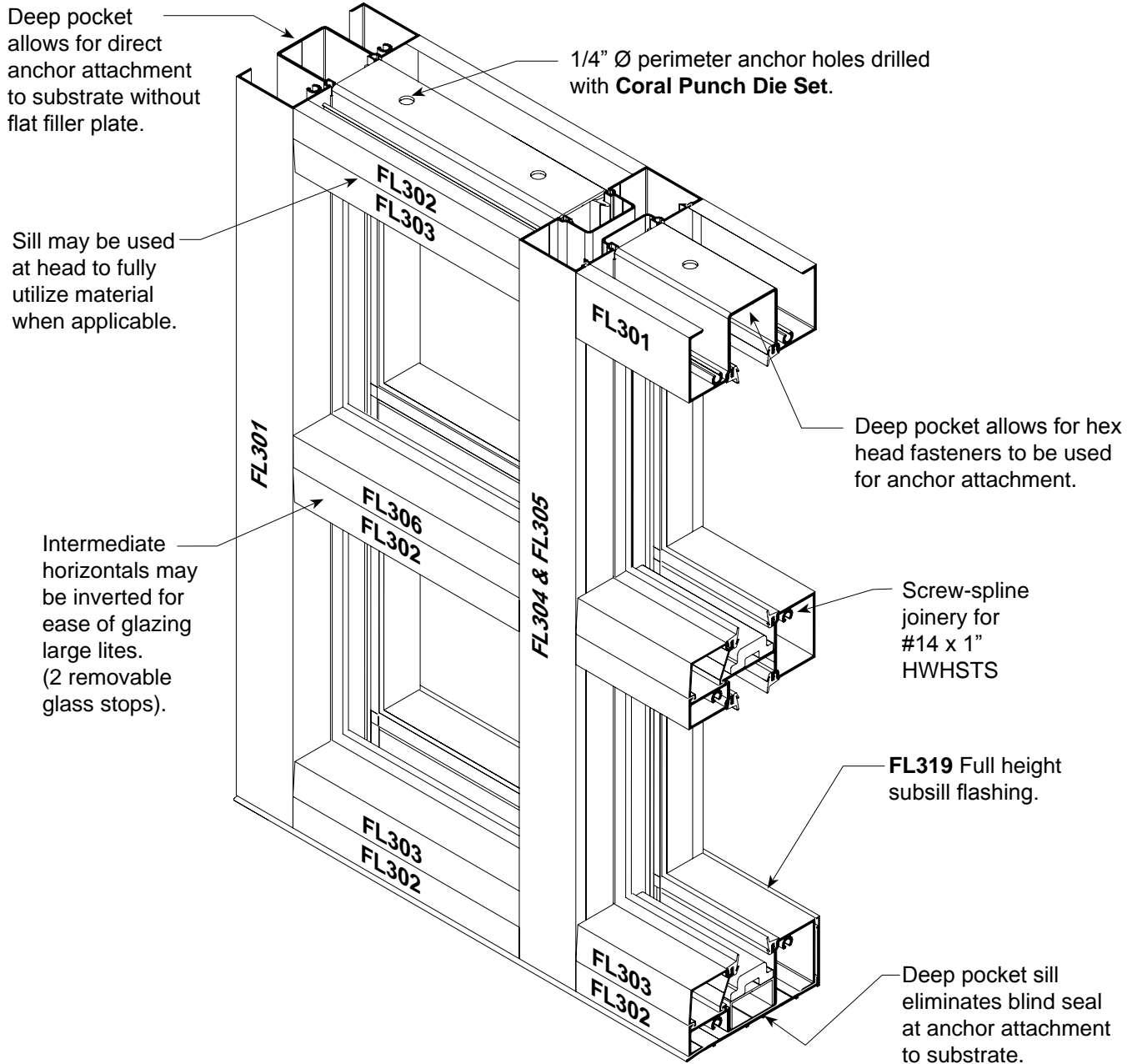

These instructions are for typical installations. Reference shop drawings for special notations on installations and glazing.

TABLE OF CONTENTS

	<i>Page</i>
General Installation Information.....	3-4
Frame Fabrication.....	5-11
Frame Assembly.....	12-14
Frame Installation.....	15-18
Glazing.....	19-22
Entrance Door Frame Installation.....	23
Preparation of Door Frame.....	24
Installation of Door Frame.....	25
Door Preparation and Glazing.....	26-27
Special Conditions.....	28-29
Transition Glazing.....	30
Expansion Mullions.....	31

INSTALLATION INSTRUCTIONS - General Notes -

RECOMMENDED GUIDELINES FOR ALL INSTALLATIONS:

- 1. REVIEW CONTRACT DOCUMENTS.** Check shop drawings, installation instructions, architectural drawings and shipping lists to become thoroughly familiar with the project. The shop drawings take precedence and include specific details for the project. Field verified notations shown within shop drawings must be resolved prior to installation. The installation instructions are of general nature and cover most conditions.
- 2. INSTALLATION.** All materials shall be installed plumb, level and true.
- 3. BENCHMARKS.** All work should start from established benchmarks and column center lines established by the architect and general contractor.
- 4. FIELD WELDING.** All field welding must be adequately shielded to avoid any splatter on glass or aluminum. Advise general contractor and other trades accordingly. All field welds of steel anchors must receive touch-up paint (zinc chromate) to avoid rust.
- 5. SURROUNDING CONDITIONS.** Make certain that construction which will receive your materials is in accordance with the contract documents. If not, notify the general contractor in writing and resolve differences before proceeding with work.
- 6. ISOLATION OF ALUMINUM.** Aluminum to be placed in direct contact with uncured masonry or incompatible materials should be isolated with a heavy coat of zinc chromate or bituminous paint.
- 7. SEALANTS.** Sealants must be compatible with all materials with which they have contact, including other sealant surfaces. Consult with sealant manufacturer for recommendations relative to joint size, shelf life, compatibility, cleaning, priming, tooling, adhesion, etc. It is the responsibility of the Glazing Contractor to submit a statement from the sealant manufacturer indicating that glass and glazing materials have been tested for compatibility and adhesion with glazing sealants, and interpreting test results relative to material performance, including recommendations for primers and substrate preparation required to obtain adhesion. The chemical compatibility of all glazing materials and framing sealants with each other and with like materials used in glass fabrication must be established.
- 8. FASTENING.** Only those fasteners used within the system are specified in these instructions. Due to the varying perimeter conditions and performance requirements perimeter fasteners are not specified in these instructions. Reference the shop drawings or anchor charts for perimeter fasteners.
- 9. BUILDING CODES.** Due to the diversity in state, local and national codes that govern the design and application of architectural products, it is the responsibility of the architect, owner and installer to assure that products selected for use on each project comply with all the applicable building codes and laws. CORAL ARCHITECTURAL PRODUCTS exercises no control over the use or application of its products, glazing materials and operating hardware and assumes no responsibility thereof.
- 10. EXPANSION JOINTS.** Expansion joints and perimeter seals shown in these instructions and shop drawings are shown at normal size. Expansion mullion gaps should be based on temperature at time of installation.

INSTALLATION INSTRUCTIONS

- General Notes -

- 11. WATER HOSE TEST.** After a representative amount of the storefront system has been glazed (500 square feet) and the sealant has cured, a water hose test should be conducted in accordance with AAMA 501.2 specifications to check the installation. This test should be repeated every 500 square feet during the glazing operation. Note: This test procedure should not be used for entrance doors.
- 12. COORDINATION WITH OTHER TRADES.** Coordinate with the general contractor and sequence with other trades items which offset the storefront installation such as back-up walls, partitions, ceilings and mechanical ducts.
- 13. MATERIAL HANDLING:**
- A. SHOP
 - 1. Cardboard wrapped or paper interleaved material must be kept dry.
 - 2. Immediately remove aluminum from cardboard wrapped or paper interleaved materials should it get wet to prevent staining or etching aluminum finish.
 - 3. Check arriving materials for quantity and keep record of where various materials are stored.
 - B. JOB SITE
 - 1. Material at job site must be stored in a safe place well removed from possible damage by other trades.
 - 2. Cardboard wrapped or paper interleaved material must be keep dry. (See 13.A.2)
 - 3. Keep record of where various materials are stored.
 - 4. Protect materials after erection. Cement, plaster, mortar and other alkaline solutions are very harmful to the finish.
- 14. CARE AND MAINTENANCE.** Final cleaning of exposed aluminum surfaces should be done in accordance with AAMA. 609.1 for anodized aluminum and 610.1 for painted aluminum.
- 15. CORAL ARCHITECTURAL PRODUCTS.** It is the responsibility of CORAL ARCHITECTURAL PRODUCTS to supply a system to meet the architect's specifications.

FRAME FABRICATION

Establish Frame Size and Cut Metal to Length

STEP 1.

Measure width of rough opening.

- A. Measure opening at bottom.
- B. Measure opening at center.
- C. Measure opening at top.

The frame width will be the smallest dimension less 1/2" allowing for a minimum 1/4" caulk joint at each jamb.

Repeat process to determine frame height.

- A. Beginning on left side of opening, measure dimension from top to bottom.
- B. Repeat at center.
- C. Repeat at right side of opening.

The frame height will be the smallest dimension less 5/8" allowing 1/8" for subsill and a 1/4" minimum caulk joint at the head and sill.

STEP 2.

Cut members to size.

- A. Cut subsill to frame dimension plus 1/4". The subsill at entrance locations butt tight against door jambs and is cut 1/8" longer than width of side lights on either side of door frame.
- B. Wall jambs and intermediate vertical mullions are cut to frame height.
- C. Horizontal members are cut to D.L.O.
- D. Snap-on glass stops are cut D.L.O. minus (-) 1/16".

FRAME FABRICATION

STEP 3.

Mark location for horizontals on vertical extrusions and drill holes for screw spline. Reference **STEP 4** for correct orientation of drill jig.

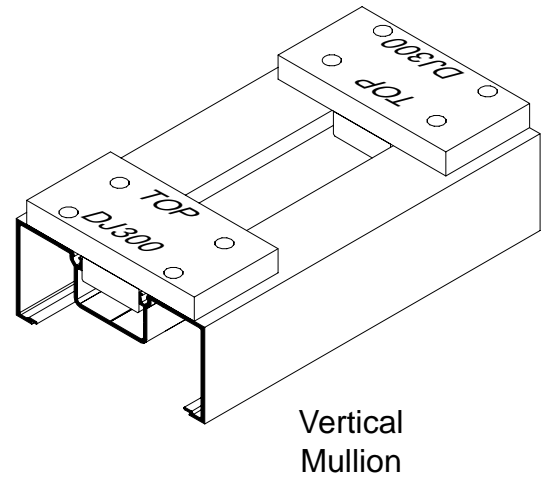
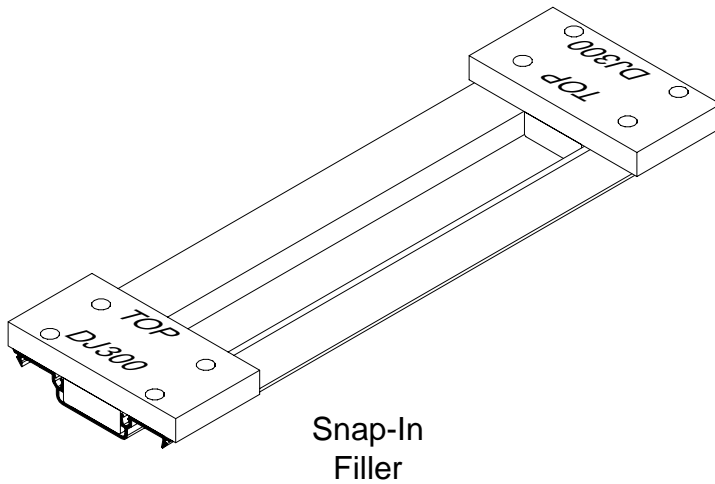

FRAME FABRICATION

STEP 4.

Drill or punch holes in verticals for attaching horizontals.

Use Letter "F" (.257 Ø) Drill

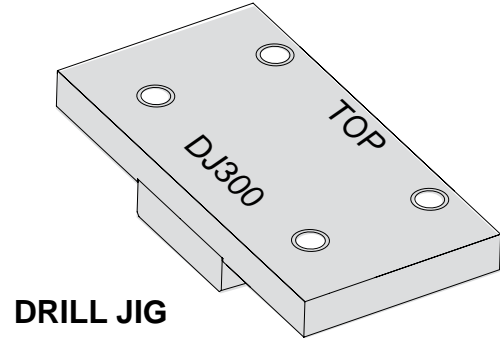
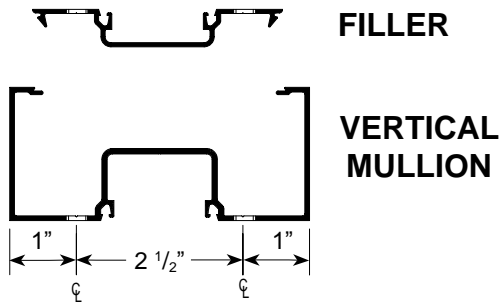

EXTERIOR GLAZING

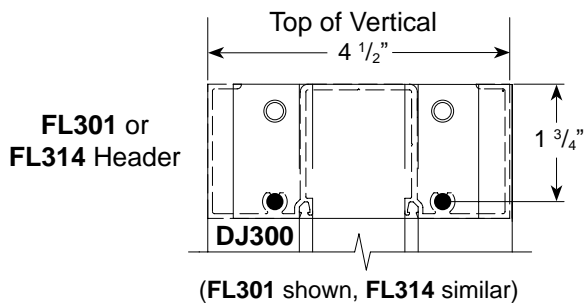

INTERIOR GLAZING

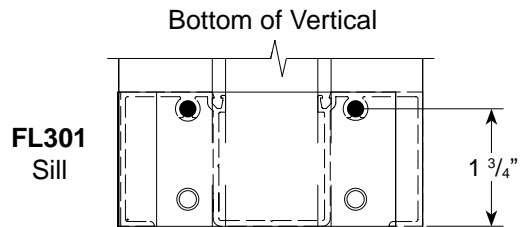
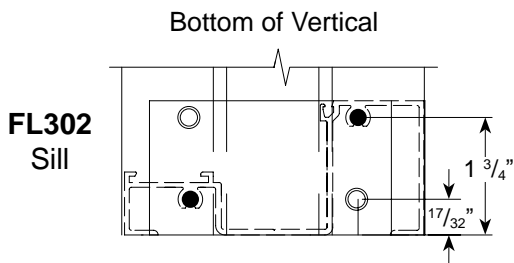
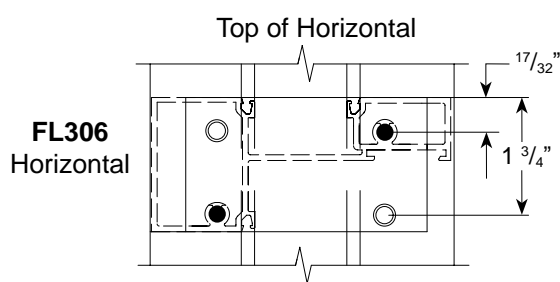
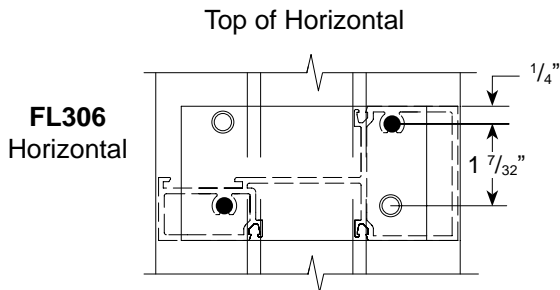
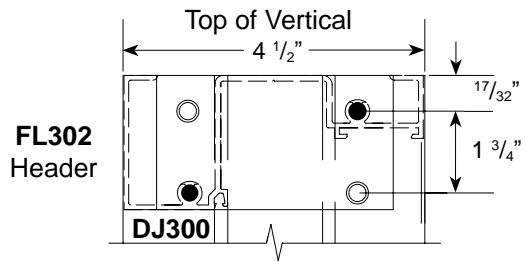

Vertical at door jamb extends to floor

Vertical at door jamb extends to floor

FRAME FABRICATION

STEP 5.

Fabricate steel reinforcement where required.

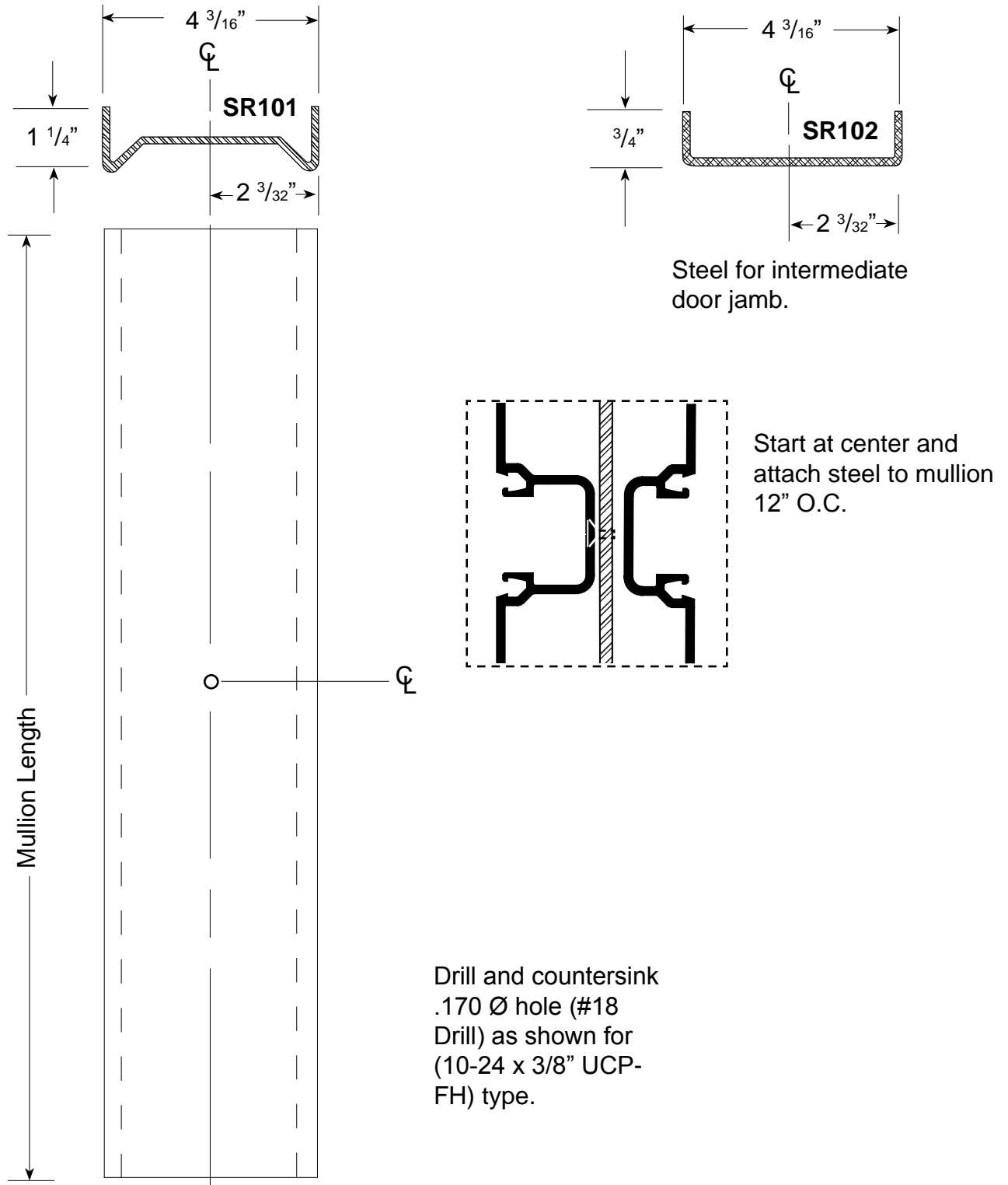

FRAME FABRICATION

STEP 6.

Fabricate head and sill anchor holes. Reference anchor charts for number of anchor holes and locations for each substrate. First hole is always 2" from end. Each additional fastener hole is located at required minimum spacing between fasteners based on substrate as shown in anchor charts.

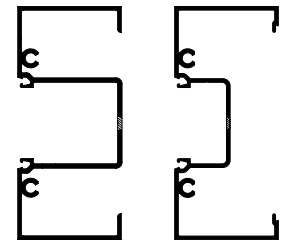
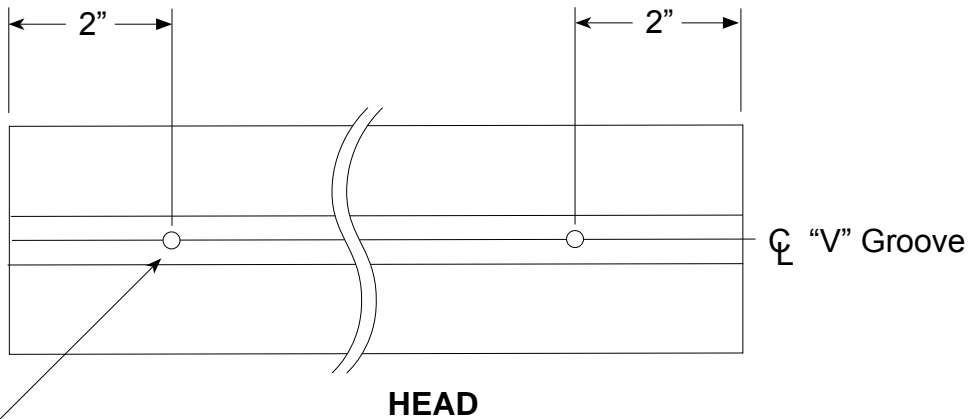

Clear hole for 1/4" Ø fastener **FL301**
Drill 1/2" clear hole for 1/4" Ø fastener **FL314**.

Note: **CS104** flat filler plate must be used for attaching **FL314** to substrate.

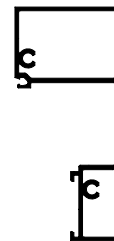
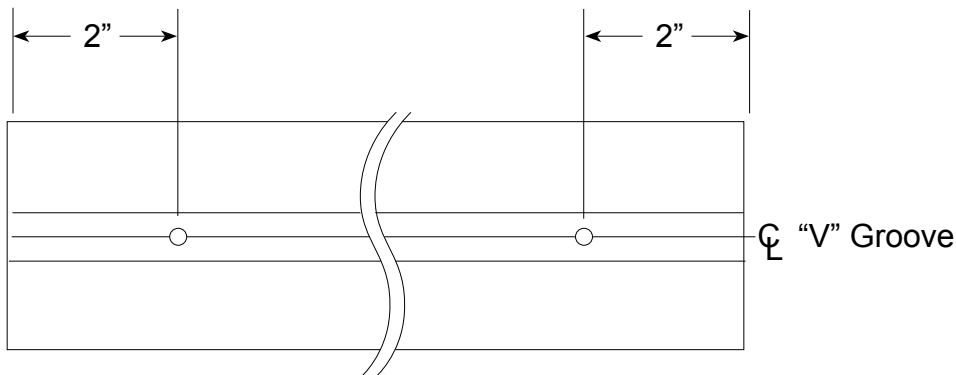

SILL

FRAME FABRICATION

STEP 7.

Fabricate wall jamb for anchor holes when required. (Reference Anchor Charts).

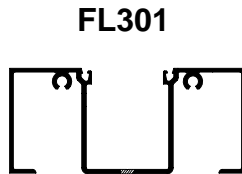

or

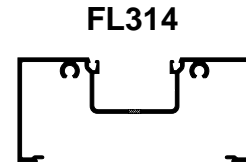

Note: CS104 flat filler plate must be used for attaching FL314 to substrate.

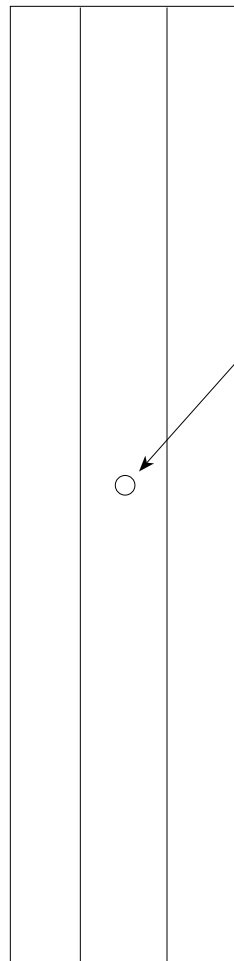

Clear hole for 1/4" Ø fastener at FL301
Drill 1/2" Ø hole for FL314.

Note:
Do not locate anchor hole at intersection of intermediate horizontal. Locate hole just above or below horizontal. Check anchor chart for spacing and quantity based on substrate.

WALL JAMB

FRAME FABRICATION

STEP 8.

Fabricate **FL319** subsill flashing for end dams and non-structural fastener holes. Hole location dimensions for fasteners in subsill are approximate. Use rear or front "V" groove lines for non-structural fasteners.

SUBSILL FLASHING

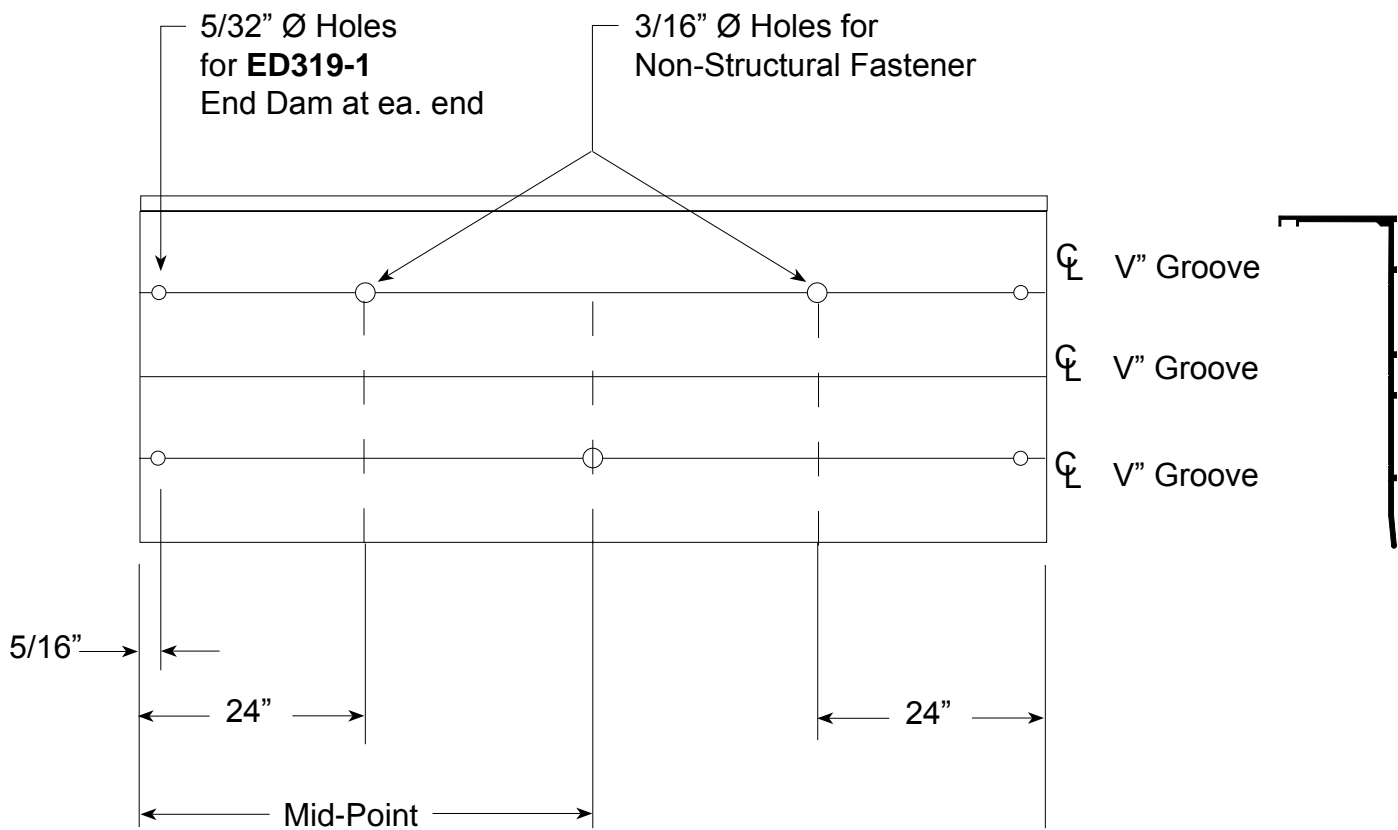

1. Drill 3/16" Ø hole for non-structural fasteners used for attaching subsill to substrate as shown. Repeat this hole pattern for each additional 12'-0" of length or as required to temporarily hold subsill in place until structural fasteners are installed (See **Step 3 Page 17**). Holes may be located on the inside or outside of "V" groove or staggered.
2. Drill two each 5/32" Ø holes at each end (except end abutting a door jamb) for attaching **ED319-1** end dams. Countersink for (#10-24 x 3/8" UCPFH) screw.

FRAME ASSEMBLY - OUTSIDE GLAZING

STEP 1.

Note:
Shallow glazing pockets
cannot face each other.

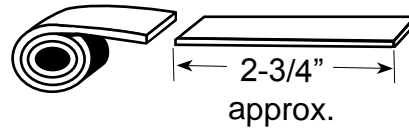

Schnee-Morehead **SM5601**
1/8" x 1/2" Tacky Tape.

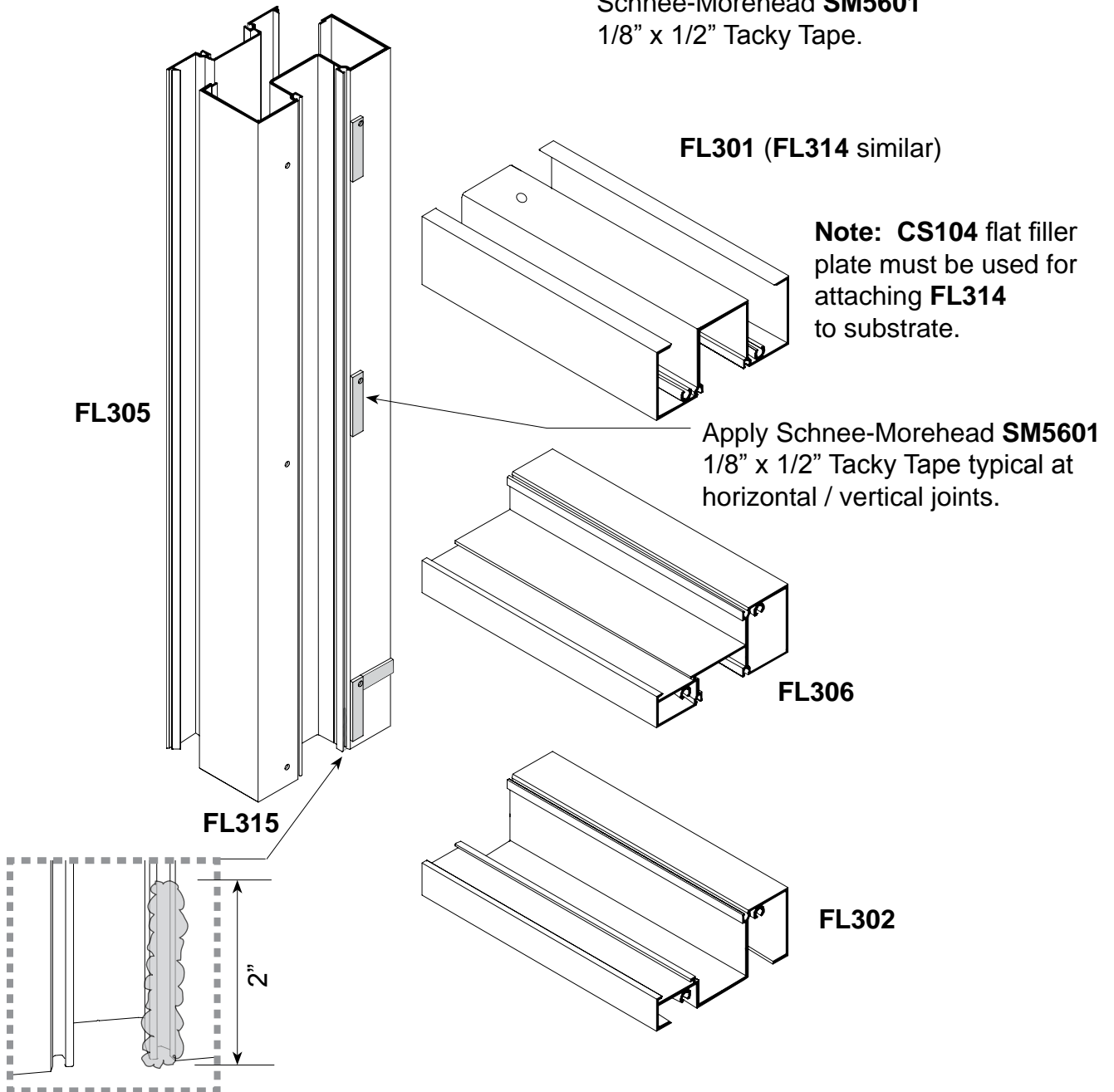

CRITICAL SEAL: Completely fill gasket reglet with **DOW 795** sealant at bottom as shown.
Attach horizontals to verticals using **AS16** (#14 x 1" HHSTS spline screws). See **Page 7** for hole prep locations.

FRAME ASSEMBLY - INSIDE GLAZING

STEP 1.

Note:

Shallow glazing pockets cannot face each other.

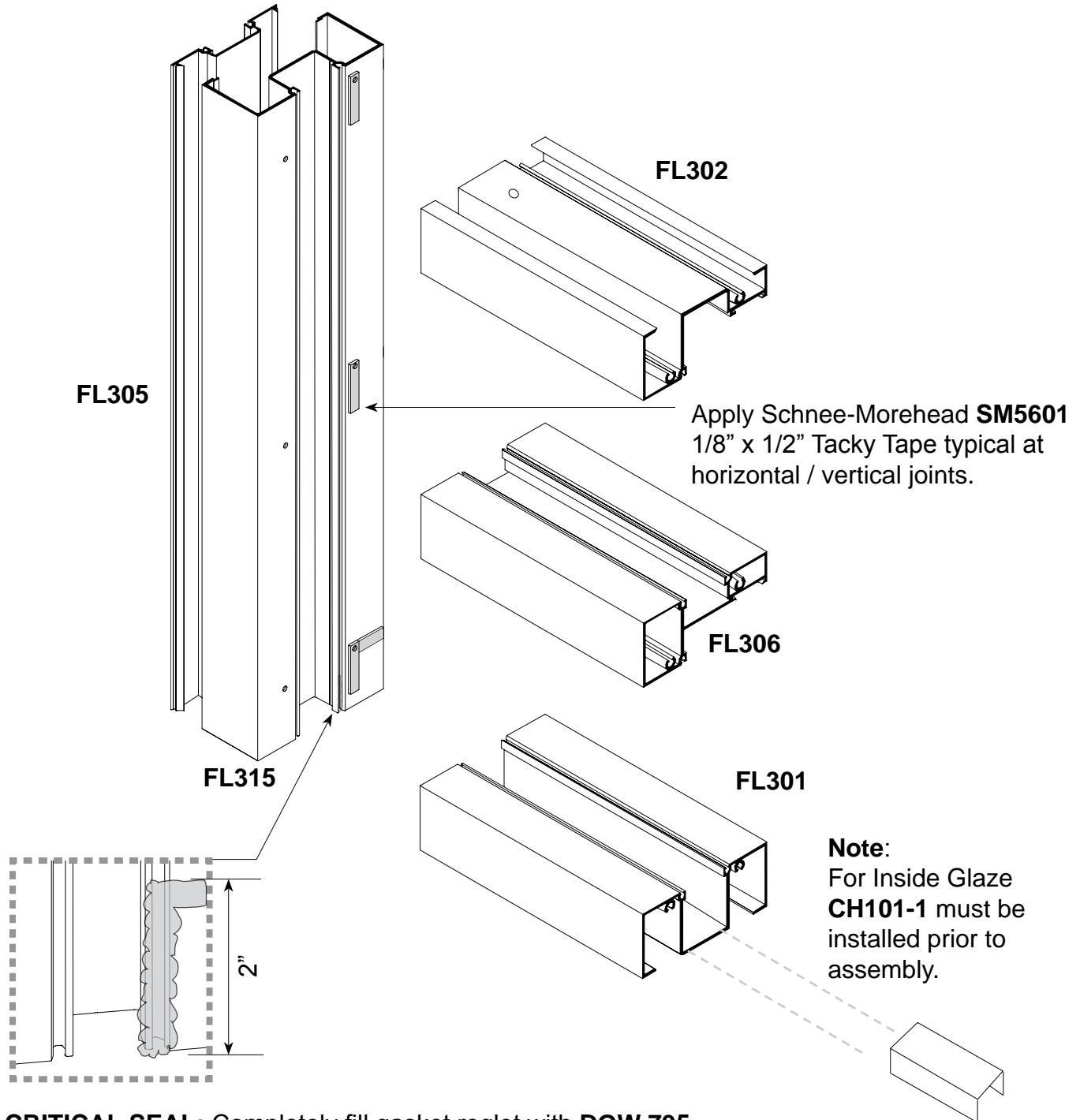

CRITICAL SEAL: Completely fill gasket reglet with **DOW 795** sealant at bottom as shown.
Attach horizontals to verticals using **AS16** (#14 x 1" HHSTS spline screws). See **Page 7** for hole prep locations.

FRAME ASSEMBLY

STEP 2.

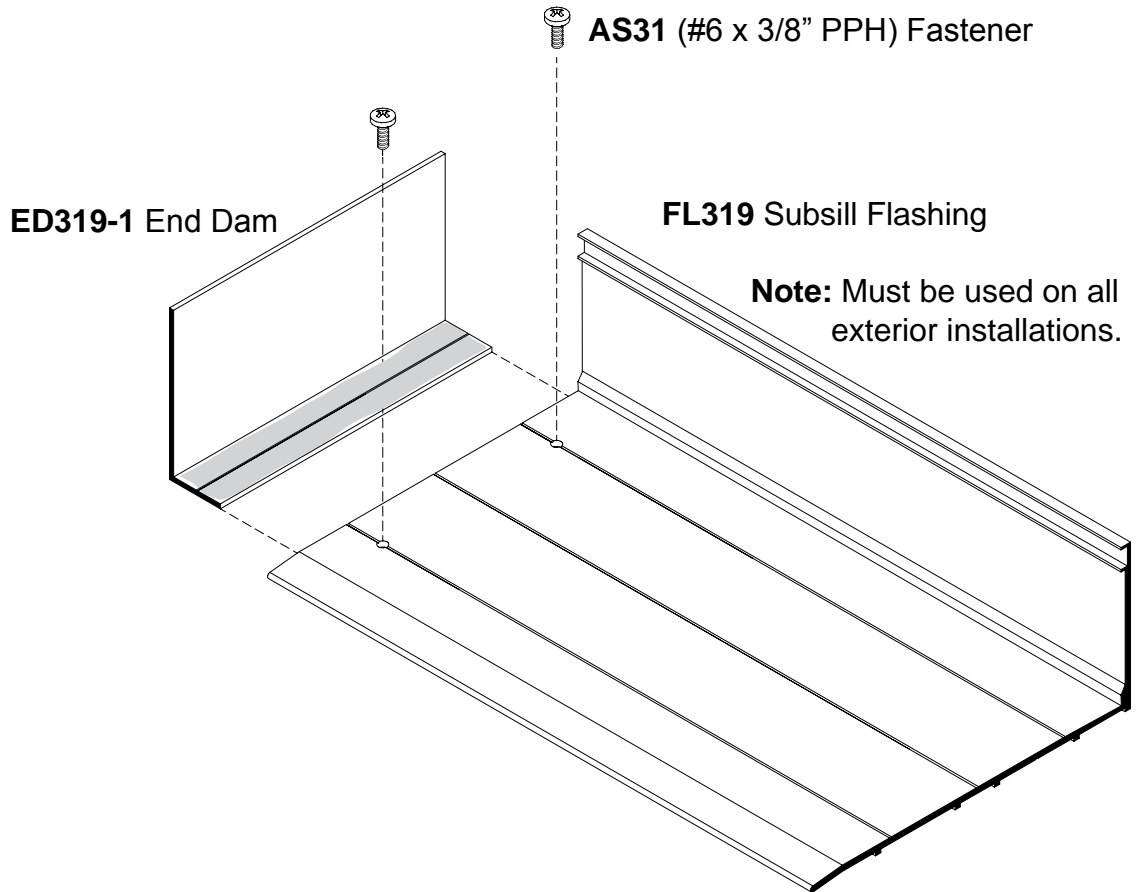

Apply **DOW 795** sealant to end dams as shown and attach to each end of subsill. Match drill holes in subsill to end dam with 5/32" Ø drill and attach as shown.

FRAME INSTALLATION

STEP 1.

Center subsill into opening allowing for a 1/4" minimum shim space at each end to ensure a good caulk joint.

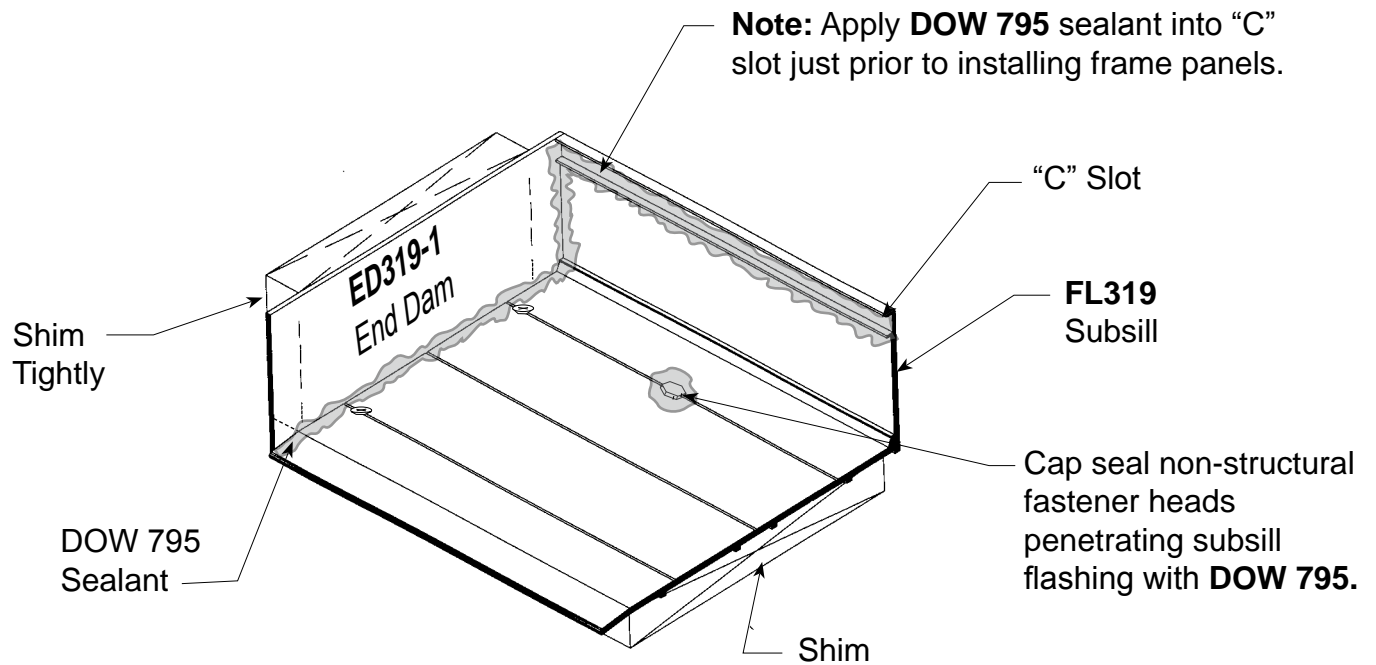

Shim beneath subsill to be a minimum of 1/4". Attach subsill flashing to structure with non-structural fasteners using attachment holes shown on **Page 11**.

Wedge shims tightly between end dams and jamb substrate on each end prior to installing frame panels. These shims prevent the end dam from dislodging while frame panels are being installed. Completely seal end dams as shown.

Run a continuous bead of **DOW 795** sealant along the full length of the subsill "C" slot as shown above just prior to installing frame panels. Do not allow sealant to harden prior to installing frame panels. Remove excess sealant after panels are installed.

FRAME INSTALLATION

STEP 2.

Screw spline joinery allows for frames to be shop fabricated into panels and shipped to job site assembled. Each panel must have at least one vertical deep pocket for glazing. Arrange panels so that two shallow pockets never face each other. **Reference Page 12 (FRAME ASSEMBLY).**

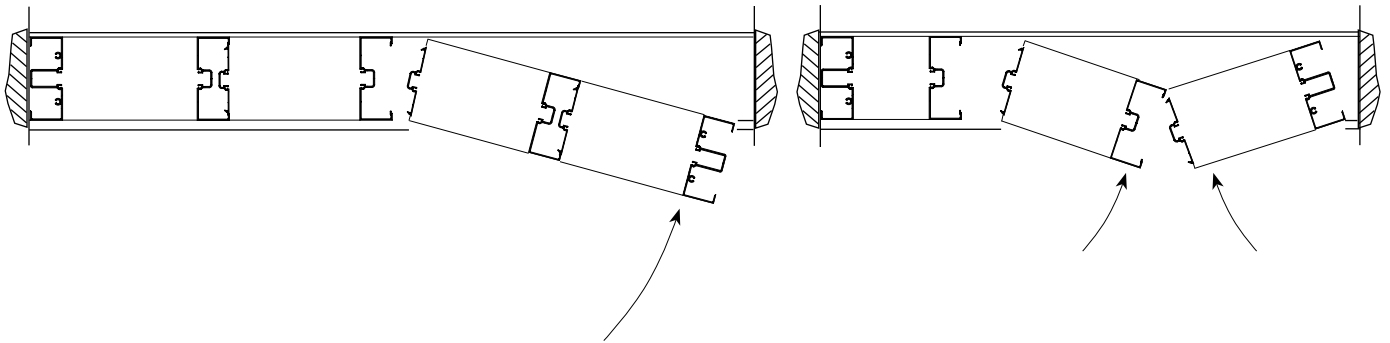

Detail A
Typical Elevations

Expansion mullions should be used in elevations exceeding 24'-0" in width to allow for thermal movement. See **Page 31** for formula.

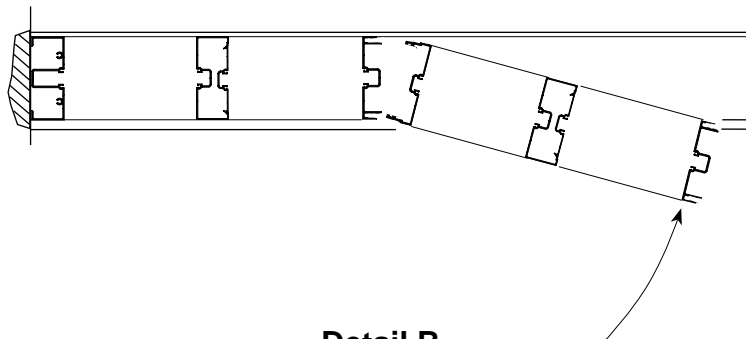

Detail B
Elevations with Expansion Mullions

FRAME INSTALLATION

STEP 3.

After all panels are installed, shim beneath subsill at fastener location. Match drill holes through sill into substrate. Remove dust from hole and apply **DOW 795** sealant as shown below into anchor holes prior to anchoring with structural fasteners. Cap seal fastener heads with **DOW 795**. Match drill holes through head into substrate, anchor and shim as shown.

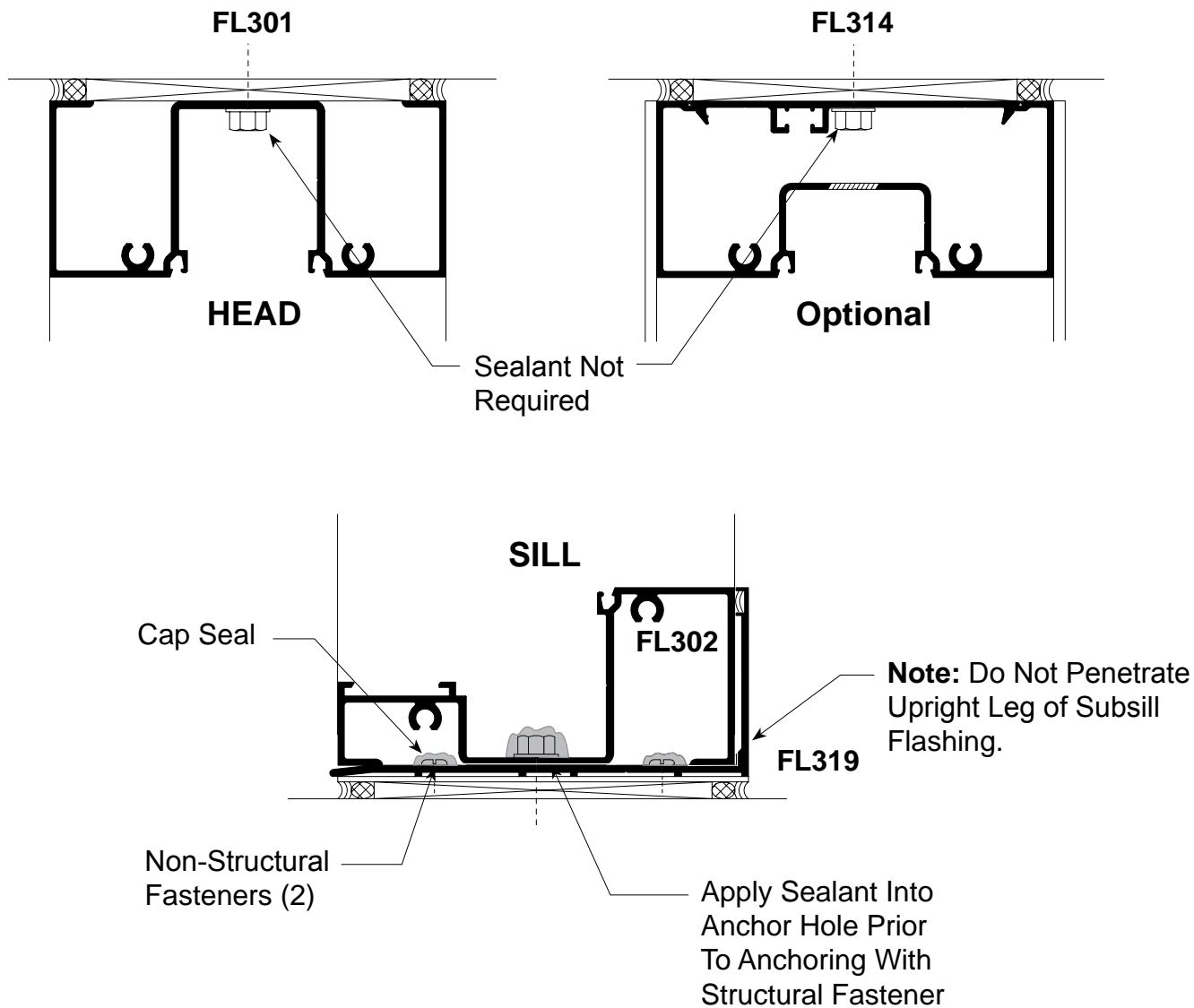

FRAME INSTALLATION

STEP 4.

In high wind load areas, it may be necessary to attach jamb to substrate as shown. When required, match drill holes in jamb to substrate. Anchor and shim as required. Cap seal fastener heads with **DOW 795**.

When all frames are secured to the opening, then completely seal exterior and interior perimeter with a continuous bead of **DOW 795** sealant.

Completely Seal
Exterior & Interior
Perimeter of Frame.

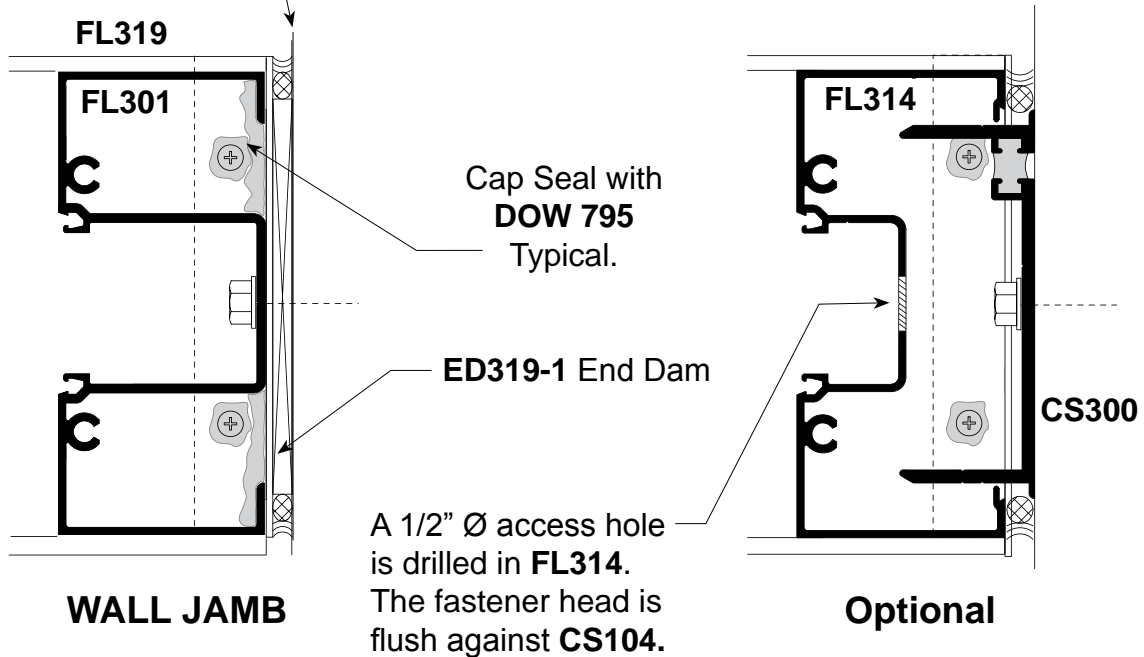

PREPARATION OF FRAME OPENING FOR GLASS

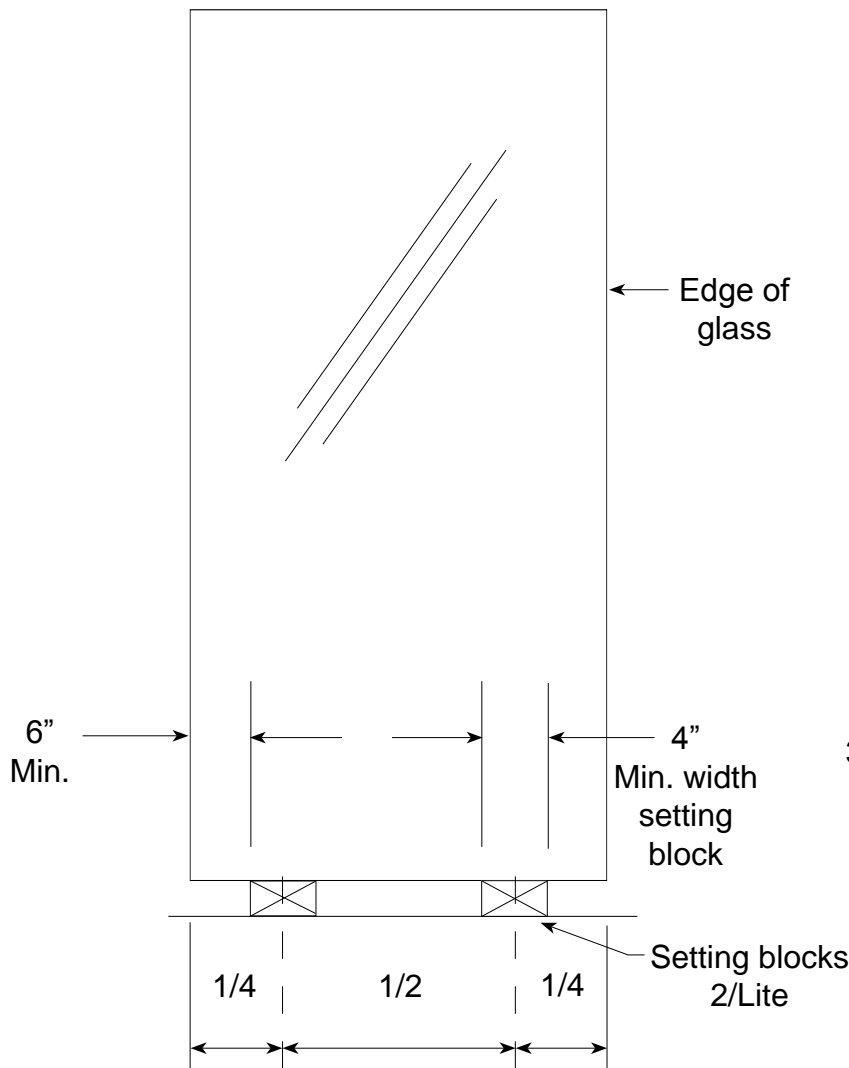

1. Prepare the frame opening by removing all dirt and debris from the glazing pockets and gasket reglets.

2. SETTING BLOCKS

Glass should be set on two identical setting blocks having a Shore A Durometer of 85 + or -5. The preferred location is at the 1/4 points.

If the 1/4 point location causes excessive deflection of the intermediate horizontal, move the setting blocks equally towards the corners of the lite as far as the 1/8 points. The outer end of the block **CANNOT** be closer than 6" to the corner of the glass.

3. DEFLECTION

The intermediate horizontal must not exceed 1/8" and a door header is limited to 1/16". Check dead load charts for proper setting block locations.

INSTALLATION OF TOP LOAD GLAZING GASKETS

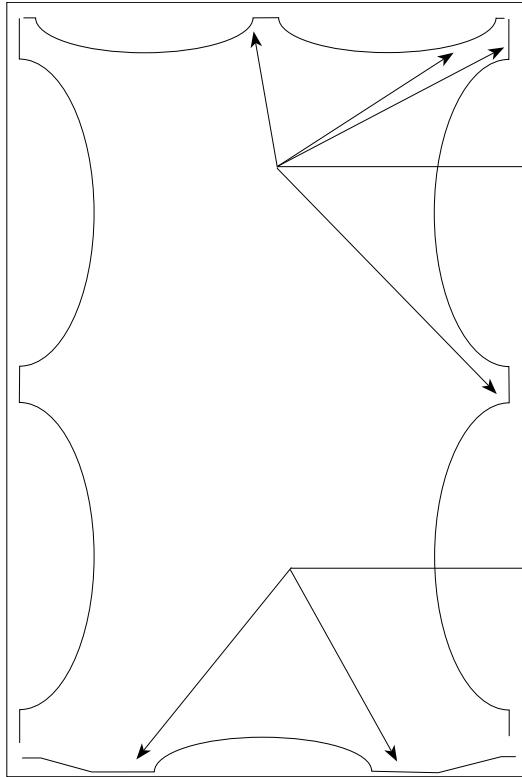

Detail A

Start jamb and head gaskets at corners and center.

1. Cut gaskets a minimum of 3/16" longer per foot than aluminum extrusion.

2. Do not stretch gasket to make them fit.

Start gaskets at setting blocks.

It is very important that gaskets are installed correctly as shown in **Detail "A"**, to prevent shrinkage at corners.

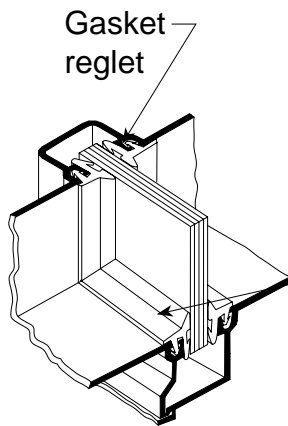

Seal corners of Gaskets.

3. Pull gaskets back 2" in both directions at corner intersections & seal with **DOW 795/995** silicone. This should be done on interior & exterior for best performance.

EXTERIOR GLAZING

GLASS SIZES*

GLASS SIZE = DAYLIGHT OPENING + 7/8"

Consult glass manufacturer for glass tolerance before ordering glass.

* (See door frame instructions for glass size at transom.)

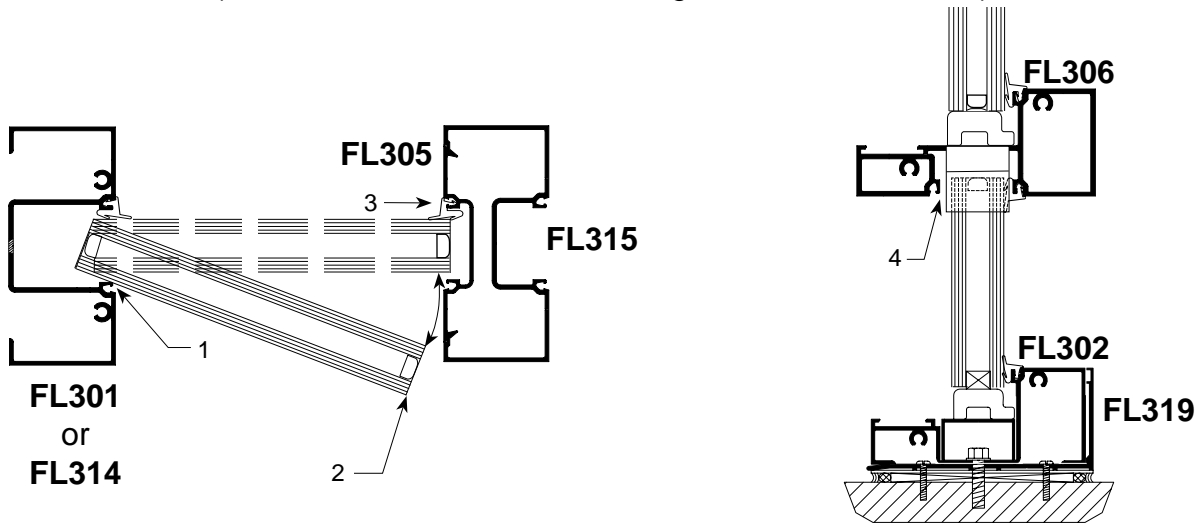

1. Install interior gasket. Vertical gasket runs through. **Reference Pages 19 & 20.**
2. Set glass in place following the four step procedure shown above. Center glass in the opening, making sure proper glass penetration is achieved. Rest glass on setting blocks.
3. Press glass against installed gaskets and snap-in **FL303** Glass Stop as shown below.
4. Install **NG1** exterior gaskets as shown on **Page 20.**

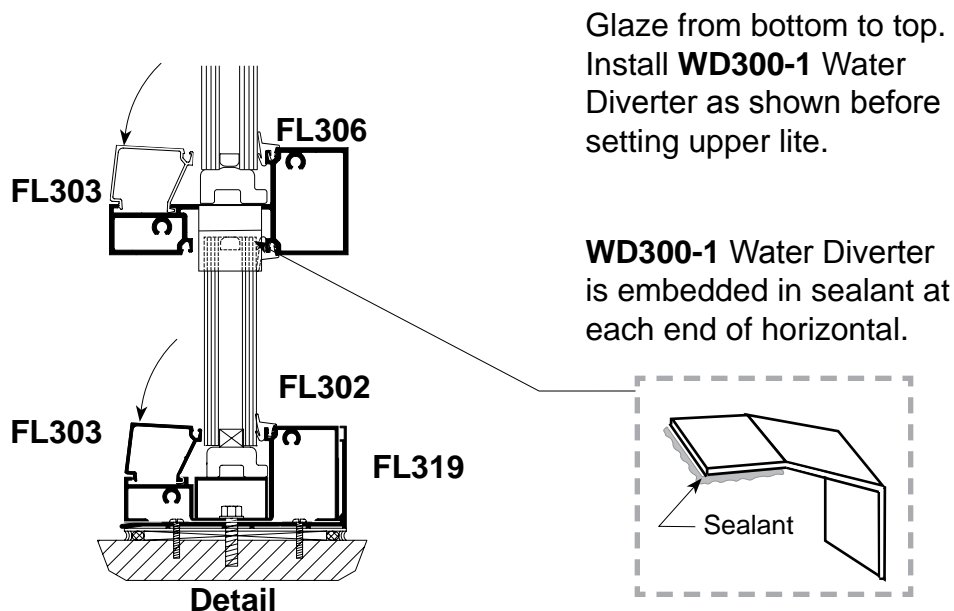

INTERIOR GLAZING

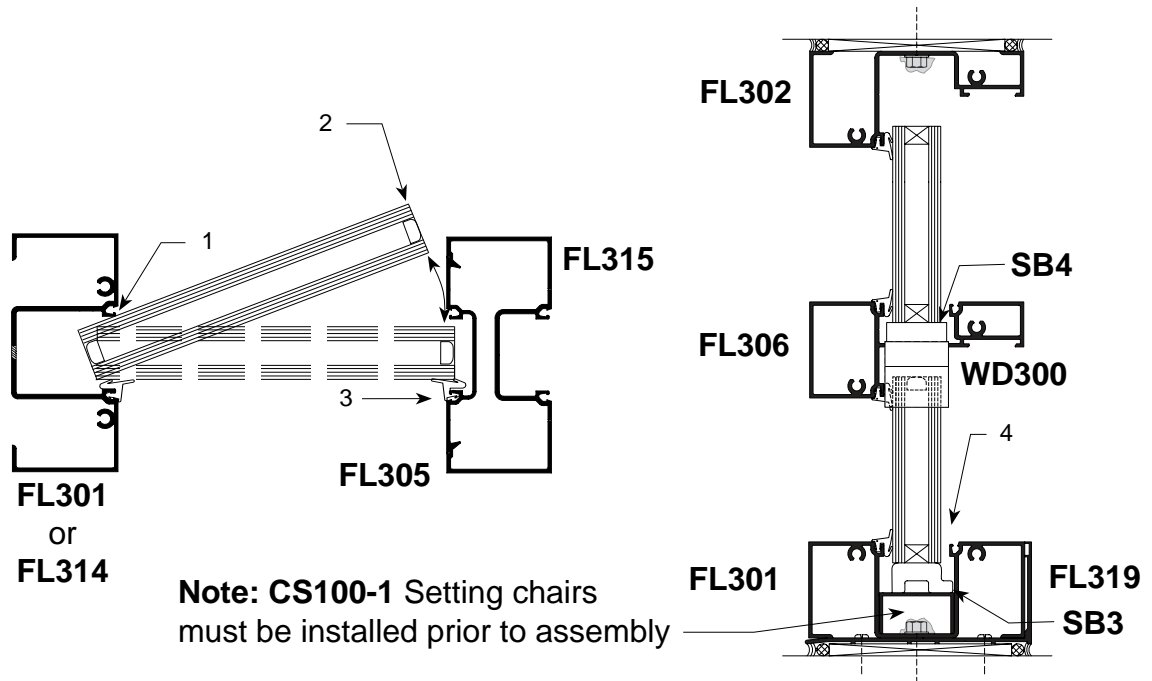

Note: CS100-1 Setting chairs must be installed prior to assembly

1. Install exterior gaskets. Vertical gasket runs through. **Reference Pages 19 & 20.**
2. Check deadload charts and shop drawings for correct setting block locations for intermediate horizontals. Position **SB4** setting blocks in horizontal and **SB3** sill members. Rest glass on setting blocks and press glass against installed gaskets.
3. **SEE BELOW.** Center glass into opening following the four step procedure shown above taking care not to disturb exterior gasket. Rest glass on setting blocks.
4. Press glass against installed gaskets snap-in **FL303** Glass Stop as shown below.
5. Install **NG1** interior gaskets as shown on **Page 20.**

Glaze from bottom to top. Install **WD300-1** Water Diverter as shown before setting upper lite.

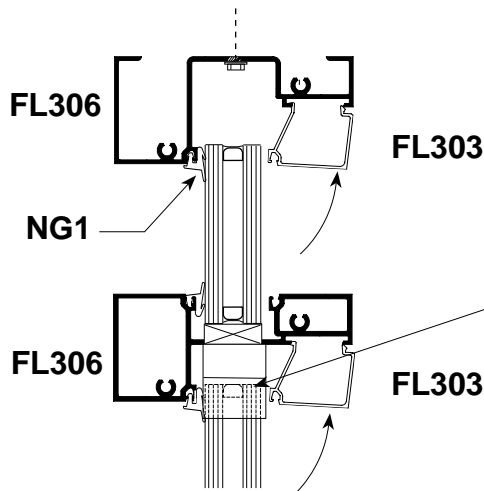

WD300-1 Water Diverter is embedded in sealant at each end of horizontal.

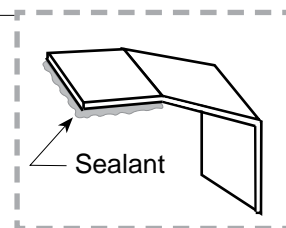

ENTRANCE DOOR FRAME INSTALLATION WITH SUBSILL FOR SIDELIGHTS

Where entrance doors occur, install entrance door frames first.
Subsill butts against door jamb.
The subsill abutting the door jamb does not require an end dam.

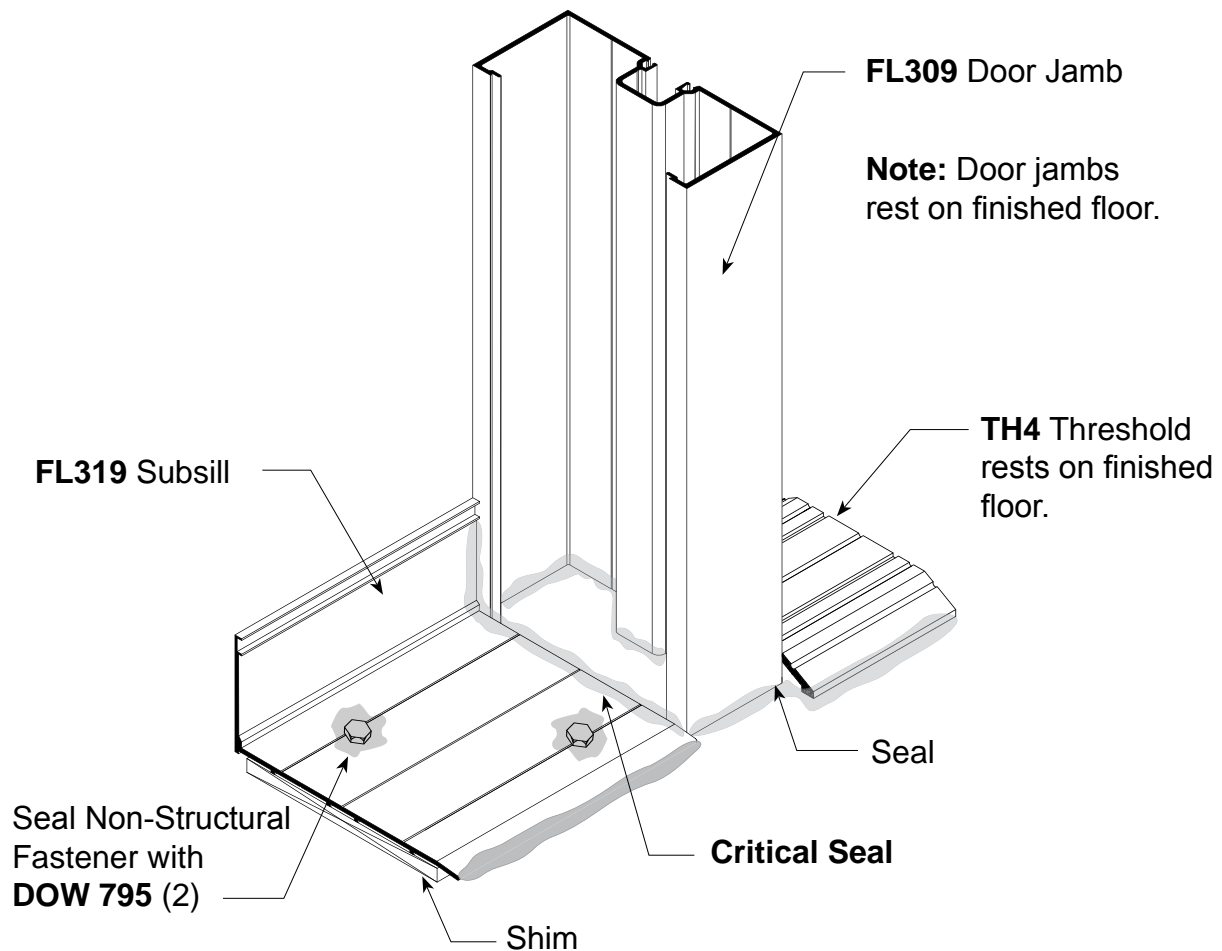

Note: Subsill perimeter sealant is applied after frame panels have been installed and anchored.

PREPARATION OF DOOR FRAME

All hardware back-up plates are installed in the frame at the factory. Door stops and transom sash are cut to length in the factory. Stock transom frames are fabricated for a vertical frame size of 10' - 5 1/2". If your opening is smaller, cut the verticals members down to the appropriate length. Leave a minimum 1/4" caulk joint at the head. The fabrication for the transom head horizontal should be made using either a drill fixture or punch die set for Series **FL300** framing. (See **Page 7 for hole locations**). Review frame anchor charts for configuration and for substrate to which the frame will be attached. Drill anchor holes into door jamb at wall and **CS104** flat filler. Apply **DOW 795/995** sealant to joint intersections at door header and transom head. Assemble frame with **AS16** spline screws. Use threshold clips as shown on **Page 25** for attaching threshold. Install transom sash if applicable. The frame is now ready for installation.

THRESHOLD FABRICATION

Note:
See *Entrances and Frames Installation Instructions* for detailed instructions.

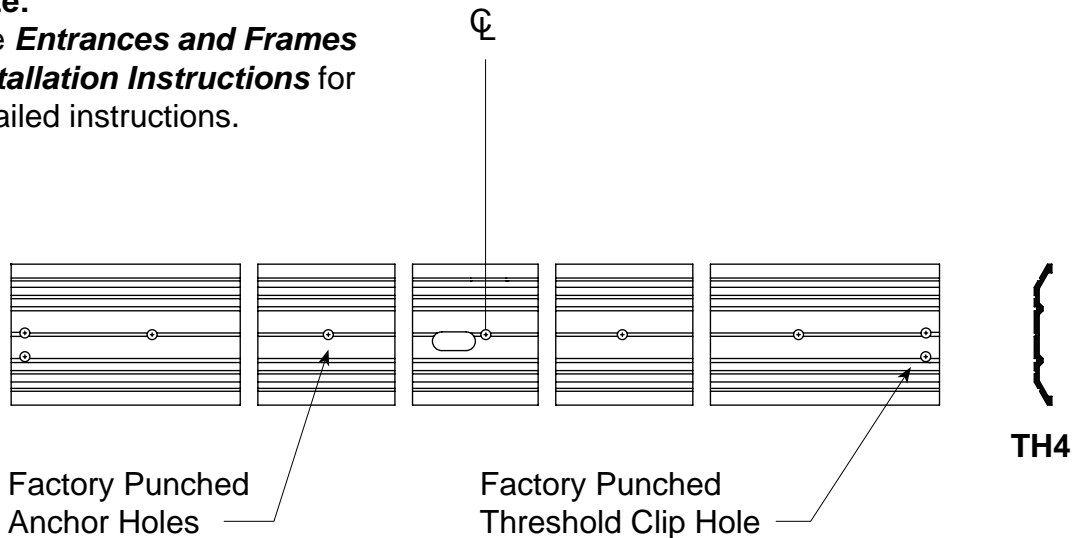

Threshold For Door Pair. (Butt Hung Shown, Offset Pivot Similar.)

INSTALLATION OF DOOR FRAME

1. Door frame and threshold shall be completely assembled with joints neatly aligned and tight.
2. Door frame shall be installed square and plumb. Measure frame diagonally from corner to corner and shim until the measurements are equal.
3. Level door frame threshold. The door frame is designed to have the jambs extend to floor.
4. Install fasteners through frame and threshold anchor holes and securely anchor to the substrate. Position shims between framing and substrate to prevent members from bowing.
5. Install door stops.
6. You are now ready to install the door.

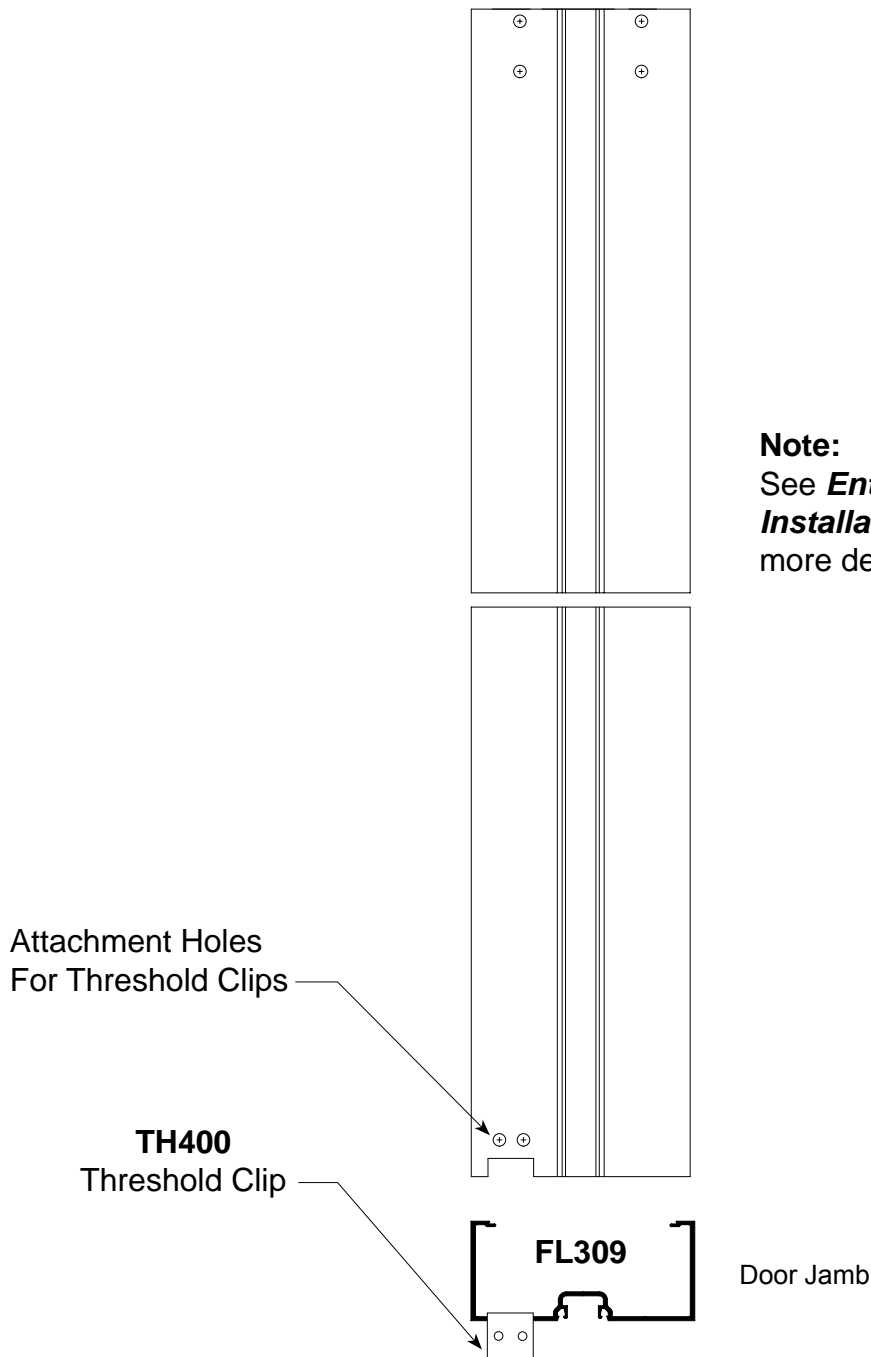

DOOR PREPARATION AND GLAZING

Door glass stops and gaskets are shipped loose.

SB1

Side Block
& Setting Block

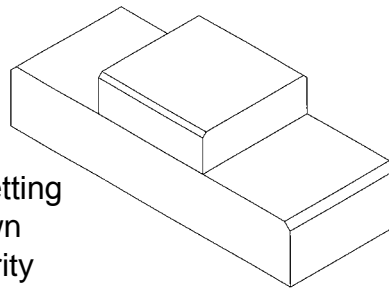

Side Block & Setting Block are Shown Inverted for Clarity

For 1" Glass (Rotate 90°
From 1/4" Position)

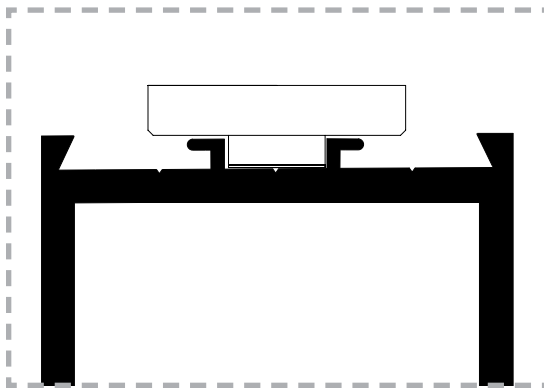

For 1/4" Glass

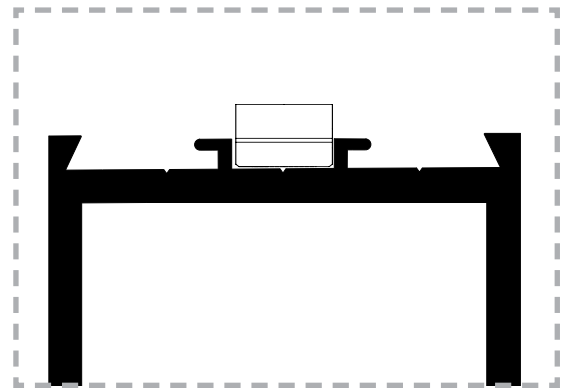

DOOR PREPARATION AND GLAZING

1. Install **DG100-1** glass stops on interior side of door.
2. Center glass in opening on setting blocks and align with side blocks.
3. Once the glass is in the correct position, lightly screw the glass adjustment screw down with **SP101** plastic tip attached to the top of the glass.
4. Install horizontal door glass stops.
5. Square door using adjustment screw located in top rail of door as required.

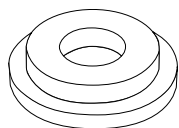
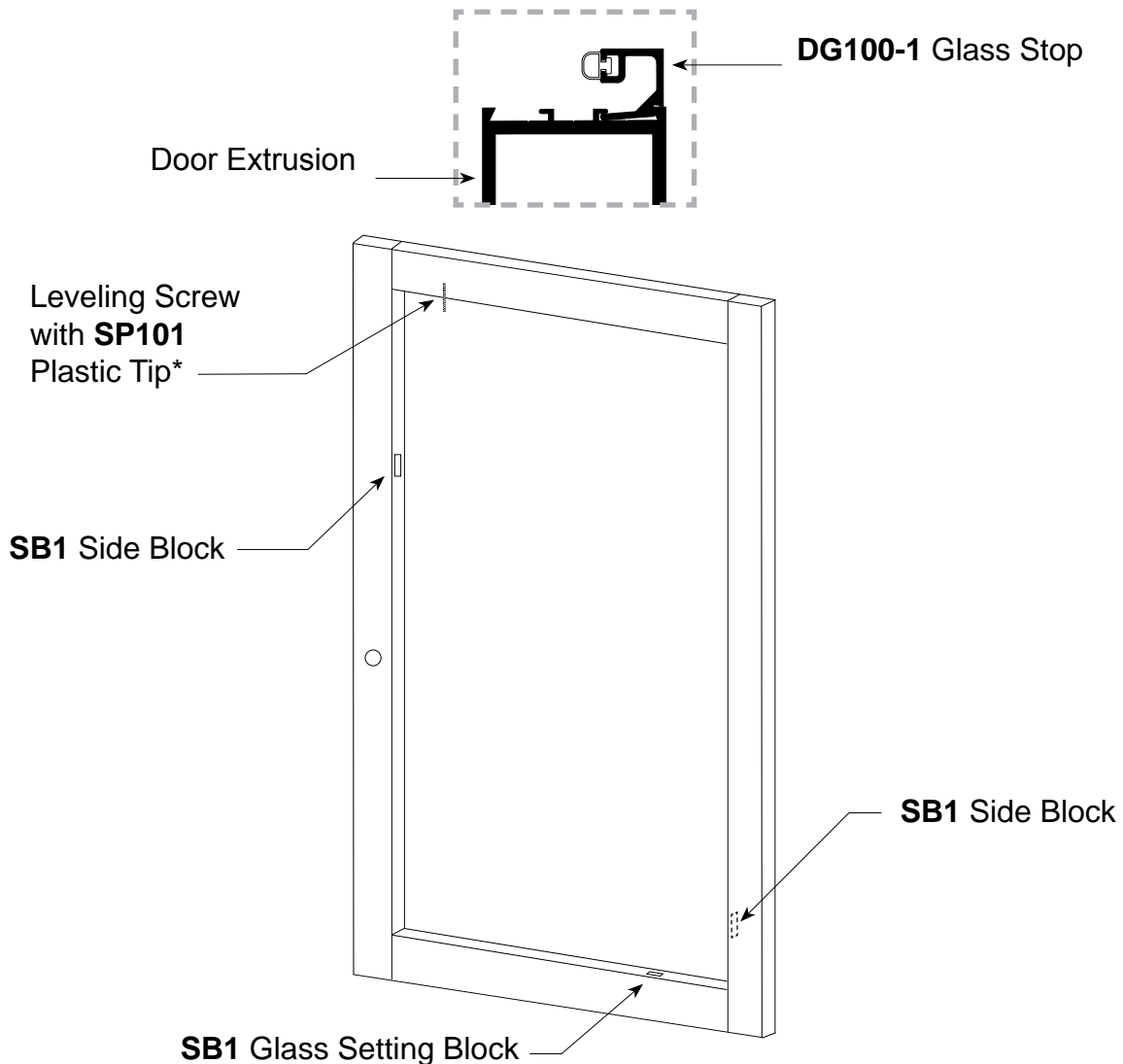

SP102

* If 1" glass is being glazed into door, install **SP102** plastic tip over **SP101**.

SPECIAL CONDITIONS 90° CORNER

1. Install mitered subsill on one side of corner first and attach with non-structural fastener. Install adjoining subsill to form corner and secure it to structure. Cap seal over all fasteners. Apply bond breaker tape along full depth of mitered joint and seal joint with **DOW 795** silicone.
2. Set left corner panel first. Attach horizontals of right panel to right side of corner with **AS16** fasteners. **See Fig. "A"**. Re-seal any damage sealant at mitered joint of subsill. Anchor head and sill to substrate as shown on **Page 16**.
3. The corner trim can be installed after the right panel is completed. **See Fig. "B"**.

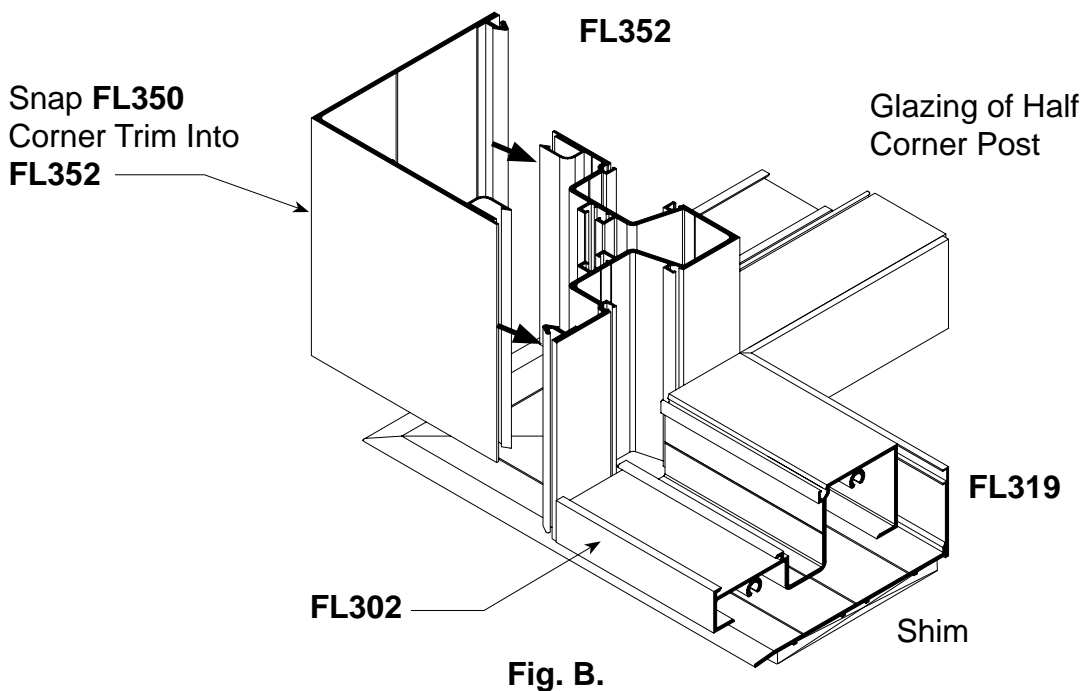
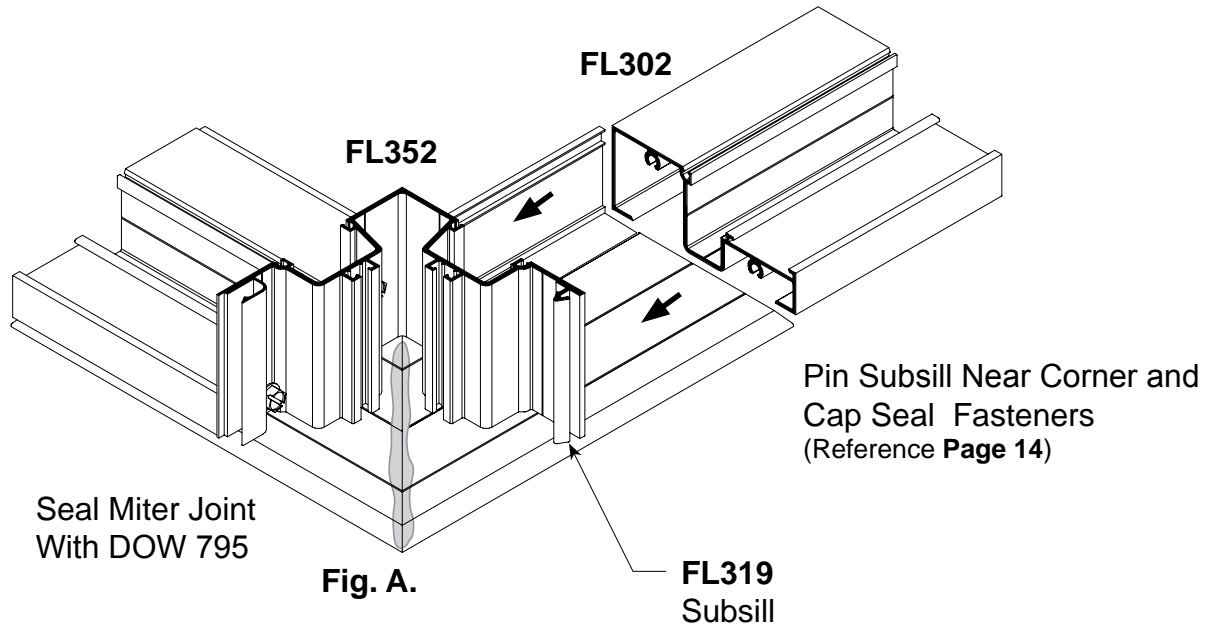

SPECIAL CONDITIONS 135° INSIDE / OUTSIDE CORNERS

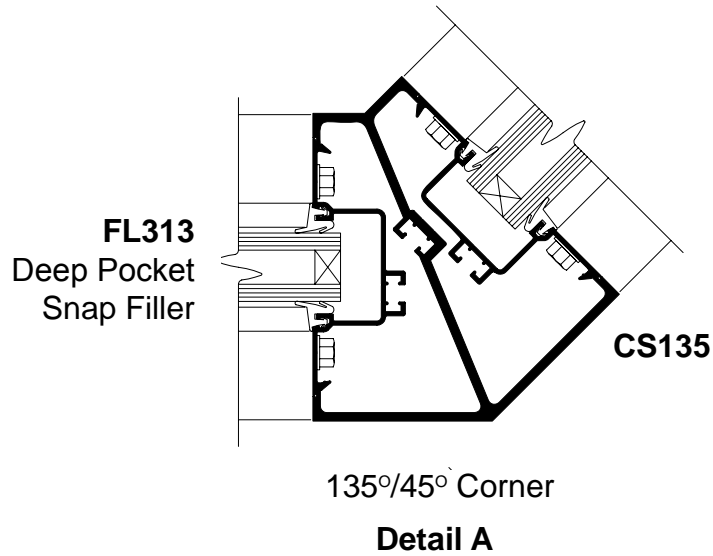

BREAK METAL ANGLE CORNERS

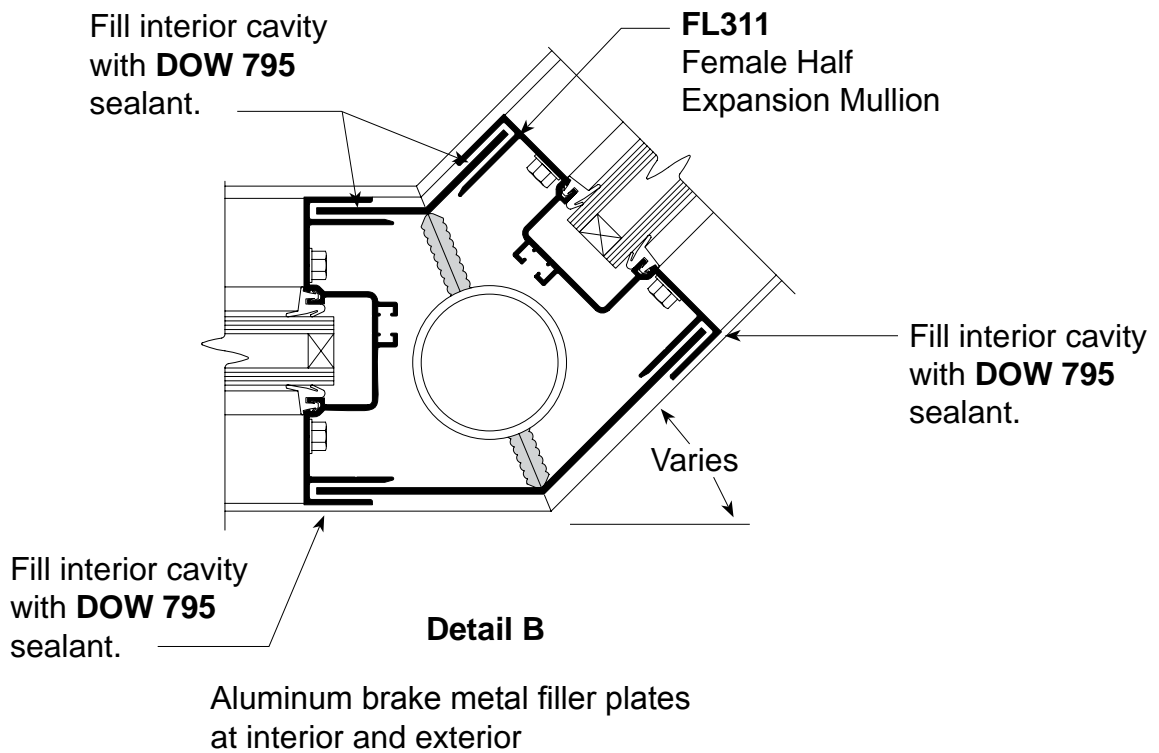

SPECIAL CONDITIONS TRANSITION GLAZING

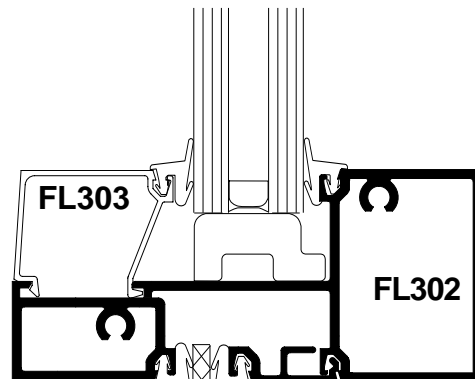
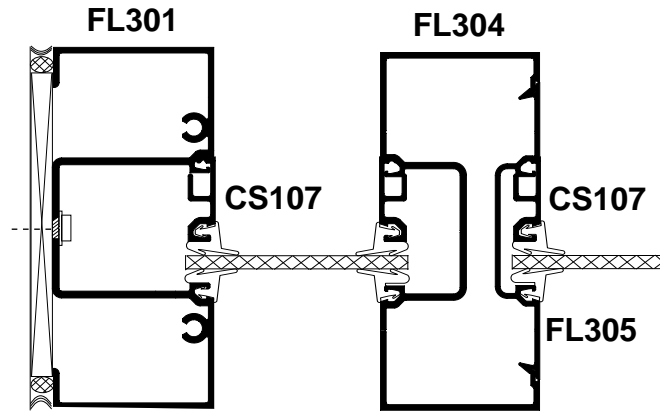

CS107 - Shown for
1/4" Glazing



CS108 - For 3/8"
Glazing similar



CS109 - For 1/2"
Glazing similar

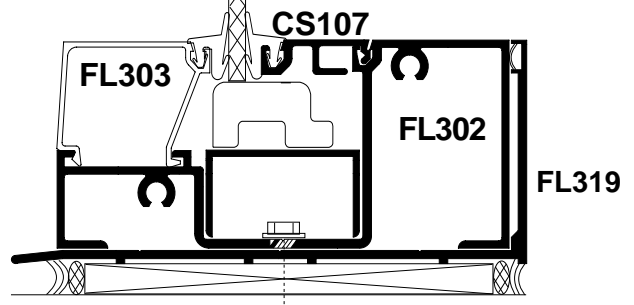

SPECIAL CONDITIONS SPLICE SLEEVE AT SUBSILL

STEP 1. Locate splice sleeves near center of D.L.O. at panel positioned over splice.

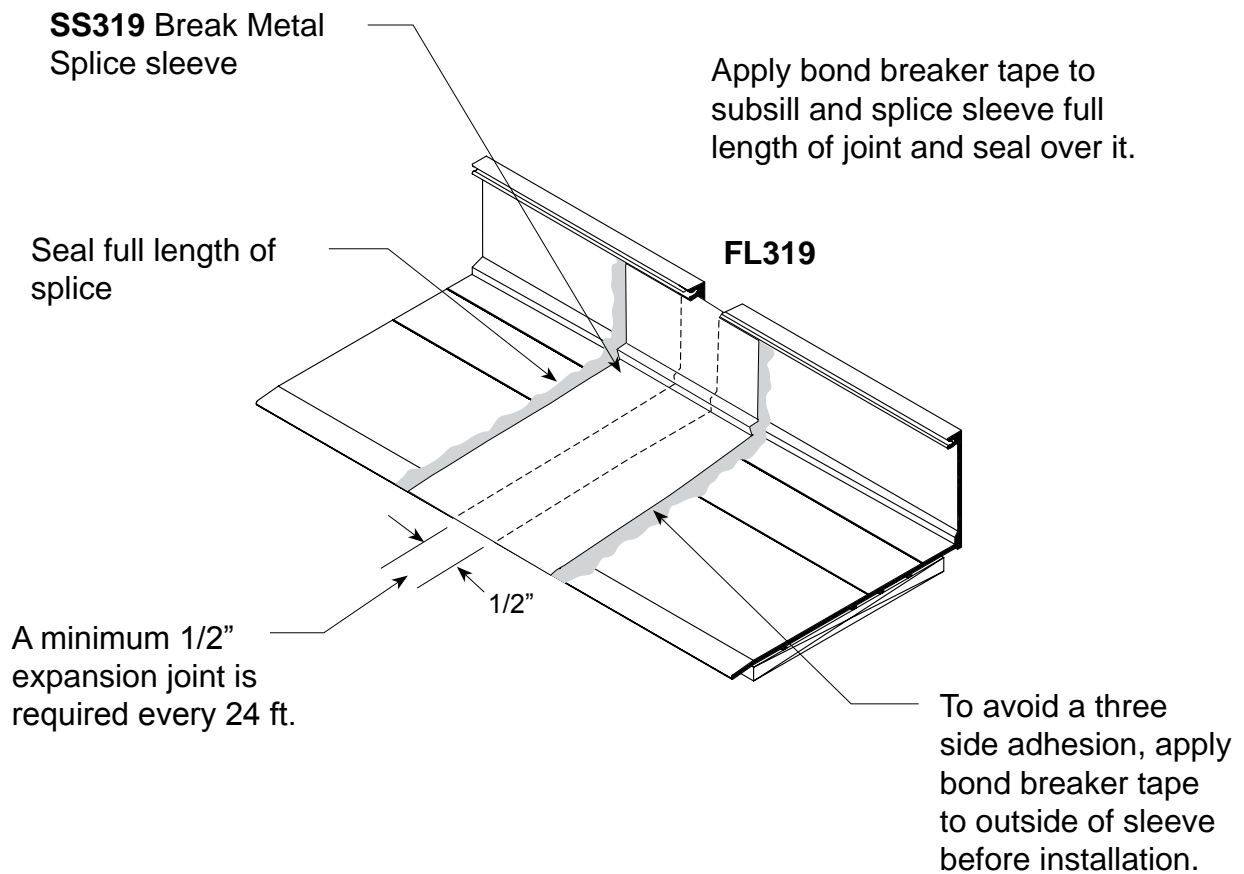

SPECIAL CONDITIONS EXPANSION MULLIONS

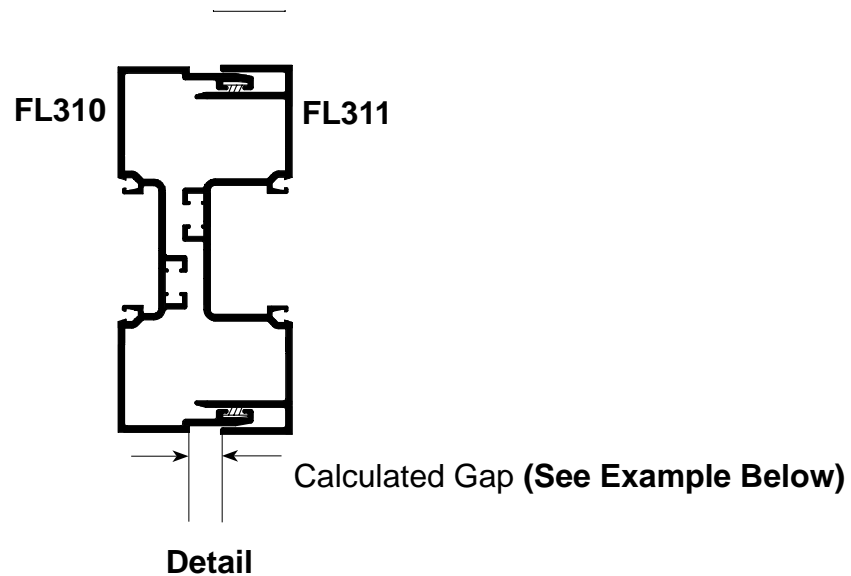

Calculated gap is determined by job conditions project specifications and temperature at the time of installation. Expansions mullions allow for 3/8" maximum movement.

EXPANSION GAP SIZE FORMULA= Length (") x F° difference x .0000129

L = Length in inches, between center line of expansion mullion in elevation.

F° = Specified Temperature Variation

.0000129 = Thermal Coefficient for Aluminum

FOR EXAMPLE:

Assume 100° temperature variation specified and temperature at job site on day of installation is 60°

1. $100^{\circ} - 60^{\circ} = 40^{\circ}$ temperature difference
2. Length of elevation between expansion mullions equals 20'- 0" or 240"
3. $240" \times .0000129 \times 40^{\circ} = .124"$ Therefore, set expansion mullion gap at .124" or 1/8".