

Section B1
 Table of Contents

FL200
 STOREFRONT SYSTEM
 1³/₄" X 4¹/₂"

	<i>Page</i>
Specifications - FL200	S1-S5
Features & Benefits	1
Standard Framing	2
Optional Framing.....	3-4
Corner Framing.....	5
Entrance Framing - Non-Transom.....	6
Entrance Framing - Single Acting with Transom	7
Entrance Framing - Double Acting with Transom	8
Wind and Dead Load Charts.....	9-11

FL200·1³/₄"x4¹/₂"
Non-Thermal Storefront



Page Left Intentionally Blank

GUIDE SPECIFICATION

Manufacturer:
Coral Architectural Products
3010 Rice Mine Road
Tuscaloosa, AL. 35406
Voice: (800) 772-7737
Fax: (800) 443-6261

SECTION 08410 ALUMINUM ENTRANCES AND STOREFRONT SYSTEMS

This suggested guide specification has been developed using the current edition of the Construction Specifications Institute (CSI) "Manual of Practice," including the recommendations for the CSI 3 Part Section Format and the CSI Page Format. The developmental concept and organizational arrangement used by the American Institute of Architects (AIA) MASTERSPEC Program were recognized in the preparation of this guide specification. Neither CSI nor AIA endorse specific manufacturers and products. The preparation of the guide specification assumes the use of standard contract documents and forms, including the "Conditions of the Contract," published by the AIA.

PART 1 – GENERAL

1.01 Summary

- A. Section Includes: Coral Architectural Products™, including perimeter trims, stools, accessories, shims and anchors, and perimeter sealing of storefront framing.
1. Types of Coral Architectural Products include:
 - a. Series FL200 1-3/4" x 4-1/2" non-thermal (outside) or (inside) center glazed storefront system for 1/4" or 3/8" glazing.

EDITOR NOTE: BELOW RELATED SECTIONS ARE SPECIFIED ELSE WHERE, HOWEVER, CORAL ARCHITECTUAL PRODUCTS RECOMMENDS SINGLE SOURCE RESPONSIBILITY FOR ALL OF THESE SECTIONS AS INDICATED IN 2.07 SOURCE QUALITY CONTROL.

- B. Related Sections:
1. Division 7 Section "Vapor Barriers" between glazed wall systems and adjacent construction
 2. Division 7 Section "Fire Stopping"
 3. Division 7 Section "Joint Sealants" for joint sealants installed as part of aluminum entrance and storefront system
 4. Division 8 Section "Glazed Aluminum Curtain Walls"
 5. Division 8 Section "Aluminum Windows Walls"
 6. Division 8 Section "Aluminum Entrances and Storefronts"
 7. Division 8 Section "Aluminum Mall Sliding Doors"
 8. Division 8 Section "Finish Hardware"
 9. Division 8 Section "Glass and Glazing"

EDITOR NOTE: REFER TO INDEX FOR ANY AND ALL APPLICABLE STANDARDS.

1.02 References (Industry Standards)

1.03 System Description

- A. Storefront System Performance Requirements:
1. Wind loads: Provide framing system; include anchorage, capable of withstanding wind load design pressures of () P.S.F. inward () P.S.F. outward. The design pressures are based on the () Building Code; () Edition.
 2. Air Infiltration: The test specimen shall be tested in accordance with ASTM E 283. Air infiltration rate shall not exceed 0.06 cfm/ft² at a (static) air pressure differential of 6.24 PSF.
 3. Water Resistance (static): The test specimen shall be tested in accordance with ASTM E 331 for (outside) or (inside). There shall be no leakage at a minimum static air pressure differential of 10 PSF as defined in AAMA 501.

GUIDE SPECIFICATION

4. Uniform Load: A static air design load of +60/-50 PSF (exterior glazed) and +40/-40 PSF (interior glazed) shall be applied in the positive and negative direction in accordance with ASTM E 330. There shall be no deflection in excess of L/175 of the span of any framing member at design load. At structural test load equal to 1.5 times the specified design load, no glass breakage or permanent set in the framing members in excess of 0.2% of their clear spans shall occur.

1.04 Submittals

- A. General: Prepare, review, approve and submit specified submittals in accordance with "Conditions of the Contract" and Division 1 Submittals Sections. Product data, shop drawings, samples and similar submittals are defined in "Conditions of the Contract."
- B. Quality Assurance/Control Submittals:
1. Test Reports: Submit certified test reports showing compliance with specified performance characteristics.

1.05 Warranty

- A. Project Warranty: Refer to "Conditions of the Contract" for project warranty provisions.
- B. Manufacturer's Product Warranty: Submit, for Owner's acceptance, manufacturer's warranty for storefront system as follows:
1. Warranty Period: Two (2) years from Date of Substantial Completion of the project. The Limited Warranty shall begin in no event later than six months from date of initial shipment by **Coral Architectural Products** without regard to the date selected as substantial completion.

1.06 Quality Assurance

- A. Qualifications:
1. Installer Qualifications: Installer experienced (as determined by contractor) to perform work of this section who has specialized in the installation of work similar to that required for this project and who is acceptable to product manufacturer.
 2. Manufacturer Qualifications: Manufacturer capable of providing field service representation during construction, approving acceptable installer and approving application method.
- B. Pre-Installation Meetings: Conduct pre-installation meeting to verify project requirements, substrate conditions, manufacturer's installation instructions and manufacturer's warranty requirements.

1.07 Delivery, Storage, and Handling

- A. Ordering: Comply with manufacturer's ordering instructions and scheduling requirements to avoid construction delays.
- B. Packing, Shipping, Handling and Unloading: Deliver materials in manufacturer's original, unopened, undamaged containers with identification labels intact.
- C. Storage and Protection: Store materials protected from exposure to harmful weather conditions. Handle storefront material and components to avoid damage. Protect storefront material against damage from elements, construction activities and other hazards before, during and after storefront installation.

PART 2 – PRODUCTS

EDITOR NOTE: RETAIN BELOW ARTICLE FOR PROPRIETARY METHOD SPECIFICATION; ADD PRODUCT ATTRIBUTES, PERFORMANCE CHARACTERISTICS, MATERIAL STANDARDS AND DESCRIPTIONS AS APPLICABLE. DO NOT USE THE PHRASE "OR EQUAL" / "OR APPROVED EQUAL," OR SIMILAR PHRASES. USE OF SUCH PHRASES CAN CAUSE AMBIGUITY IN THE SPECIFICATIONS DUE TO THE DIFFERENT INTERPRETATIONS AMONG THE DIVERGENT PARTIES OF THE CONSTRUCTION PROCESS AND READERS OF THESE SPECIFICATIONS. SUCH PHRASES REQUIRE EXTENSIVE AND COMPLETE REQUIREMENTS (PROCEDURAL, LEGAL, REGULATORY AND RESPONSIBILITY) FOR DETERMINING "OR EQUAL."

2.01 Manufacturers (Acceptable Manufacturers/Products)

- A. Acceptable Manufacturers:
1. Address: Coral Architectural Products, a division of Coral Industries
3010 Rice Mine Road
Tuscaloosa, AL. 35406

GUIDE SPECIFICATION

Contact Numbers:

- a. Telephone: (800) 772-7737
 - b. Fax: (800) 443-6261
 - c. Email: info@coralap.com
 - d. Web address: www.coralap.com
2. Proprietary Product(s)/System(s): Coral Architectural Products
 - a. Series: FL200 Non-Thermal Storefront System

EDITOR NOTE: RETAIN BELOW FOR ALTERNATE MANUFACTURERS/PRODUCTS AS SPECIFIED IN THE CONTRACT DOCUMENTS. COORDINATE BELOW WITH BID DOCUMENTS (IF ANY) AND DIVISION 1 ALTERNATES SECTION. CONSULT WITH CORAL ARCHITECTURAL PRODUCTS. FOR RECOMMENDATIONS ON ALTERNATE MANUFACTURERS AND PRODUCTS MEETING THE DESIGN CRITERIA AND PROJECT REQUIREMENTS, CORAL ARCHITECTURAL PRODUCTS RECOMMENDS OTHER MANUFACTURERS REQUESTING APPROVAL TO BID THEIR PRODUCT AS AN EQUAL, MUST SUBMIT THEIR REQUEST IN WRITING TEN (10) DAYS PRIOR TO CLOSE OF BIDDING.

- b. Finish/Color: (See 2.06 Finishes)
 - c. Framing Member Profile: 1-3/4" x 4-1/2" nominal dimension; Center Glazed; Screw Spline Fabrication.
Provide combination full height subsill flashing and sill section which eliminate blind seal conditions at fasteners penetrating subsill flashing. Subsill flashing to have full height end dams at each end.
- B. Alternate (Manufacturers/Products): In lieu of providing below specified base bid/contract manufacturer, provide below specified alternate manufacturers. Refer to Division 1 Alternates Section.
1. Base Bid/Contract Manufacturer/Product: Coral Architectural Products
 - a. Product: Architectural Aluminum
 - b. Series FL200 Storefront System: 1-3/4" x 4-1/2" nominal dimension, Center Glazed; Screw-Spline Fabrication
- C. Substitutions:
1. General: Refer to Division 1 Substitutions for procedures and submission requirements.
 - a. Pre-Contract (Bidding Period) Substitutions: Submit written requests ten (10) days prior to bid date.
 - b. Post-Contract (Construction Period) Substitutions: Submit written request in order to avoid storefront installation and construction delays.
 2. Substitution Documentation
 - a. Product Literature and Drawings: Submit product literature and drawings modified to suit specific project requirements and job conditions.
 - b. Certificates: Submit certificate(s) certifying substitute manufacturer, attesting to adherence to specification requirements for storefront system performance criteria.
 - c. Test Reports: Submit test reports verifying compliance with each test requirement for storefront required by the project.
 - d. Product Sample and Finish: Submit product sample, representative of storefront for the project, with specified finish and color.
 3. Substitution Acceptance: Acceptance will be in written form, either as an addendum or modification, and documented by a formal change order signed by the Owner and Contractor.

2.02 Materials

- A. Aluminum (Storefront and Components):
1. Material Standard: Extruded Aluminum, ASTM B 221, 6063-T6 alloy and temper.
 2. Member Wall Thickness: Each framing member shall have a wall thickness sufficient to meet the specified structural requirements.
 3. Tolerances: Reference to tolerances for wall thickness and other cross-sectional dimensions of storefront framing members are nominal and in compliance with Aluminum Association Standards and Data.

2.03 Accessories

- A. Fasteners: Where exposed, shall be Stainless Steel.
- B. Gaskets: Glazing gaskets shall comply with ASTM C 864 and be extruded of silicone compatible EPDM material that provides for silicone adhesion.
- C. Perimeter Anchors: When steel anchors are used, provide insulation between steel material and aluminum material to prevent galvanic action.

GUIDE SPECIFICATION

2.04 Related Materials

- A. Sealants: Refer to Joint Treatment (Sealants) Section.
- B. Glass: Refer to Glass and Glazing Section.

2.05 Fabrication

- A. General:
 - 1. Fabricate components per manufacturer's installation instructions and with minimum clearances and shim spacing around perimeter of assembly, yet enabling installation and dynamic movement of perimeter seal.
 - 2. Accurately fit and secure joints and corners. Make joints flush, hairline and weatherproof.
 - 3. Arrange fasteners and attachments to conceal from view.

EDITOR NOTE: SELECT BELOW FINISH AND COLOR FROM CORAL ARCHITECTURAL PRODUCTS' STANDARD COLORS. CORAL'S POWDER COAT FINISHES ARE HIGH-PERFORMANCE DURABLE FINISHES OFFERING IMPROVED GLOSS RETENTION AND ENHANCED RESISTANCE TO CHALKING AND FADING. CUSTOM COLORS ARE AVAILABLE UPON REQUEST FROM CORAL ARCHITECTURAL PRODUCTS IN A TWO COMPONENT POLYESTER POWDER COAT FINISH CONFORMING TO AAMA 2604 AND (70%) THERMOSETTING FLUOROPOLYMER POWDER COAT FINISH CONFORMING TO AAMA 2605. CONSULT WITH YOUR CORAL SALES OR ARCHITECTURAL REPRESENTATIVE FOR OTHER SURFACE TREATMENTS AND FINISHES.

2.06 Finishes

- A. Shop Finishing
 - 1. Color Anodizing Conforming to AA-M12C22A34, AAMA 611, Architectural Class I. Color Anodic Coating (Color: #20 Dark Bronze) (Standard) or AA-M12C22A44, AAMA 611, Architectural Class I. Color Anodic Coating (Color: #30 Black) (Select).
 - 2. Clear Anodizing Conforming to AA-M12C22A31, AAMA 611, Architectural Class I. Clear Anodic Coating (Clear: #10) (Standard).
 - 3. Two Component Polyester Powder Coating Conforming to AAMA 2604 (Color: _____).
 - 4. (70%) Fluoropolymer Thermosetting Powder Coating Conforming to AAMA 2605 (Color: _____).
 - 5. Other: Manufacturer _____ Type _____ Color: _____).

2.07 Source Quality Control

- A. Source Quality: Provide aluminum storefront specified herein from a single source.
 - 1. Building Enclosure System: When aluminum curtain walls are part of a building enclosure system, including entrances, entrance hardware, windows, curtain wall framing and related products, provide building enclosure system products from a single source manufacturer.

PART 3 – EXECUTION

3.01 Examination

- A. Site Verification of Conditions: Verify substrate conditions (which have been previously installed under other sections) are acceptable for product installation in accordance with manufacturer's instructions. Verify openings are sized to receive specified system and sill plate is level in accordance with manufacturer's acceptable tolerances.

EDITOR NOTE: COORDINATE BELOW ARTICLE WITH MANUFACTURER'S RECOMMENDED INSTALLATION DETAILS AND INSTALLATION INSTRUCTIONS.

- 1. Field Measurements: Verify actual measurements/openings by field measurements before fabrication; show recorded measurements on shop drawings. Coordinate field measurements, fabrication schedule with construction progress to avoid construction delays.

3.02 Installation

- A. General: Install storefront systems plumb, level and true to line, without warp or rack of frames with manufacturer's prescribed tolerances and installation instructions. Provide support and anchor in place.
 - 1. Dissimilar Materials: Provide separation of aluminum materials from sources of corrosion or electrolytic action contact points.

GUIDE SPECIFICATION

2. Glazing: Glass shall be (outside) or (inside) glazed and held in place with extruded EPDM glazing gaskets on both sides of the glass.
 3. Water Drainage: ***Water deflectors shall be installed at each end of intermediate horizontal allowing infiltrated water to drain down the vertical member's glazing pocket into a full height subsill flashing where it weeps to the exterior.***
- B. Related Products Installation Requirements:
1. Sealants (Perimeter): Refer to Division 7 Joint Treatment (Sealants) Section.
 2. Glass: Refer to Division 8 Glass and Glazing Section.
 - a. Reference: ANSI Z97.1, CPSC 16 CFR 1201 and GANA Glazing Manual.

3.03 Field Quality Control

- A. Field Tests: Architect shall select storefront units to be tested as soon as a representative portion of the project has been installed, glazed, perimeter caulked and cured. Conduct tests for air infiltration and water penetration with manufacturer's representative present. Tests not meeting specified performance requirements and units having deficiencies must be corrected as part of the contract amount.
1. Testing: Testing shall be performed per AAMA 503 by a qualified independent testing agency. Refer to Division Testing Section for payment of testing and testing requirements.
 - a. Air Infiltration Tests: Conduct tests in accordance with ASTM E 783. Allowable air infiltration shall not exceed 1.5 times the amount indicated in the performance requirements or 0.09 cfm/ft², which, ever is greater.
 - b. Water Infiltration Tests: Conduct tests in accordance with ASTM E 1105. No uncontrolled water leakage is permitted when tested at a static test pressure of two-thirds the specified water penetration pressure but not less than 8 PSF.
- B. Manufacturer's Field Services: Upon Owner's request, provide manufacturer's field service consisting of product use recommendations and periodic site visit for inspection of product installation in accordance with manufacturer's instructions.

3.04 Protection and Cleaning

- A. Protection: Protect installed product's finish surfaces from damage during construction. Protect aluminum storefront system from damage from grinding and polishing compounds, plaster, lime, acid, cement or other harmful contaminants.
- B. Cleaning: Repair or replace damaged installed products. Installed products are to be cleaned in accordance with manufacturer's instructions prior to owner's acceptance. Remove construction debris from project site and legally dispose of debris.

DISCLAIMER STATEMENT

This guide specification is intended for use by a qualified construction specifier. The guide specification is not intended to be verbatim as a project specification without appropriate modifications for the specific use intended. The guide specification must be used and coordinated with the procedures of each design firm and the particular requirements of a specific construction project.

END OF SECTION 08410

FL200·1¾" x 4½"

Non-Thermal Storefront

FEATURES AND BENEFITS

System Description

Series FL200 non-thermal 1 ¾" x 4 ½" center set storefront framing system for ¼" or ⅜" glass is designed for low-rise applications. Snap-together profiles using integral screw-spline joinery allows for the frames to be pre-assembled in panels resulting in increased productivity and quality control. Perimeter profiles with full-depth pockets eliminate the need for filler plates and provide direct anchoring to the substrate with excellent water control.

Features

- Outside or Inside Glazed
- Screws-spline Assembly
- Accepts ¼" or ⅜" Glazing Infill
- CoraPunch Punch Press Die Sets or Drill Jigs Available
- Deep Glazing Pocket Profiles eliminates blind seal conditions at sill and installation of filler plates at head and wall jambs
- Sill Flashing with Full-height Interior Leg and Integral "C" Slot for Continuous Line of Sealant
- Fully Tested

Performance Test Standards

- ASTM E 283 – Air Infiltration Test
- ASTM E 331 – Water Infiltration Test
- ASTM E 330 – Uniform Load Deflection and Structural Test
- Florida Product Approval Number – FL8832 (non-impact for use outside HVHZ)

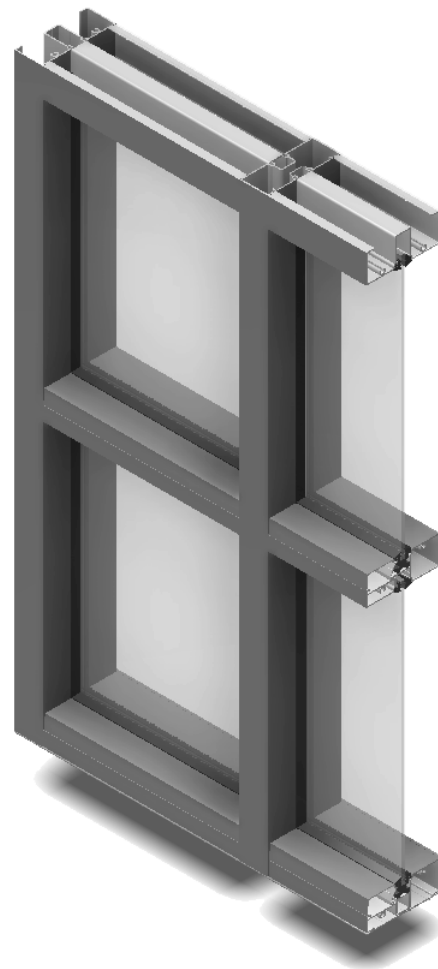

Standard Framing
Scale: 3" = 1'-0"

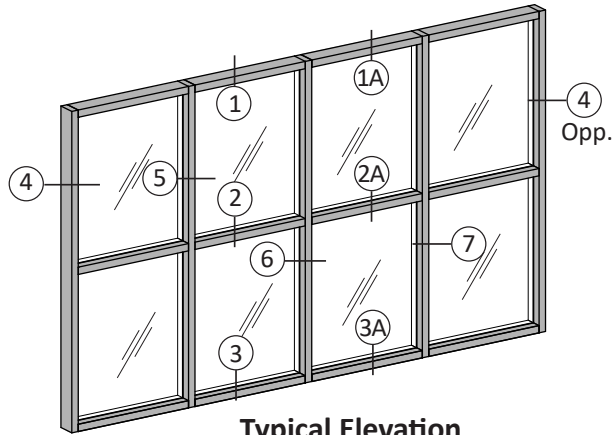

Typical Elevation

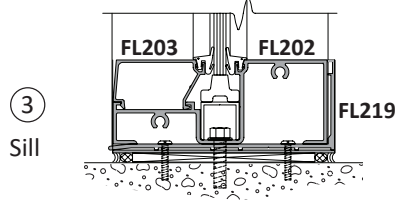
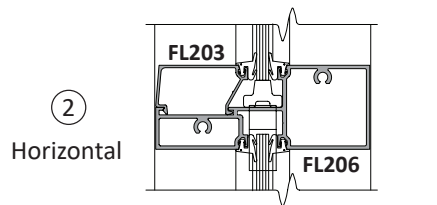
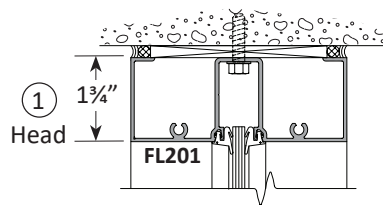
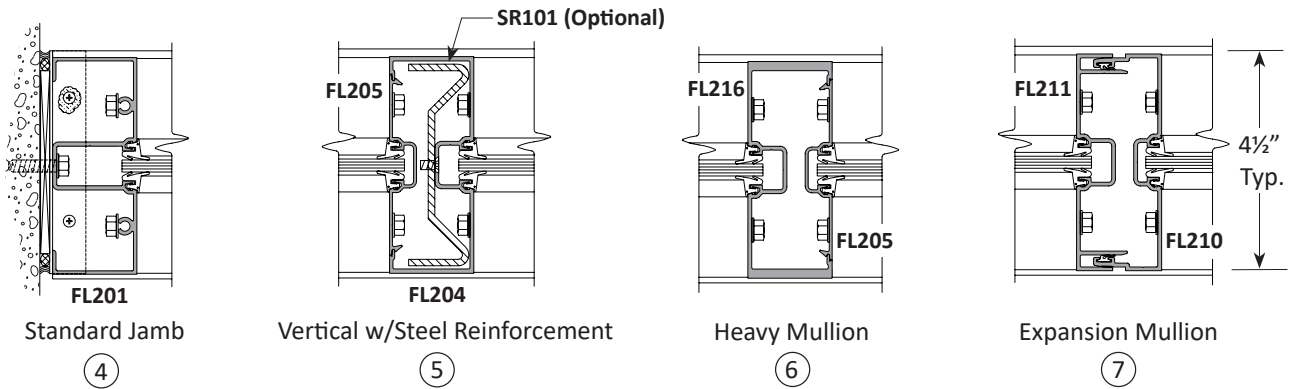

Exterior Glazing

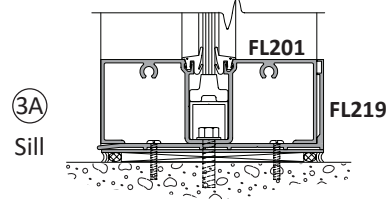
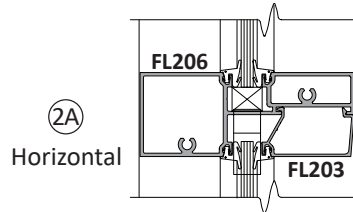
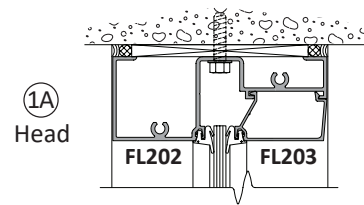

Interior Glazing

FL200·1³/₄"x4¹/₂"

Non-Thermal Storefront

Optional Framing
Scale: 3" = 1'-0"

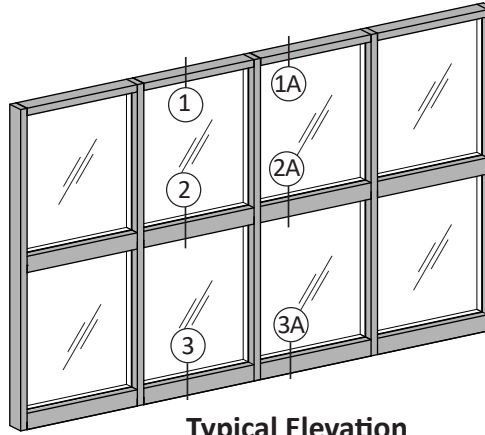

Typical Elevation

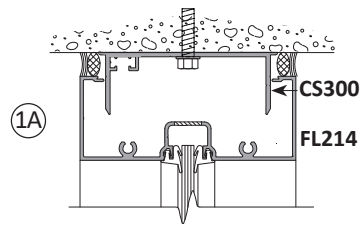
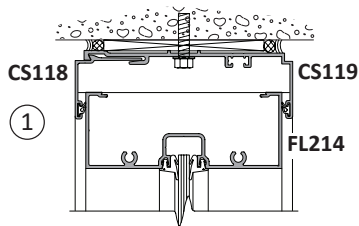

Optional Head Members

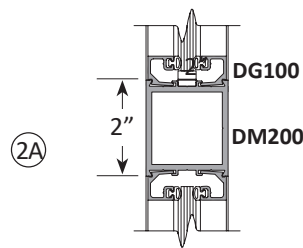
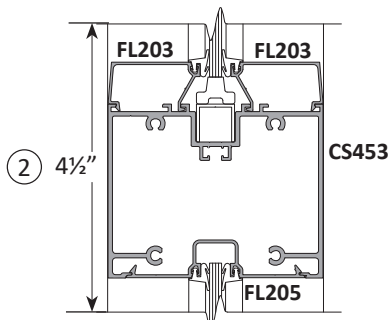

Optional Horizontal Members

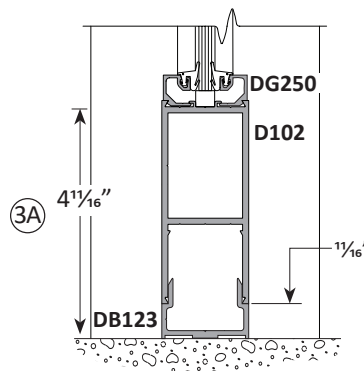
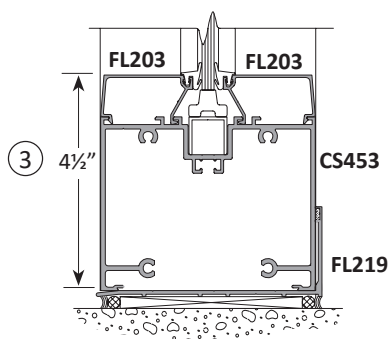

Optional Sill Members

Optional Framing
Scale: 3" = 1'-0"

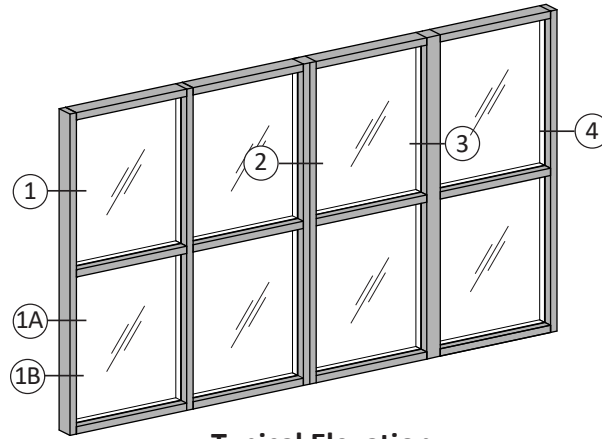

Typical Elevation

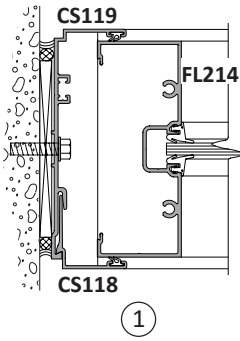

1

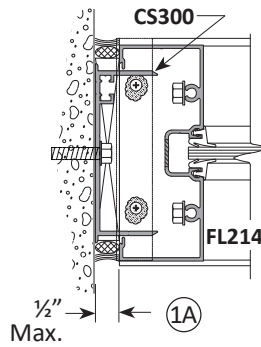

1A

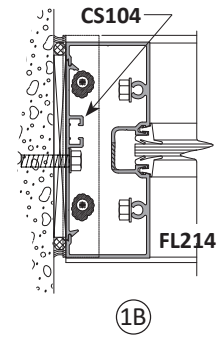

1B

Optional Jamb Members

Note: 0.125" Aluminum Brake Metal by others (typical)

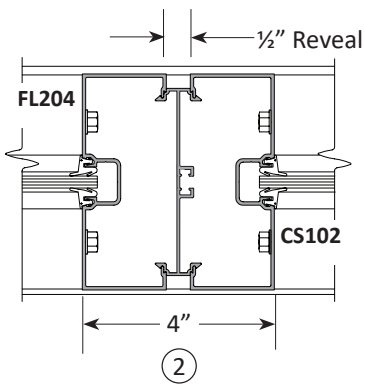

2

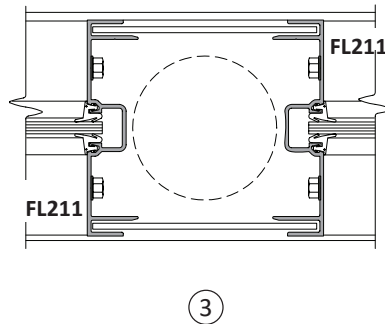

3

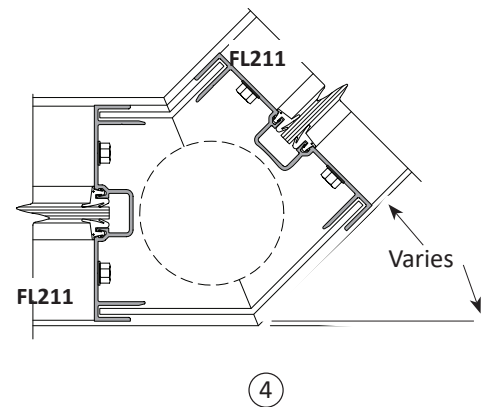

4

Optional 4" Vertical and Post Corners

FL200·1³/₄"x4¹/₂"

Non-Thermal Storefront

Corner Framing
Scale: 3" = 1'-0"

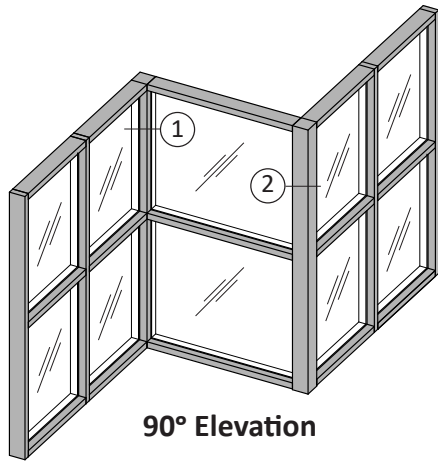

90° Elevation

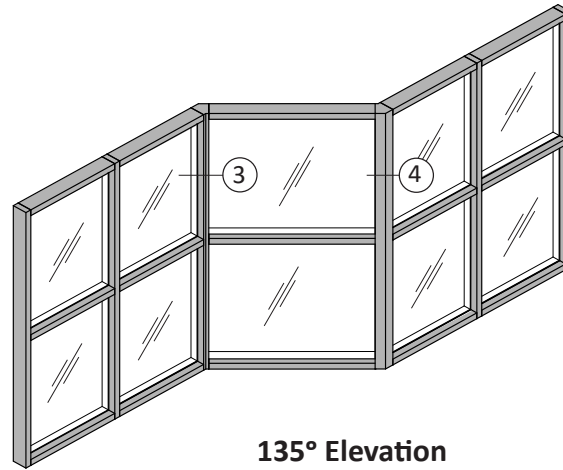

135° Elevation

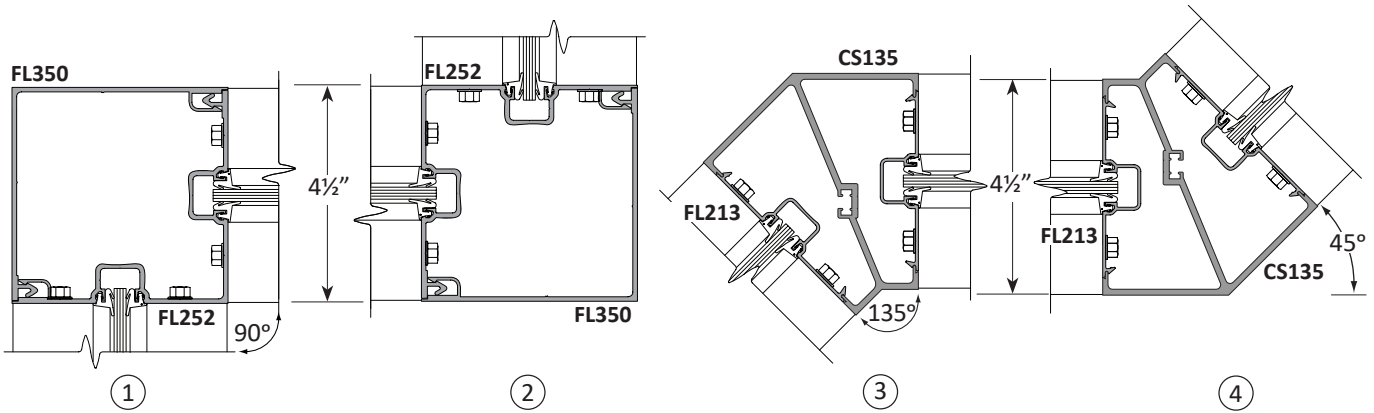

90° and 135° Corner Conditions

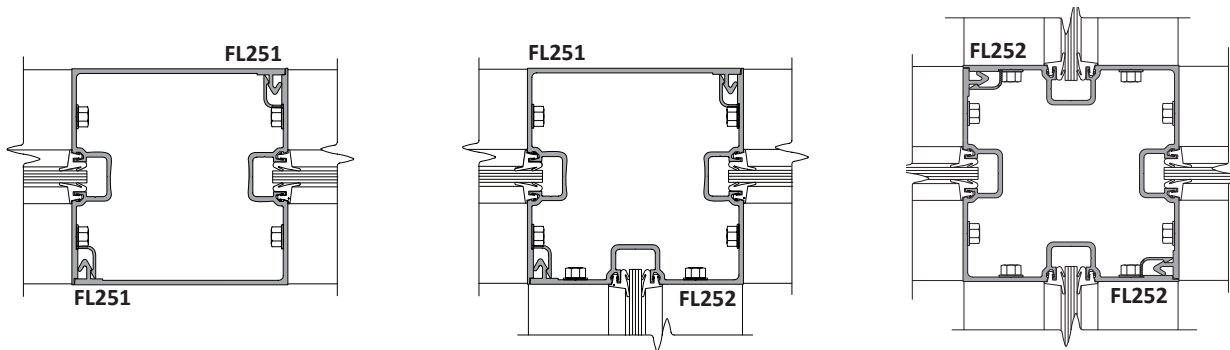

Optional Corner Post Conditions

Entrance Framing - Non-Transom
Scale: 3" = 1'-0"

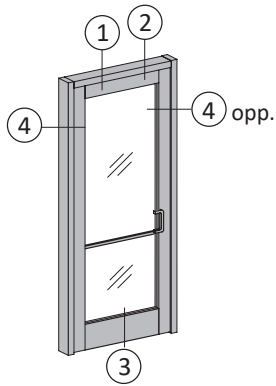

Single Acting Doors
Non-Transom Frame

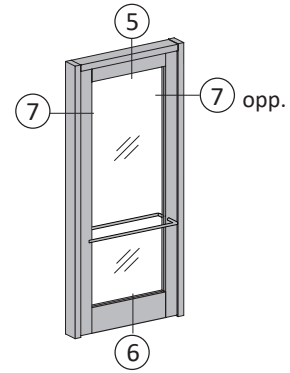

Double Acting Doors
Non-Transom Frame

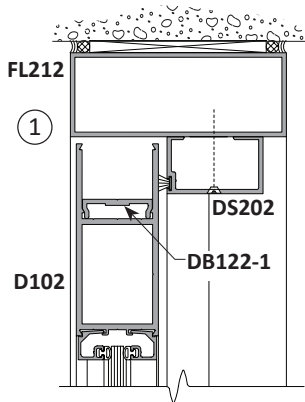

Concealed Overhead Closer

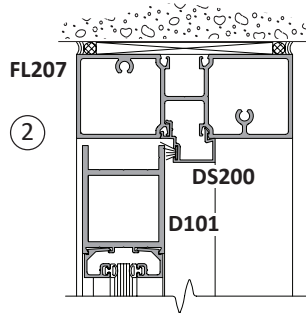

Surface Mounted Closer

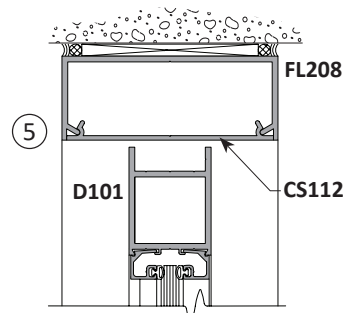

Concealed Overhead Closer

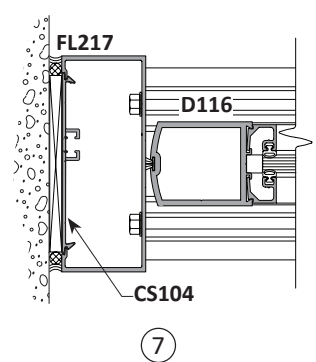
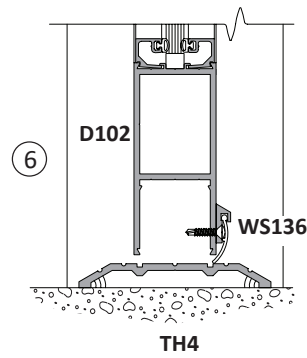
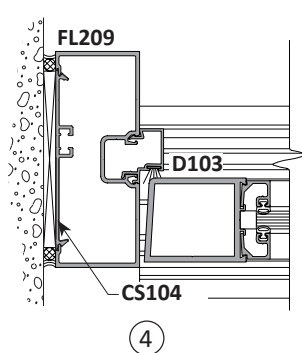
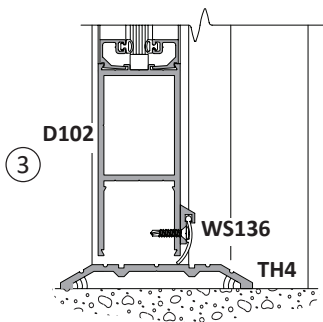

FL200·1³/₄"x4¹/₂"

Non-Thermal Storefront

Entrance Framing - Single Acting with Transom
Scale: 3" = 1'-0"

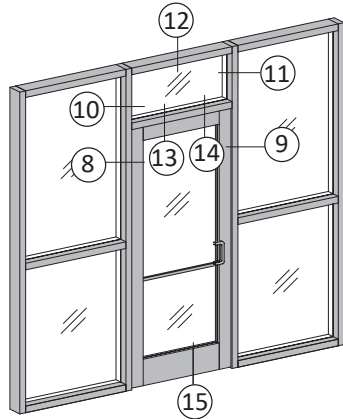

**Single Acting Doors
with Transom Frame**

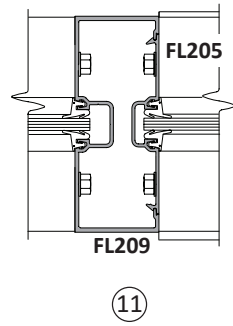
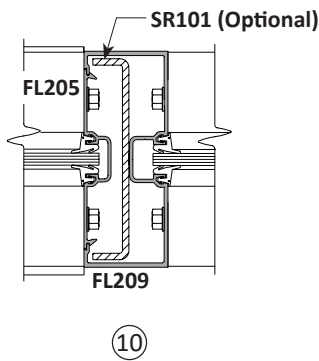
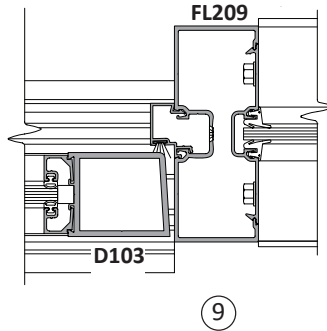
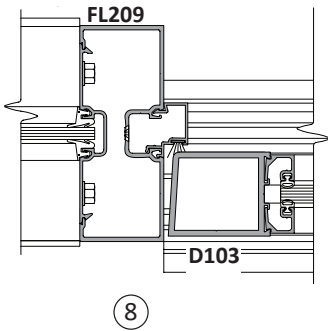
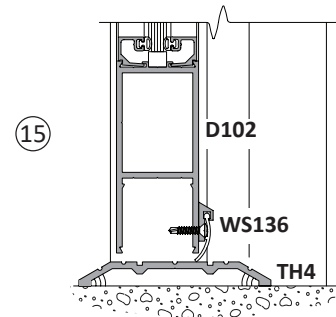
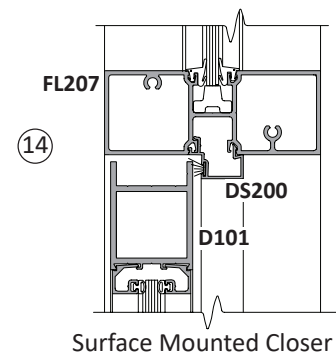
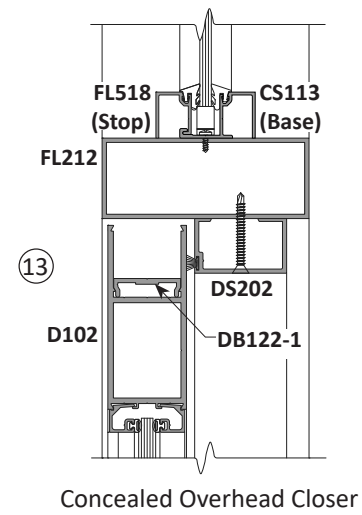
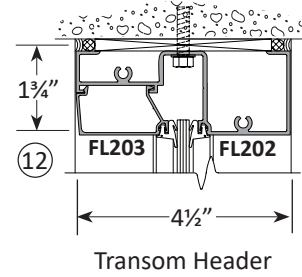

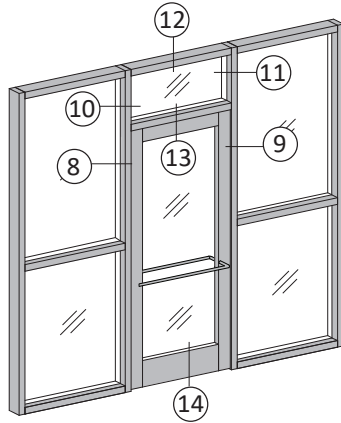

**Double Acting Doors
with Transom Frame**

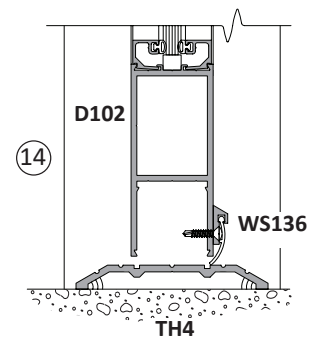
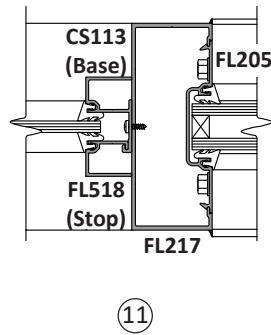
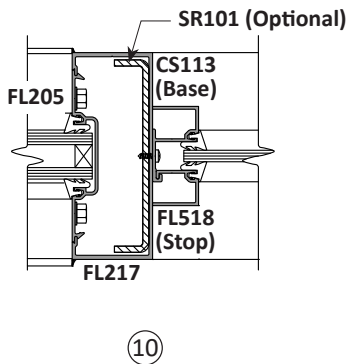
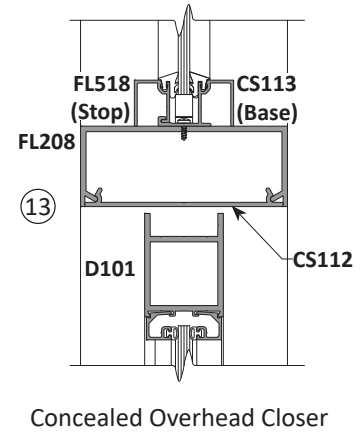
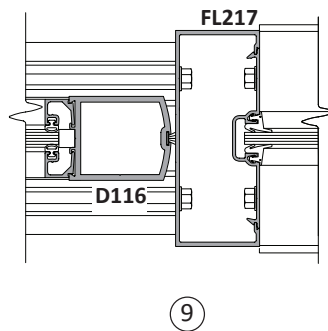
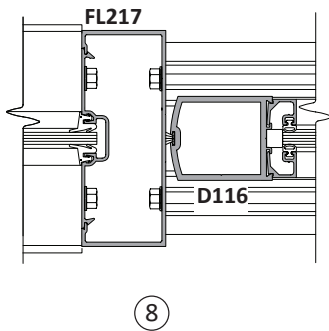
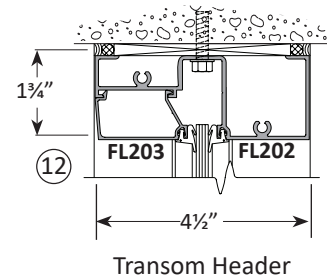

FL200·1³/₄"x4¹/₂"

Non-Thermal Storefront



Wind Load Charts

Mullions are designed for L/175 deflection ratio and the allowable working stresses for wind load shown below:

Aluminum Alloy 6063 - T6 = 25 ksi / 1.65 = 15.15 ksi

Steel Reinforcing: 36 ksi x 0.67 = 24 ksi

Limitations of Vertical Mullions for Curves

A	20 PSF	E	40 PSF
B	25 PSF	F	45 PSF
C	30 PSF	G	50 PSF
D	35 PSF	H	60 PSF

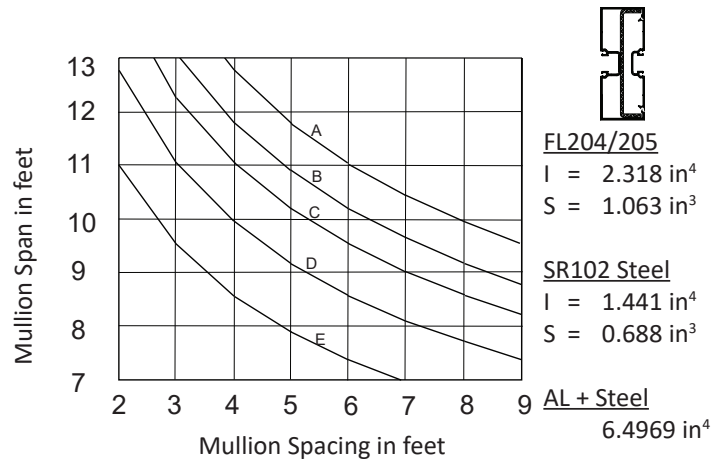
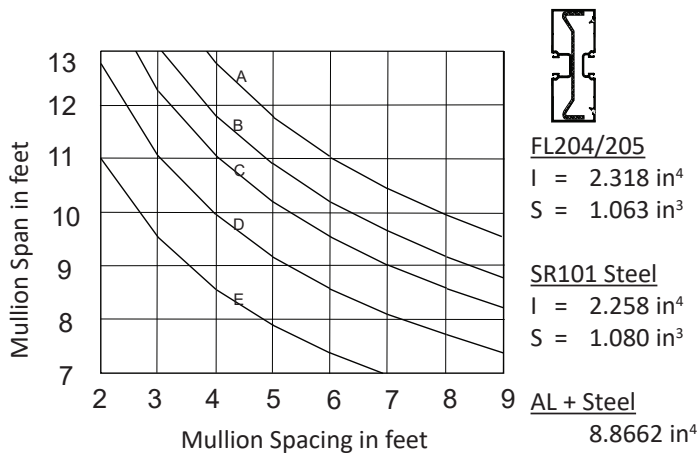
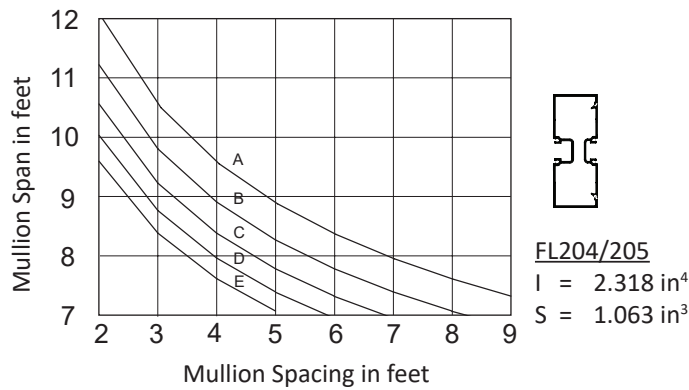

Mullions are designed for L/175 deflection ratio and the allowable working stresses for wind load shown below:

Aluminum Alloy 6063 - T6 = 25 ksi / 1.65 = 15.15 ksi

Steel Reinforcing: 36 ksi x 0.67 = 24 ksi

Limitations of Vertical Mullions for Curves

A	20 PSF	E	40 PSF
B	25 PSF	F	45 PSF
C	30 PSF	G	50 PSF
D	35 PSF	H	60 PSF

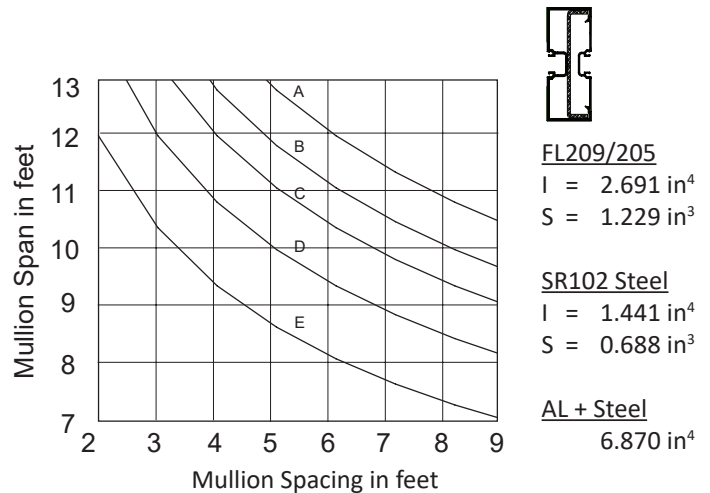
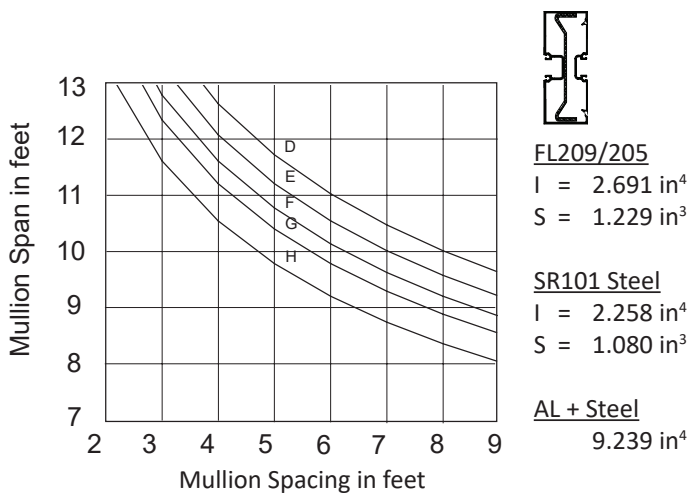
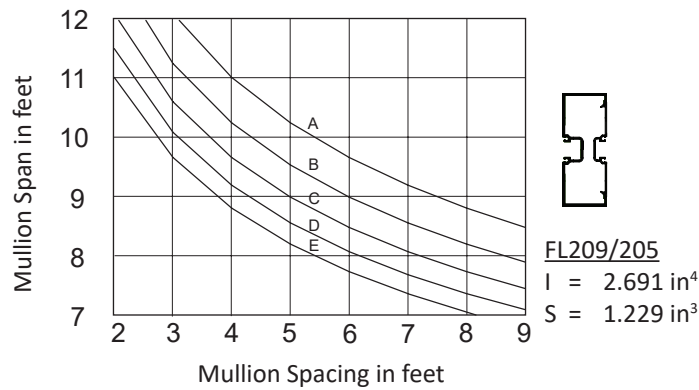

FL200·1³/₄"x4¹/₂"

Non-Thermal Storefront



Wind Load Charts and Dead Load Charts

Mullions are designed for L/175 deflection ratio and the allowable working stresses for wind load shown below:

Aluminum Alloy 6063 - T6 = 25 ksi / 1.65 = 15.15 ksi

Steel Reinforcing: 36 ksi x 0.67 = 24 ksi

Limitations of Vertical Mullions for Curves

A	20 PSF	E	40 PSF
B	25 PSF	F	45 PSF
C	30 PSF	G	50 PSF
D	35 PSF	H	60 PSF

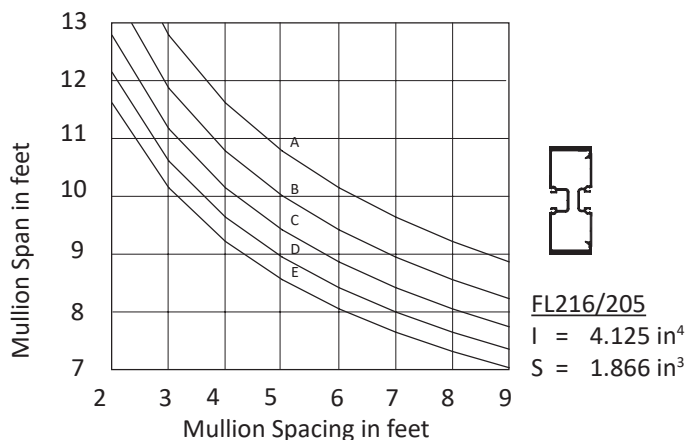
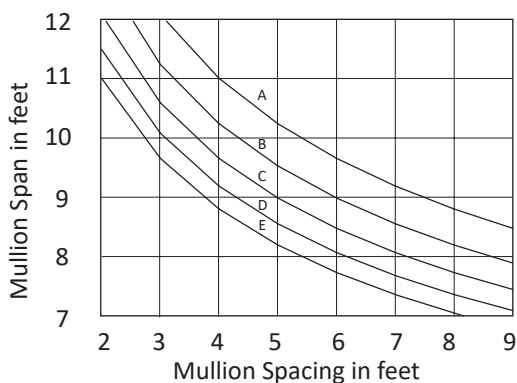

DEAD LOAD CHARTS

INTERMEDIATE HORIZONTAL

Dead load charts are based on 1/8' maximum allowable deflection at the center point of the horizontal member and on a theoretical glass weight of 3.25 P.S.F.

Glass shall rest on two setting blocks located at:

CURVE A = 1/4 points

CURVE B = 1/8 points or 8" from corners, whichever is larger

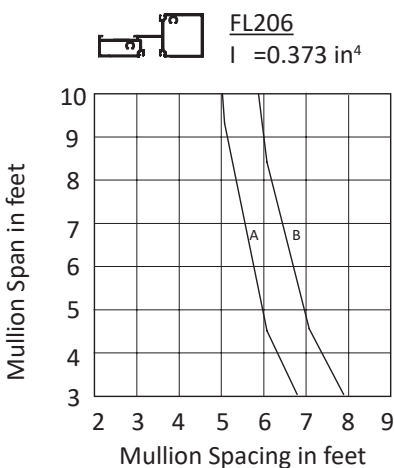

DOOR HEADERS

Dead load charts for door headers are based on 1/16" maximum deflection at the center point of the header and on a theoretical glass weight of 3.25 P.S.F.

CURVE A = 1/4 points

CURVE B = 1/8 points or 8" from corners, whichever is larger

