

## High Velocity Hurricane Zone (HVHZ) Applications

### Series 281 Narrow Stile Impact-Resistant Entrances (Wet-Glazed)

#### Qualified System Configuration Chart

Design Pressure P.S.F.	Maximum Door Size		Maximum Glass Size		Qualified Glass Types
	Single	Double	D.L.O. (WxH)	Sq. Ft.	
Series 281 Narrow Stile - Large Missile					
+65/-65	36 x 84	72 x 84	29 $\frac{5}{16}$ " x 71 $\frac{7}{16}$ "	14.7	B

#### Hurricane Impact-Resistant Products Disclaimer Note

Coral's hurricane impact-resistant products meet a variety of test standards for applications in coastal construction regions satisfying the demands for wind-borne debris hazards and high-velocity winds associated with hurricanes. All of Coral's hurricane impact-resistant products are independent laboratory tested based on a variety of test standards for air infiltration, structural loads, missile impact and air-pressure cycling based on ASTM and/or Florida Building Code. The informational chart above is intended to provide recommended limits in frame heights, glass sizes and design pressures based on product testing. When exceeding conditions listed above, it is recommended to consult with a licensed structural engineer or contact Coral Architectural Products.

#### Hardware Applications

Locking and Closer Options		
Active Leaf	DH072 3-Point Lock with DH078 Cylinder and DH079 Thumbturn	
Inactive Leaf	DH176 Steel Tip Flush Bolts (2 each)	
Surface Applied Closer	Heavy Duty ANSI Grade 1 (Required)	
Concealed Overhead Closer	ANSI Grade 1 (Required)	
Hinging Options		
Type	Description	Quantity
Butt Hinges	DH110SS (Stainless Steel) 4 $\frac{1}{2}$ " x 4"	1 $\frac{1}{2}$ Pairs
Continuous Geared Hinge	DH111HD (Heavy Duty)	Full Door Height
Panic Exit Devices Options		
Jackson	2086-HR ANSI Grade 1	Concealed Vertical Rod

#### Qualified Glass Types

Glass Type	Glass Composition			Interlayer Manufacturer	Glass Identification
	Exterior Lite	Interlayer	Interior Lite		
$\frac{5}{16}$ " Monolithic Glass	$\frac{1}{4}$ " Heat Strengthened Glass	.090 Saflex PVB Interlayer	$\frac{1}{4}$ " Heat Strengthened Glass	Solutia	B

# Impact-Resistant Entrances

## Series 281 Narrow Stile

### Hardware and Hinge Locations

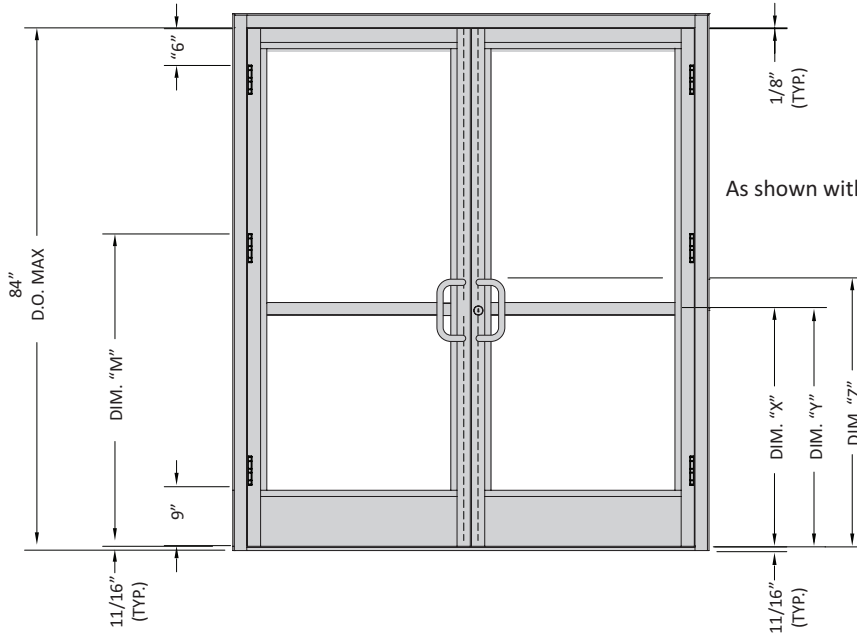

As shown with Panice Device.

INTERMEDIATE HINGE	
D.O. HEIGHT	DIM. "M"
	BUTT HUNG
84"	45 <sup>11</sup> / <sub>32</sub> "

**Note:** All doors require an intermediate hinge.

HARDWARE LOCATIONS FOR PANIC DOORS				
MANUFACTURER	PANIC DEVICE	DIM "X" ☉ OF CYLINDER	DIM "Y" ☉ OF PANIC	DIM "Z" TOP OF PULL
JACKSON	2086 C.V.R.	37 <sup>7</sup> / <sub>8</sub> "	38 <sup>5</sup> / <sub>32</sub> "	42 <sup>7</sup> / <sub>8</sub> "

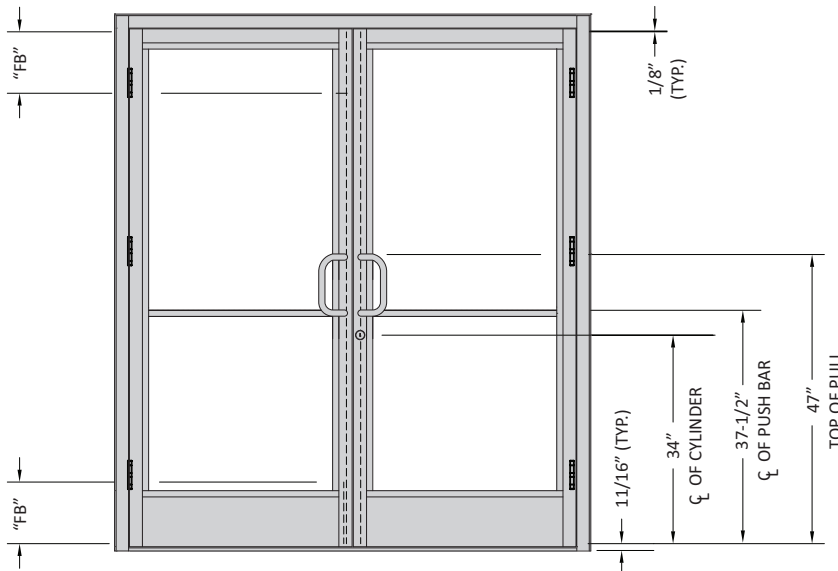

# Impact-Resistant Entrances

## Series 281 Narrow Stile

Standard Details - Single Acting  
 Scale: 3" = 1'-0"



Single Door

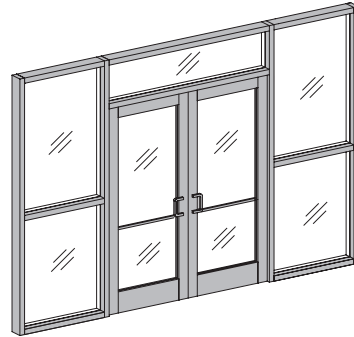

Pair of Doors

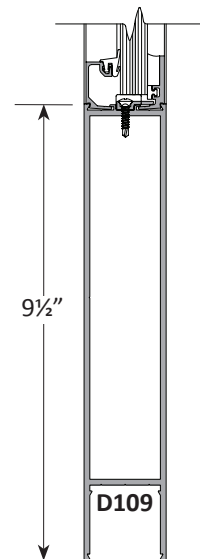
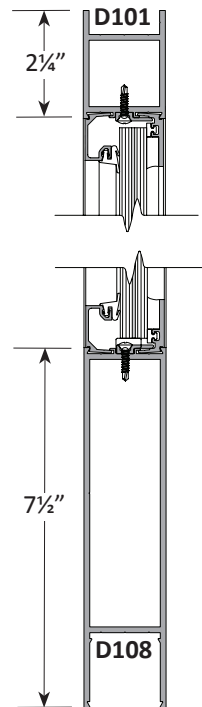
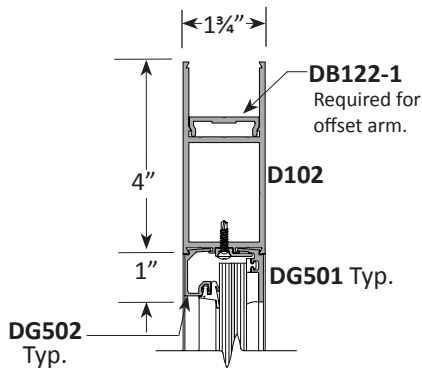
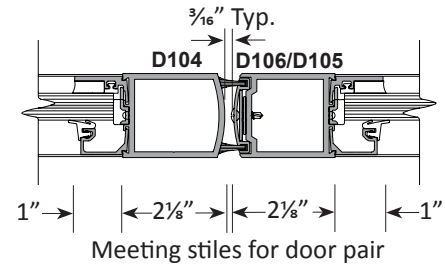
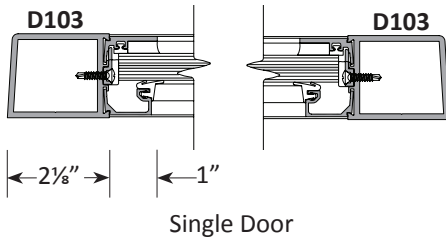

# Impact-Resistant Entrances

## Series 281 Narrow Stile

### Entrance Framing - Single Acting Non-Transom

Scale: 3" = 1'-0"

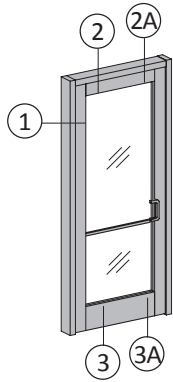

**Single Acting Doors  
Non-Transom Frame**

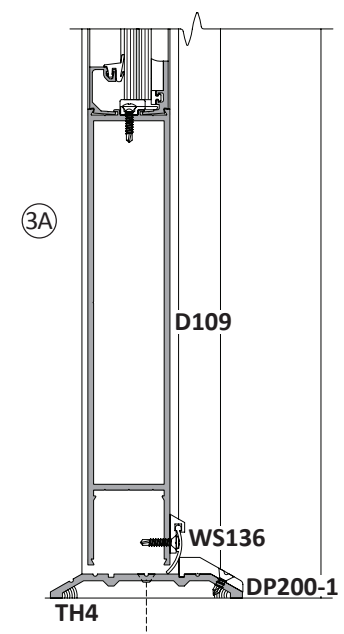
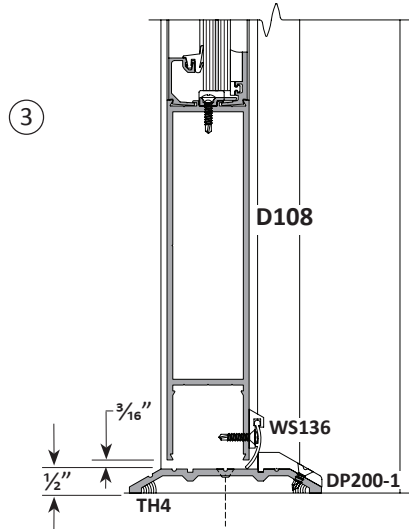
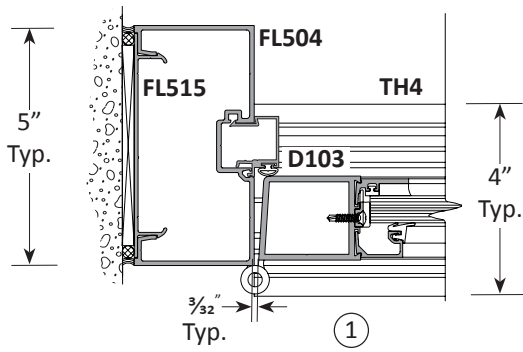
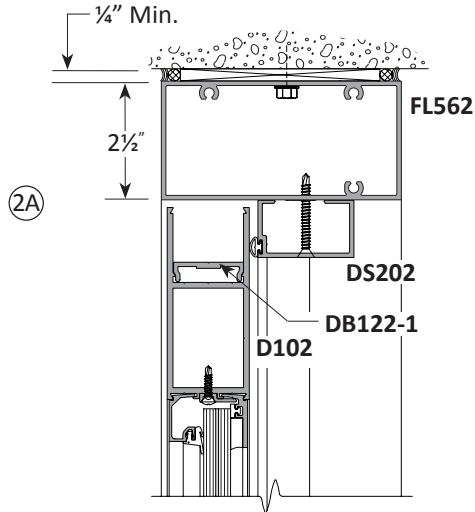
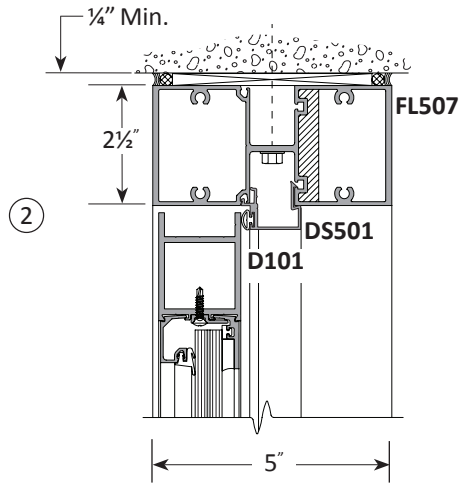

Entrance Framing - Single Acting with Transom  
Scale: 3" = 1'-0"

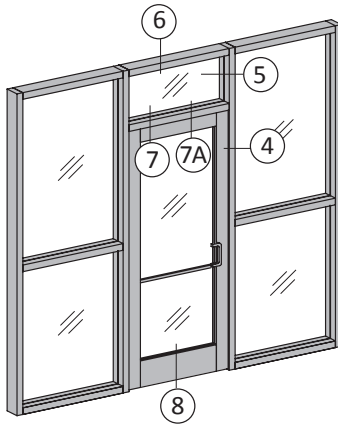

Single Acting Doors  
with Transom Frame

