

Architectural Products Pricing Guide

Table of Contents

General Information.....	GI
Section A - Entrances.....	A
Entrances.....	A1
Adds, Substitutions and Modifications.....	A2
Loose Hardware.....	A3
Section B - Storefronts.....	B
FL200 Storefront System.....	B1
FL300 Storefront System.....	B2
FL300T Thermal Storefront System.....	B3
FS400T Thermal Storefront System.....	B4
Angles, Channels, Flat Bars, & Tubes.....	B5
FL100 Removable Office Partition.....	B6
FL600 Storefront System.....	B7
FL600T Thermal Storefront System.....	B8
FL600UT Thermal Storefront System.....	B9
Section C - Curtain Walls.....	C
PW251 Curtain Wall System.....	C1
Section D - Impact-Resistant Entrances.....	D
Impact Doors and Frames.....	D1
Adds, Substitutions and Modifications.....	D2
Section E - Impact-Resistant Storefronts.....	E
FL500 Impact-Resistant Storefront System.....	E1
FL550 Impact-Resistant Storefront System.....	E2
FL550T Thermal Impact-Resistant Storefront System.....	E3
Section F - Impact-Resistant Curtain Walls.....	F
PW256 Impact-Resistant Curtain Wall.....	F1
PW257 Impact-Resistant Curtain Wall.....	F2

Page Left Intentionally Blank

Table of Contents

	<i>Page</i>
Company Profile	1
Architectural Finishes	2-4
Warranties	5-11
Terms and Conditions	12-13

Page Left Intentionally Blank

Coral Industries, Inc.



L.L. "Mac" McAllister, Jr.
Chief Executive Officer

Albert E. Askew
President

Lewis L. McAllister, III
Executive Vice President

D. Grant McAllister
Executive Vice President and
Chief Financial Officer

The Company

Coral Industries, Inc. was established in 1976 as a manufacturer of quality bath enclosures. Today Coral Industries is the largest independent manufacturer in an industry including nearly 150 national and regional competitors. Our past growth can be contributed to the result of customer's success utilizing the many advantages Coral Industries offer: quality, service, innovative design and dependability. At Coral's 325,000 square feet manufacturing facility located in Tuscaloosa, Alabama, in-house capabilities include injection molding of plastic parts, soft and rigid vinyl extrusions, powder coat painted finishing, and complete fabrication of aluminum profiles and glass products, thus giving Coral Industries greater flexibility and control of the entire production process.

Over the years, Coral Industries has expanded by organizing additional divisions and products. **Central Alabama Transport (CAT)** was founded in 1977 and has proven to be a valuable addition to Coral Industries. CAT is a dedicated fleet of trucks which allows for our products to be delivered on a timely basis to distribution centers and businesses across the United States. **Coral Glass Division**, established in 1989, offers a full range of custom fabricated glass, ranging from 1/8" to 1", in addition to laminated and custom insulated glass. Coral Glass Division has an assortment of computer operated cutting, fabrication, and tempering machinery that allows for the fabrication of glass to exacting tolerances.

Coral Architectural Products

In keeping with Coral Industries tradition of growth, **Coral Architectural Products (CAP)** was established in January 2005. CAP offers a full line of architectural aluminum entrance doors, storefronts, curtain walls, window walls and protective glazing products. To ensure structural integrity and performance requirements for today's demanding projects; all of our architectural products are tested to current AAMA and / or ASTM performance standards for structural, air and water infiltration at certified independent test laboratories. We have also designed and tested products that meet the stringent requirements of both High Velocity Hurricane Impact Zones and Blast Mitigation. Comprehensive architectural details, installation instructions and test reports are available for each system.

The Product Line

CAP has combined the experience of its management team with over 35 years of designing, testing and marketing in the industry in order to develop **its industry leading** aluminum systems. Each system is designed and tested for simplicity, versatility, maximum performance and ease of installation.

Mission Statement

Coral Industries, Inc. is dedicated to the continuous improvement of the quality of our products, processes and services in order to exceed our customer's expectations.

Coral Architectural Products offers a variety of architectural finishes satisfying the increased demands of the commercial construction industry in terms of finish types and performance, while protecting the environment. Standard finishes include, but are not limited to the following types: anodized finishes, factory applied powder coat and special baked-on liquid painted finishes. Consult with your local Coral sales representative or Coral’s national architectural representative at 1-800-772-7737 for additional surface treatments and options.

Anodized Finishes

Anodic, or anodized, finishes for architectural aluminum profiles are artificially enhanced by a natural process in which aluminum combines with oxygen to form a thin layer of aluminum oxide. The result is an extremely durable finish offering excellent resistance to weathering and corrosion.

ANODIZING FINISH CLASSIFICATION / CODE IDENTIFICATION				
Coral Number	Color	Aluminum Association Specification	Classification	Stock
CLEAR ANODIZED FINISHES				
#10	Clear	AA-M12-C22-A31	Architectural Class II (.4 mils minimum)	Yes
#11	Clear	AA-M12-C22-A41	Architectural Class I (.7 mils minimum)	Yes
COLOR ANODIZED FINISHES				
#20	Dark Bronze	AA-M12-C22-A34	Architectural Class II (.4 mils minimum)	Yes
#21	Dark Bronze	AA-M12-C22-A44	Architectural Class I (.7 mils minimum)	* No

* Contact us for lead time.

Powder Coat Painted Finishes

Powder Coat Finishes are high-performance durable architectural finishes offering improved gloss retention and enhanced resistance to chalking and fading. Environmentally friendly, powder coat finishes are solvent-free and provide outstanding mechanical properties and abrasion resistance over solvent based paints. Coral Architectural Products powder coat finishes are available in two levels of performance listed below.

NOTE: Contact the Coral factory for information on custom colors and non-stock finishes.

AAMA 2604

POWDER COAT CLASSIFICATION/CODE IDENTIFICATION				
Coral Number	Color	American Architectural Manufacturers Association (AAMA) Specification	Classification	Stock
FINISHES				
#81	Bone White	AAMA 2604	Polyester	Yes
#92	Light Blue	AAMA 2604	Polyester	Yes
#93	Hartford Green	AAMA 2604	Polyester	Yes
#94	Tan	AAMA 2604	Polyester	Yes
#95	Coal Black	AAMA 2604	Polyester	Yes
#96	Sandstone	AAMA 2604	Polyester	Yes
#97	Seawolf	AAMA 2604	Polyester	Yes
#98	Redwood	AAMA 2604	Polyester	Yes

AAMA 2605

POWDER COAT CLASSIFICATION/CODE IDENTIFICATION				
Coral Number	Color	American Architectural Manufacturers Association (AAMA) Specification	Classification	Stock
FINISHES				
#91	Bone White	AAMA 2605	70% Fluoropolymer	Yes
#82	Light Blue	AAMA 2605	70% Fluoropolymer	Yes
#83	Hartford Green	AAMA 2605	70% Fluoropolymer	Yes
#84	Tan	AAMA 2605	70% Fluoropolymer	Yes
#85	Coal Black	AAMA 2605	70% Fluoropolymer	Yes
#86	Sandstone	AAMA 2605	70% Fluoropolymer	Yes
#87	Seawolf	AAMA 2605	70% Fluoropolymer	Yes
#88	Redwood	AAMA 2605	70% Fluoropolymer	Yes

PAINTED FINISHES - SPECIFICATIONS

AAMA 2604 – Voluntary Specification, Performance Requirements and Test Procedures for High Performance Organic Coatings on Aluminum Extrusion and Panels. This specification will assist the architect, owner and contractor to specify and obtain factory-applied organic coatings that meet a five-year level of performance in terms of film integrity, weatherability and general appearance.

AAMA 2605 – Voluntary Specification, Performance Requirements and Test Procedures for High Performance Organic Coatings on Aluminum Extrusion and Panels. This specification will assist the architect, owner and contractor to specify and obtain factory-applied organic coatings that meet a ten-year level of performance in terms of film integrity, weatherability and general appearance.

Coral Number	AAMA 2604	AAMA 2605
Coating Thickness	1.2 mils	1.2 mils
Pre-treatment	Multi-stage Cleaning with Chemical Conversion Coating	Multi-stage Cleaning with Chrome Phosphate Conversion Coating 40 mg./ft ² min.
Abrasion Resistance	Falling Stand Test - 20L/mil	Falling Stand Test - 50L/mil
Chemical Resistance	Muriatic Acid/Mortar Resistance/Nitric Acid Flumes Test	Muriatic Acid/Mortar Resistnace/Nitric Acid Flumes Test
Color Retention	5 Year South Florida (Max. Δ E)	10 Year South Florida (Max. Δ E)
Gloss Retention	Minimum of 30% after 5 Years South Florida	Minimum of 50% after 5 Years South Florida
Corrosion Resistance	3000 Hour Salt Spray Test	4000 Hour Salt Spray Test
Chalking Resistance	No more than #8	No More than #8 (#6 for White Colors)
Film Adhesion	Dry Adhesion/Wet Adhesion Boiling Water Adhesion	Dry Adhesion/Wet Adhesion Boiling Water Adhesion

* Contact the Coral factory for availability and lead times on non-stock finishes.

Limited Product Warranty and Remedy

Customer: _____

Project: _____

Effective Date: _____

Architectural Firm: _____

The Seller warrants, for a period of two (2) years from the date of substantial completion of the project provided however that the Limited Warranty shall begin in no event later than six months from date of initial shipment, that the products manufactured by the Seller shall be free from defects in workmanship and materials, provided that such products have been installed and maintained in strict accordance with all applicable safety and building codes, any and all other applicable standards, and Seller's installation instructions. This warranty is limited to defects discovered or which should be discovered within two years from the date of initial shipment provided that the Seller receives written notification specifying any and all defects within that two-year period. Seller's obligations under this warranty are limited to the repair or replacement of any defective materials and/or the refund by the Seller of the original purchase price paid for the product. The Seller reserves the exclusive right to select one of these remedies. In no event will the Seller be liable for direct, indirect, special or consequential damages including but not limited to loss of profits or use.

SELLER MAKES NO WARRANTY OTHER THAN THAT SET FORTH HERE. ALL OTHER EXPRESS AND IMPLIED WARRANTIES ARE HEREBY EXPRESSLY DISCLAIMED, DENIED AND EXCLUDED. SELLER MAKES NO WARRANTY OF MERCHANTABILITY OR THAT THE GOODS ARE FIT FOR ANY PARTICULAR PURPOSE. SELLER MAKES NO REPRESENTATION AS TO THE PRODUCT'S FITNESS FOR ANY PARTICULAR PURPOSE.

Warranty of Outside Suppliers – Seller makes no warranty, and hereby disclaims any and all express warranties, including but not limited to any warranty of merchantability or fitness for a particular purpose, for any products supplied by Seller, which are manufactured by others. Any warranty of such products is limited to that provided by the manufacturer of those products. The Seller will not assume charges for freight or labor for items manufactured by others and supplied by Seller.

Coral Architectural Products

Representative

Customer Service Manager
Title

To Be Advised
Date

SAMPLE WARRANTIES

Door Corner Construction

Limited Lifetime Warranty

Customer: _____

Project: _____

Effective Date: _____

Architectural Firm: _____

This Warranty is in addition to Coral Architectural Products (Seller) standard two (2) years limited warranty and is wholly and exclusively applicable to Seller's factory fabricated and assembled aluminum entrance door's dual moment corner construction.

The Seller warrants to its dealers, customers, and all subsequent purchasers and users that its dual moment corner construction assembly shall be free from defects in workmanship and materials for the normal and useful lifetime of the door.

This warranty is effective from the date of substantial completion of the project provided however that the Limited Warranty shall begin in no event later than 6 months from date of initial shipment from Seller's factory and applies only if Seller's doors have been installed and maintained in strict accordance with Seller's published recommended practices and installation instructions and only if Seller is notified in writing within sixty (60) days after such defects appear.

Seller's obligations under this warranty are limited to the repair or replacement of any defective door and/or the refund by the Seller of the original purchase price paid for the door and does not include the replacement of glazing in-fills, gaskets, hardware, doorframe or adjacent framing temporary enclosures, nor any installation charges, labor charges, delivery or freight charges. The Seller reserves the exclusive right to select one of these remedies.

Seller hereby disclaims all Liability for any door that has been subjected to abuse, alterations, modifications, neglect, misuse, abnormal use, accident, fire, war, flood, earthquakes, Acts of God or damage caused by parts not furnished by Seller.

In no event will the Seller be liable for Direct, Indirect, Special or Consequential Damages including, but not limited to, Loss of Profits or Good Will, Loss of Use or Other Commercial Loss or Injury. Seller further hereby disclaims all liability for the installation of Seller's doors. Seller makes no other Representations or Warranties, Express or Implied, including but not limited to any Implied Warranty of Merchantability or Fitness for a Particular Purpose.

Warranty claim may be filed by notifying Seller in writing within sixty (60) days of defect discovery at:

Warranty Claim Office
 Coral Architectural Products
 P.O. Box 40228
 Tuscaloosa, AL 35404-0228

Coral Architectural Products

 Representative

 Customer Service Manager
 Title

 To Be Advised
 Date

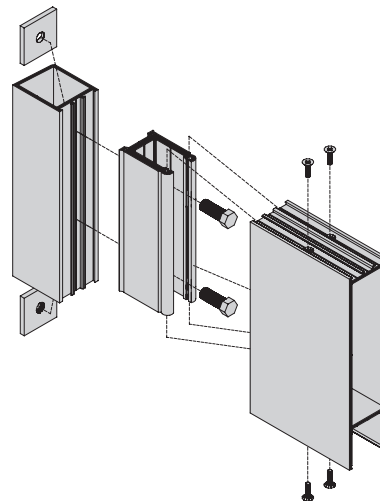

Anodized Finish Limited Warranty

Customer: _____

Project: _____

Architectural Firm: _____

This warranty is in addition to the Coral Architectural Product's standard product warranty.

Coral Architectural Products ("CAP") warrants for a period of two (2) years, from the from the date of substantial completion of the project provided however that the Limited Warranty shall begin in no event later than six months from date of initial shipment, materials from CAP's plant, that all exposed aluminum on the above project furnished by CAP shall conform to the following:

The said aluminum will not develop excessive fading or excessive non-uniformity of color, and will not crack, peel, pit or corrode, all within the limits defined as follows:

"Excessive fading" means that all change in color during the period of this warranty shall not exceed 10% or a value of 4, whichever is greater, above or below the original limits of acceptable color range for the color specified, as color is expressed in units of color measures (DELTA E) derived by photoelectric trisulphur colorimetry as described by circular B-429 of the National Bureau of Standards.

"Excessive non-uniformity" means non-uniform fading during the period of the warranty to the extent that adjacent panels have a color difference greater than the original limits of acceptable color expressed in the same system of color measurement described above.

"Will not pit or corrode" means that there shall be no pitting or other type of corrosion discernible by the naked eye from a distance of 10 feet resulting from the natural elements in the atmosphere at the project site.

This Warranty applies only if such anodized material is installed in strict accordance with CAP's recommended practices and maintained in accordance with American Architectural Manufacturers Association (AAMA) Publication Number 609.1 "Voluntary Guide Specification for Cleaning and Maintenance of Architectural Anodized Aluminum". AAMA Publication No. 609.1 will be furnished upon request. This Warranty does not cover, and CAP hereby expressly disclaims, all liability for and with respect to any material which has been subject to abuse, alteration, modification, neglect, misuse, abnormal use, accident, fire, war, flood, earthquake or acts of God.

The sole and exclusive remedy with respect to this Warranty shall be repair or replacement of the defective material or repayment by CAP of the purchase price paid therefore. CAP reserves the right to select the remedy.

The foregoing is extended solely to the Customer and is granted IN LIEU OF ALL OTHER GUARANTEES AND WARRANTIES, EXPRESSED OR IMPLIED, INCLUDING, WITHOUT THE GENERALITY OF THE FOREGOING, ANY GUARANTEE OR WARRANTY OF MERCHANTABILITY OF FITNESS FOR A PARTICULAR PURPOSE.

Coral Architectural Products

Representative

Customer Service Manager

Title

March 2017

To Be Advised

Date

www.coralap.com

SAMPLE WARRANTIES

Painted Finish Limited Warranty

D2000 Powder Coat Finish

Customer: _____

Project: _____

Date of Substantial Completion: _____

This conditional limited warranty is in addition to the Coral Architectural Product's conditional limited standard product warranty. Coral Architectural Products (CAP) warrants that during the warranty period there will be:

Clause 1

- No visible checking* or cracking* of the **Interpon D2000™** powder coating.
- No chalking* of the **Interpon D2000™** powder coating in excess of that represented by Number 8 rating based on ASTM D4214.
- No color change of the **Interpon D2000™** powder coating greater than 5 (five) CIE Lab AE units calculated in accordance with ASTM 2244 Section 6.3. Color change shall be measured on the exposed surface which has been cleaned of oil, grease, chalk and oxidized film or other contaminants. Corresponding values shall be measured on the original retained batch panel. (Panel stored in the dark at temperatures below 30° C).

Clause 2

- Gloss Retention of the **Interpon D2000™** powder coating when applied to test panels will be greater than or equal to 30% after 5 years exposure in Florida (facing 45° South) in accordance with the requirements of AAMA 2604-02 Clause 7.9.1.4.2.
- Adhesion of the **Interpon D2000™** powder coating when initially applied to test panels and measured by reference to AAMA 2604-02 Clause 7.4.2 will show no removal of the film.

Warranty Terms and Conditions

- The "Warranty Period" for the warranties in Clause 1 shall mean the period of fifteen (15) years, and for the warranty in Clause 2 shall mean five (5) years, commencing on the date of substantial completion of the project or six months from the date of the initial shipment, whichever is sooner?
- Color measurements (delta E) are measured at 10 degrees and on exposed coated surfaces that have been cleaned of all external deposits including chalk and compared to the original unexposed coated surface. For comparison purposes, CAP will maintain a standard paint panel and/or documentation indicating color, gloss and other properties. It is understood that fading may not be uniform if the coated surfaces are not equally exposed to the sun and weathering elements. Prior to the determination of a gloss value using an angle of incidence of 60 degrees following ASTM D523, the surface must be cleaned using a 1% aqueous solution of a wetting agent with a soft sponge under light pressure.
- This warranty extends only to parts exposed to normal atmospheric conditions in the United States.
- A systematic maintenance program must be instituted to clean the surface periodically so as to prevent accumulations of salt deposits and harmful pollutants.
- This Warranty applies only if such painted material is installed in strict accordance with CAP's recommended practices and maintained in accordance with American Architectural Manufacturers Association (AAMA) Publication Number 610.1 "Voluntary Guide Specification for Cleaning and Maintenance of Architectural Painted Aluminum". AAMA Publication No. 610.1 will be furnished upon request.
- Maintenance: The cleaning recommendations for **Interpon D2000™** is an integral part of the warranty given for gloss, color retention and chalking. The warranty requires that regular cleaning has to be performed periodically, at least once a year and twice a year for structures directly exposed to areas of high salt concentration, such as near a seashore.

Painted Finish Limited Warranty

D2000 Powder Coat Finish

The conditions are as follows:

- ◆ Clean water with slight amounts of mild alkaline detergents must be used.
- ◆ The cleaning effect maybe increased by rubbing with a soft, non-scratching cloth or cotton with modest pressure.
- ◆ The temperature of the parts to be cleaned must not exceed 80° F.
- ◆ For removal of grease and oily substances isopropyl alcohol may be used.
- ◆ The cleaning solution must not be allowed to react for more than one (1) hour.
- ◆ After cleaning the surfaces must be rinsed with clean, cold water.
- ◆ A proper maintenance record has to be kept and documented. This documentation must contain the following information:
 - ✓ Date
 - ✓ Name and address of performing party
 - ✓ Description of cleaning procedure and detergents used
 - ✓ Signature of person performing the cleaning procedure

This warranty does not extend to:

- a) Damage to the coating caused by moisture or other contamination during storage of the powder or substrate or application;
- b) Damage to the coating during handling, shipping, processing, installation, improper cleaning or maintenance, etc.;
- c) Damage caused by impact, external forces, abrasion, environmental pollution, acid rain, immersion in salt water, hail, abnormal weather conditions, exposure to excessive temperatures (in excess of 150 F), solvents or chemicals, tapes, sealants, acts of God or other abuse; or
- d) Damage due to other circumstances beyond CAP's control.

Claim Procedure

In the event of a claim, claimant shall demonstrate that the failure of the product was due to a breach of this warranty and furnish proof of purchase of the defective CAP product. Claims must be made in writing within thirty days after the customer becomes aware of the failure or potential failure of the coating. CAP must be given an opportunity to inspect the substrate and coating that form the basis for the claim.

The sole and exclusive remedy with respect to this Warranty shall be repair or replacement of the defective material or repayment by CAP of the purchase price paid therefore. CAP reserves the right to select the remedy.

The foregoing is extended solely to the Customer and is granted IN LIEU OF ALL OTHER GUARANTEES AND WARRANTIES, EXPRESSED OR IMPLIED, INCLUDING, WITHOUT THE GENERALITY OF THE FOREGOING, ANY GUARANTEE OR WARRANTY OF MERCHANTABILITY OF FITNESS FOR A PARTICULAR PURPOSE.

Coral Architectural Products

Representative

Customer Service Manager
Title

To Be Advised
Date

Painted Finish Limited Warranty

D3000 Powder Coat Finish

Customer: _____

Project: _____

Date of Substantial Completion: _____

This conditional limited warranty is in addition to the Coral Architectural Product's conditional limited standard product warranty. Coral Architectural Products (CAP) warrants that during the warranty period there will be:

Clause 1

- No visible checking* or cracking* of the **Interpon D3000™** powder coating.
- No chalking* of the **Interpon D3000™** powder coating in excess of that represented by Number 8 rating based on ASTM D4214.
- No color change of the **Interpon D3000™** powder coating greater than 5 (five) CIE Lab AE units calculated in accordance with ASTM 2244 Section 6.3. Color change shall be measured on the exposed surface which has been cleaned of oil, grease, chalk, and oxidized film or other contaminants, corresponding values shall be measured on the original retained batch panel. (Panel stored in the dark at temperatures below 30° C).0° C).

Clause 2

- Gloss Retention of the **Interpon D3000™** powder coating when applied to test panels will be greater than or equal to 50% after ten (10) years exposure in Florida (facing 45° South) in accordance with the requirements of AAMA 2605-02 Clause 7.9.1.4.2.
- Adhesion of the **Interpon D3000™** powder coating when initially applied to test panels and measured by reference to AAMA 2605-02 Clause 7.4.2 will show no removal of the film.

Warranty Terms and Conditions

- The "Warranty Period" for the warranties in Clause 1 shall mean the period of twenty (20) years, and for the warranty in Clause 2 shall mean ten (10) years, commencing on the date of substantial completion of the project or six months from the date of the initial shipment, whichever is sooner?
- Color measurements (delta E) are measured at 10 degrees and on exposed coated surfaces that have been cleaned of all external deposits including chalk and compared to the original unexposed coated surface. For comparison purposes, CAP will maintain a standard paint panel and/or documentation indicating color, gloss and other properties. It is understood that fading may not be uniform if the coated surfaces are not equally exposed to the sun and weathering elements. Prior to the determination of a gloss value using an angle of incidence of 60 degrees following ASTM D523, the surface must be cleaned using a 1% aqueous solution of a wetting agent with a soft sponge under light pressure.
- This warranty extends only to parts exposed to normal atmospheric conditions in the United States.
- A systematic maintenance program must be instituted to clean the surface periodically so as to prevent accumulations of salt deposits and harmful pollutants.
- This Warranty applies only if such painted material is installed in strict accordance with CAP's recommended practices and maintained in accordance with American Architectural Manufacturers Association (AAMA) Publication Number 610.1 "Voluntary Guide Specification for Cleaning and Maintenance of Architectural Painted Aluminum". AAMA Publication No. 610.1 will be furnished upon request.
- Maintenance: The cleaning recommendations for **Interpon D3000™** is an integral part of the warranty given for gloss, color retention, and chalking. The warranty requires that regular cleaning has to be performed periodically, at least once a year and twice a year for structures directly exposed to areas of high salt concentration, such as near a seashore.

Painted Finish Limited Warranty

D3000 Powder Coat Finish

The conditions are as follows:

- ◆ Clean water with slight amounts of mild alkaline detergents must be used.
- ◆ The cleaning effect maybe increased by rubbing with a soft, non-scratching cloth or cotton with modest pressure.
- ◆ The temperature of the parts to be cleaned must not exceed 80° F.
- ◆ For removal of grease and oily substances isopropyl alcohol may be used.
- ◆ The cleaning solution must not be allowed to react for more than one (1) hour.
- ◆ After cleaning the surfaces must be rinsed with clean, cold water.
- ◆ A proper maintenance record has to be kept and documented. This documentation must contain the following information:
 - ✓ Date
 - ✓ Name and address of performing party
 - ✓ Description of cleaning procedure and detergents used
 - ✓ Signature of person performing the cleaning procedure

This warranty does not extend to:

- a) Damage to the coating caused by moisture or other contamination during storage of the powder or substrate or application;
- b) Damage to the coating during handling, shipping, processing, installation, improper cleaning or maintenance, etc.;
- c) Damage caused by impact, external forces, abrasion, environmental pollution, acid rain, immersion in salt water, hail, abnormal weather conditions, exposure to excessive temperatures (in excess of 150 F), solvents or chemicals, tapes, sealants, acts of God or other abuse; or
- d) Damage due to other circumstances beyond CAP's control.

Claim Procedure

In the event of a claim, claimant shall demonstrate that the failure of the product was due to a breach of this warranty and furnish proof of purchase of the defective CAP product. Claims must be made in writing within thirty (30) days after the customer becomes aware of the failure or potential failure of the coating. CAP must be given an opportunity to inspect the substrate and coating that form the basis for the claim.

The sole and exclusive remedy with respect to this Warranty shall be repair or replacement of the defective material or repayment by CAP of the purchase price paid therefore. CAP reserves the right to select the remedy.

The foregoing is extended solely to the Customer and is granted IN LIEU OF ALL OTHER GUARANTEES AND WARRANTIES, EXPRESSED OR IMPLIED, INCLUDING, WITHOUT THE GENERALITY OF THE FOREGOING, ANY GUARANTEE OR WARRANTY OF MERCHANTABILITY OF FITNESS FOR A PARTICULAR PURPOSE.

Coral Architectural Products

Representative

Customer Service Manager
Title

To Be Advised
Date

TERMS AND CONDITIONS OF SALE

- 1. Acceptance of Orders and Minimum Charge** – All orders are subject to credit approval and acceptance by the Seller. Minimum charge is \$50.00 net per order.
- 2. Acceptance of Terms** – Should the Buyer object to any of the Seller's terms and conditions, the Buyer must forward objections in writing to the Seller together with Buyer's purchase order or request for quotation. If a written objection is not received by the Seller, and accepted in writing by an officer of the Seller, the Buyer shall be deemed to have assented to all of the Seller's terms and conditions. None of the Buyer's terms and conditions are acceptable to the Seller unless the Buyer's terms and conditions are agreed to in writing by an officer of the Seller prior to the acceptance of the Buyer's order or as a part of the Seller's job quotation. Otherwise, the sale is conditioned upon the Buyer's acceptance of the Seller's terms and conditions and any orders accepted by the Seller are accepted and conditioned upon the Seller's terms and conditions as the only terms and conditions applicable to the sale. None of the terms and conditions in the Buyer's purchase order, acknowledgement form, confirmation or other document issued by the Buyer which conflict with the Seller's terms and conditions, or increase the Seller's obligations, shall be binding on the Seller unless specifically identified and accepted in writing by an officer of the Seller.
- 3. Claims** – Claims by the Buyer for defective materials or workmanship must be submitted in writing to the seller within ten (10) working days after receipt of shipment. Unauthorized back charges, claims, deducts, or withheld payments will not be accepted. The Seller shall have the exclusive right to select the final remedy for defective material, which will be expressly limited to the repair, replacement, or repayment of the original purchase price paid by the Buyer upon return of the material to the Seller. Seller shall not be liable for any penal, incidental or consequential damages.
- 4. Back Orders** – Back orders or any portion of the order omitted from the original shipment will be invoiced at the same price, terms, and conditions as if it were part of the original shipment.
- 5. Cancellations and Returns** – Cancellation and return of custom orders will result in substantial cost to the Buyer. The Seller will issue a credit for the scrap value only on these orders. Return or cancellation of standing stock items may be made provided the Seller has issued prior written authorization. Returns must have an Return Material Authorization number (RMA) assigned by Seller. Any standard stock material received in a resalable condition will be credited based on a 20% restocking charge of the Seller's sale price with a minimum charge of \$100.00 net. The customer must pay all freight charges on returned goods. No material will be accepted for return beyond 60 days from the original shipment date.
- 6. Change Orders** – Orders shall not be amended, modified or rescinded except by written change order signed by an authorized official of each party expressly referring to a specific change and order. All change orders affecting completed or in-process work on the Buyer's original order will be subject to a change order charge to be determined by the Seller.
- 7. Clerical Errors** – Clerical and arithmetical errors are subject to correction by the Seller.
- 8. Credit Extension** – No credit will be extended by the Seller unless the Buyer's credit has been approved and is satisfactory at the time of shipment. The Seller reserves the right, at any time, to revoke credit extended should Buyer fail to pay for goods when due or for any other reason deemed sufficient by the Seller.
- 9. Delays in Shipping** – Seller will use its best effort to ship goods ordered by Buyer on scheduled shipping dates. Seller shall not be liable to Buyer for damages for late shipments nor shall the validity of the agreement be affected by Force Majeure; meaning acts of God, fire, war, civil commotion, strikes, shortages of labor or materials, casualties, or any other conditions beyond the control of Seller. If a Buyer elects to delay shipment of goods later than the original shipping date, the Seller may invoice Buyer on original shipping date and Buyer agrees to pay as if the goods were timely shipped. Buyer also agrees to pay reasonable storage charges in the event of such delayed shipping.

- 10. Design Responsibility** – The Seller’s continuing endeavor to provide the best in product technology requires Seller to retain the right to change or modify its products without prior notice. The product illustrations used in the Seller’s brochures and catalogs are for identification only and may not represent the size or proportions by comparisons. If any material shall be manufactured or sold by the Seller to meet the Buyer’s specifications or requirements and is not part of the Seller’s standard line offered to the general trade in the usual course of the Seller’s business, then the Buyer agrees to indemnify, defend, protect and hold harmless the Seller against all claims, damages and lawsuits for actual or alleged infringement of any U.S. or foreign patent.
- 11. Entire Contract** – These terms and conditions reflect the entire agreement between the Seller and Buyer and supersedes all prior negotiations and agreements, oral or written. The agreements reflected herein may not be modified or altered except by a written agreement signed by officers of both the Seller and Buyer.
- 12. Indemnification** – Buyer waives and agrees that in the event of any breach of this agreement by Seller. Seller shall not be responsible to Buyer or any third parties for any incidental or consequential damages suffered by Buyer or third parties other than the Seller’s exclusive right to select the final remedy which will be expressly limited to the repair, replacement or repayment of the original purchase price paid by the Buyer. In the event of a claim for consequential or incidental damages, Buyer agrees to indemnify and hold harmless the Seller from such claims and damages.
- 13. Jurisdiction and Governing Law** – (Laws of State of Alabama) Any controversy or claims arising from or relating to this contract shall be settled by arbitration in accordance with the Commercial Arbitration rules of the American Arbitration Association, and judgment upon the award rendered may be entered in court having jurisdiction thereof.
- 14. Late Payment** – Unless otherwise expressly provided, all payments are Net 30 Days after date of invoice. Seller may at any time require payment in advance or satisfactory security that invoices will be paid when due, if in the Seller’s judgment the same becomes necessary. All orders are subject to credit approval and to acceptance by Seller. If payment is not made when due, 1 % per month interest will be charged thereon from the due date until paid.
- 15. Limitation of Liability** – The Seller’s only liability for defective materials shall be limited to the Seller’s exclusive right to select the final remedy which will be expressly limited to the repair, replacement or repayment of the original purchase price by the Buyer. Repayment is to be made to the Buyer upon return of defective material to the Seller. Under no circumstances will any job site repairs or replacements be made or labor charges for same be accepted.

Page Left Intentionally Blank

Section A
ENTRANCES
Table of Contents

Entrances..... A1
Adds, Substitutions and Modifications..... A2
Standard Loose Hardware..... A3

Page Left Intentionally Blank

Section A1 Table of Contents

ENTRANCES **Doors and Frames**

Entrance Door Handing Information	1
Door Types and Descriptions.....	2
Entrance Door and Numbering Information.....	3
Push/Pull Hardware Options	4
Glass Sizes	5
Standard Hardware Locations	6-7
Offset Pivot Doors and Frames.....	8-11
Offset Pivot CVR Panic Doors and Frames	12-15
Offset Pivot Offset Arm Assembly Doors and Frames	16-19
Offset Pivot CVR Panic Offset Arm Assembly Doors and Frames.....	20-23
Butt Hinge Door and Frames	24-27
Butt Hinge CVR Panic Doors and Frames.....	28-31
Butt Hinge Offset Arm Assembly Doors and Frames	32-35
Butt Hinge CVR Panic Offset Arm Assembly Doors and Frames	36-39
Center Pivot Doors and Frames.....	40-43
Showroom Doors and Frames	44-47

Page Left Intentionally Blank

Commercial aluminum storefront and entrance doors are primarily designed for:

1. Exterior applications
2. To swing or open out
3. In the case of double acting doors, to swing in and out

Because of the design, and due to building codes and life safety laws prohibiting such, single acting doors may never swing inward when installed in an exterior application. However, when used for interior applications (Example: Interior office doors), unless prevented by a particular building code, doors may swing in, or open to the interior.

HAND: All single acting swing doors are handed. The hand of a single acting swing door indicates which side it is hinged on (or will swing from) and the direction in which it is to swing. When determining the hand of a door, it should be viewed from the exterior. It will either be hinged on its left side, or hinged on its right side, and (for exterior applications) will always swing out. For interior applications, it may swing in.

The “hand” of a door is designated as follows.

For **Exterior applications** (as viewed from the exterior):

1. HL SO Hinge Left Swing Out = RH (Right Hand Door)
2. HR SO Hinge Right Swing Out = LH (Left Hand Door)

For **Interior applications** (as viewed from the exterior):

1. HL SO Hinge Left Swing Out = RH (Right Hand Door)
2. HR SI Hinge Right Swing In = RH (Right Hand Door)
3. HR SO Hinge Right Swing Out = LH (Left Hand Door)
4. HL SI Hinge Left Swing In = LH (Left Hand Door)

SINGLE ACTING commercial aluminum entrances are designed for exterior applications and to open or “swing” in an outward direction. To determine the “hand” of a single acting entrance, envision placing your back against the hinge side of the opening and extend whichever hand would be appropriate for the direction the door opens.

Only entrances used in interior applications are allowed to swing in an inward direction. The same method described above for determining the “hand” of the door applies

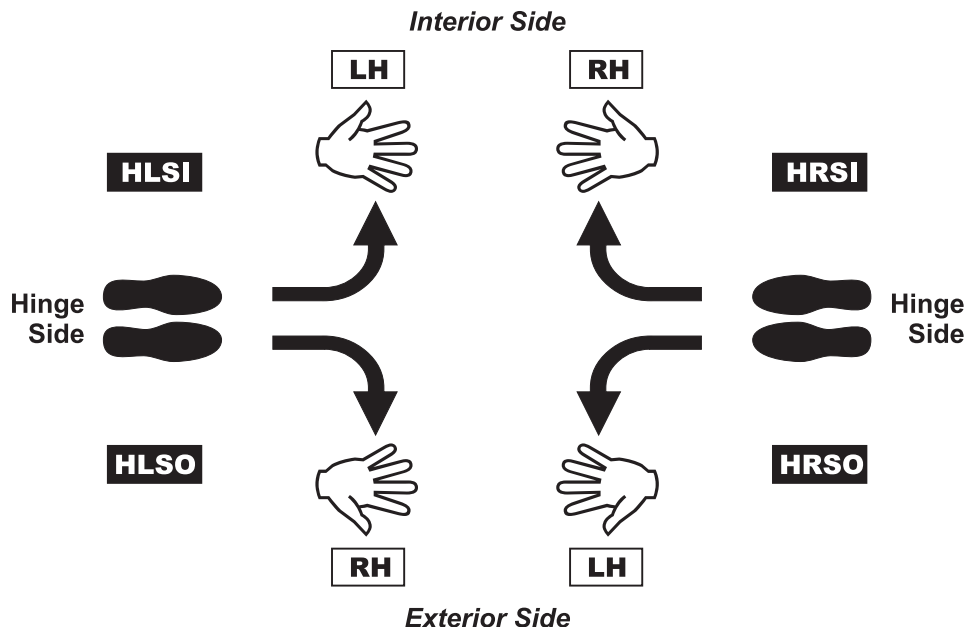

Entrances

Door Types & Descriptions

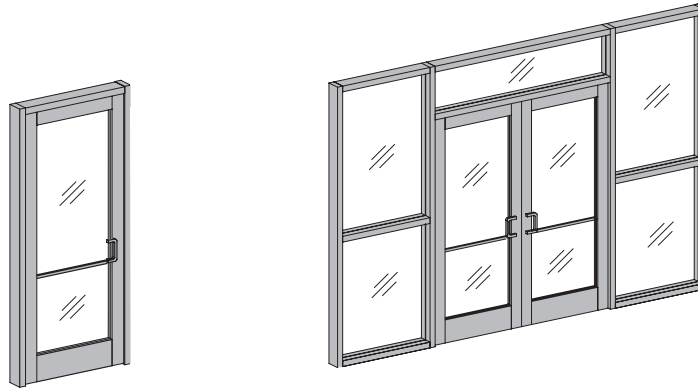

Aluminum Entrance Doors	VERTICAL STILE	TOP RAIL	BOTTOM RAIL	RECOMMENDED LIMITATIONS	TRAFFIC APPLICATION
Series 213 Narrow Stile	2 1/8"	2 1/4"	4"	3'-3" x 8'-0"	Normal
Series 380 Medium Stile	3 3/4"	4"	7 1/2"	3'-6" x 9'-0"	Moderate
Series 500 Wide Stile	5"	4"	7 1/2"	3'-6" x 9'-0"	Heavy

Note: Entrance doors exceeding 3'-6" in width or 7'-6" in height require an intermediate butt hinge or pivot.

COMMON DOOR AND FRAME DESCRIPTIONS

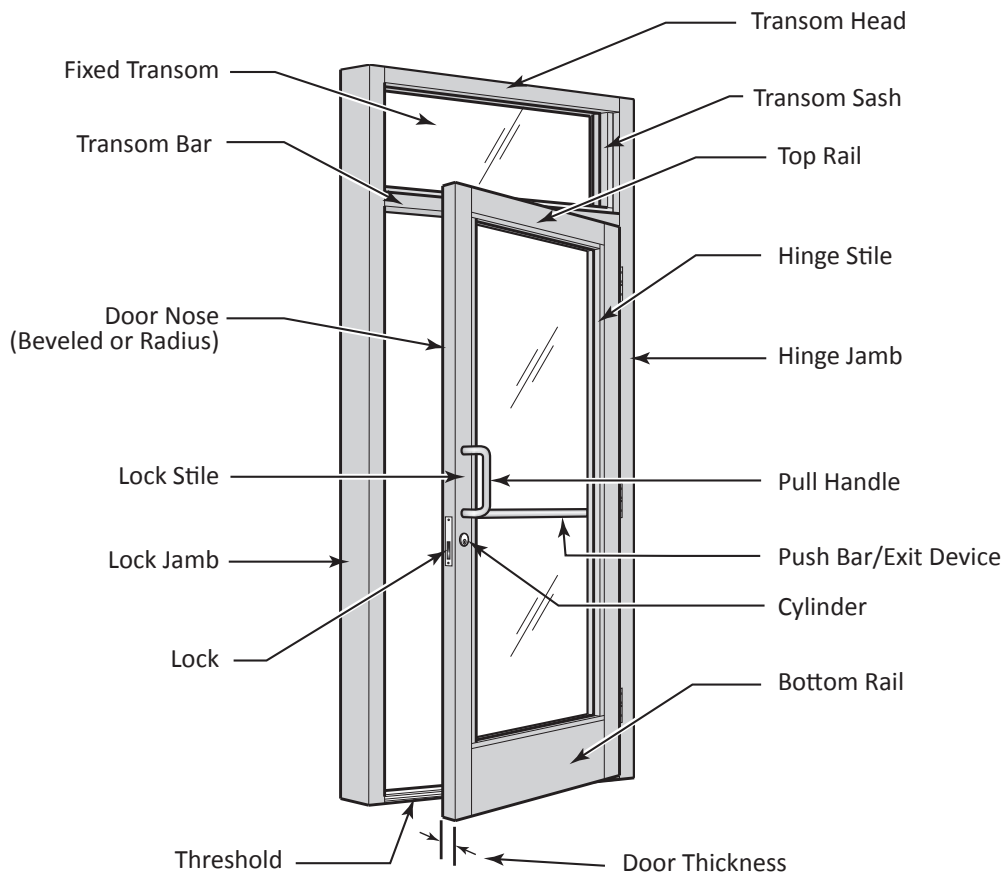

**DOOR
PART NUMBER
INFORMATION**

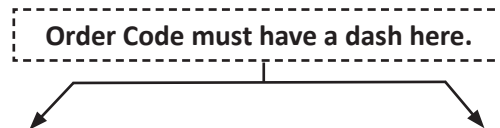

D.O.W. (Inches)	D.O.H. (Inches)	STILE WIDTH	SWING & HINGING	ADDED HARDWARE	FINISH CODE
36 <i>(Specify)</i>	84 <i>(Specify)</i>	<i>(Select)</i>	C <i>(Select)</i>	O <i>(Select)</i>	10 <i>(Select)</i>
DOOR OPENING WIDTH	DOOR OPENING HEIGHT	NARROW = LEAVE BLANK MEDIUM = MS WIDE = WS	FROM CHART 1	P = CVR PANIC O = OFFSET ARM	#10 CLEAR #20 BRONZE # 81 White PC #99 2604 PC #89 2605 PC

For example: (3684-CYO-10)

The above example depicts a 3684 Right Hand Offset Pivot Door with D108 Bottom Rail for Offset Arm in Clear Anodized Finish

NOTE: After "Swing and Hinging" Code, Add "Y" for D108 or "Z" for D109 Bottom Rail Substitutions. (D108 is standard on Series 380 and 500 doors)

**FRAME
PART NUMBER
INFORMATION**

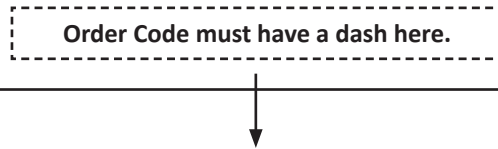

D.O.W. (INCHES)	D.O.H. (Inches)	SWING & HINGING	ADDED HARDWARE	FRAME TYPE	FINISH CODE
36 <i>(Specify)</i>	84 <i>(Specify)</i>	C <i>(Select)</i>	O <i>(Select)</i>	F2 <i>(Select)</i>	10 <i>(Select)</i>
DOOR OPENING WIDTH	DOOR OPENING HEIGHT	FROM CHART 1	P= PANIC O= OFFSET ARM	F2= FRAME FT2= FRAME W/TRANSOM F3= FRAME FT3= FRAME W/TRANSOM	#10 CLEAR #20 BRONZE # 81 White PC #99 2604 PC #89 2605 PC

For example: (3684-C-F2-10)

The above example depicts a 3684 Right Hand Offset Pivot Frame in Clear Anodized Finish

F2 = 1 3/4" x 4 1/2" Frame
FT2 = 1 3/4" x 4 1/2" Frame w/ Transom
F3 = 2" x 4 1/2" Frame
FT3 = 2" x 4 1/2" Frame w/ Transom

CHART 1

	BUTT HINGE	OFFSET PIVOT	CENTER PIVOT
RIGHT HAND SINGLE	A	C	G
LEFT HAND SINGLE	B	D	H
PAIR OF DOORS	J	K	M

Entrances

Push/Pull Hardware

Traditional Hardware Standard on all Doors

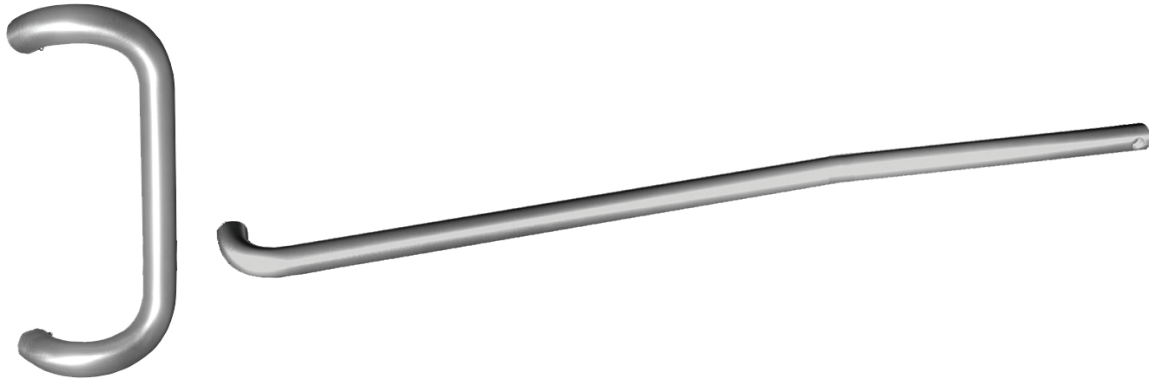

Clear Push/Pull is standard on clear and powder coated doors.
Champagne Push/Pull is standard on bronze doors.

GLASS SIZES FOR SERIES 213, SERIES 380 AND SERIES 500 STANDARD ENTRANCE DOORS

DOOR OPENING	STILE TYPE	TOP RAIL (PART NUMBER)	TOP RAIL HEIGHT	BOTTOM RAIL (PART NUMBER)	BOTTOM RAIL HEIGHT	STILE WIDTH	GLASS SIZE
3684 or 7284	NS213	D101	2 ¼"	D102	4"	2 ½"	31 ½" x 76 ½"
3684 or 7284	NS213	D102	4"	D102	4"	2 ½"	31 ½" x 74 ¼"
3684 or 7284	NS213	D101	2 ¼"	D108	7 ½"	2 ½"	31 ½" x 73"
3684 or 7284	NS213	D101	2 ¼"	D109	9 ½"	2 ½"	31 ½" x 71"
3684 or 7284	MS380	D102	4"	D108	7 ½"	3 ¾"	27 ⅞" x 71 ¼"
3684 or 7284	WS500	D102	4"	D108	7 ½"	5"	25 ⅜" x 71 ¼"
3684 or 7284	MS380	D102	4"	D109	9 ½"	3 ¾"	27 ⅞" x 69 ¼"
3684 or 7284	WS500	D102	4"	D109	9 ½"	5"	25 ⅜" x 69 ¼"
4284 or 8484	NS213	D101	2 ¼"	D102	4"	2 ½"	37 ½" x 76 ½"
4284 or 8484	NS213	D102	4"	D102	4"	2 ½"	37 ½" x 74 ¼"
4284 or 8484	NS213	D101	2 ¼"	D108	7 ½"	2 ½"	37 ½" x 73"
4284 or 8484	NS213	D101	2 ¼"	D109	9 ½"	2 ½"	37 ½" x 71"
4284 or 8484	MS380	D102	4"	D108	7 ½"	3 ¾"	33 ⅞" x 71 ¼"
4284 or 8484	WS500	D102	4"	D108	7 ½"	5"	31 ⅜" x 71 ¼"
4284 or 8484	MS380	D102	4"	D109	9 ½"	3 ¾"	33 ⅞" x 69 ¼"
4284 or 8484	WS500	D102	4"	D109	9 ½"	5"	31 ⅜" x 69 ¼"

GLASS WIDTH FORMULAS (inches)

SINGLE or PAIR	FORMULA
Single	NS213= D.O.W. minus 4 ⅞"
Pair	NS213= D.O.W. divided by 2 minus 4 ⅞"
Single	MS380= D.O.W. minus 8 ⅞"
Pair	MS380= D.O.W. divided by 2 minus 8 ⅞"
Single	WS500= D.O.W. minus 10 ⅞"
Pair	WS500= D.O.W. divided by 2 minus 10 ⅞"

Note: D.O.W. = Door Opening Width

GLASS HEIGHT FORMULAS (inches)

STEP #			EXAMPLE	
1)	D.O.H. Door Height dimension specified is:		84"	
2)	Deduct clearance at Door Frame Header:	- ⅞"	(- ⅞")	N/A
3)	Deduct Top Rail dimension:	Select	(-2 ¼")	Part # = (D101)
4)	Deduct Bottom Rail dimension:	Select	(-4")	Part # = (D102)
5)	Deduct clearance between Bottom of Door and Top of Threshold:	- ⅜"	(- ⅜")	N/A
6)	Deduct for height of Threshold:	- ½"	(- ½")	Part # = (TH4)
7)	Deduct for Glass Bite and Setting Block:	- ⅜"	(- ⅜")	N/A
Note: D.O.H. = Door Opening Height		Glass Height	(76 ½")	

Offset Pivots

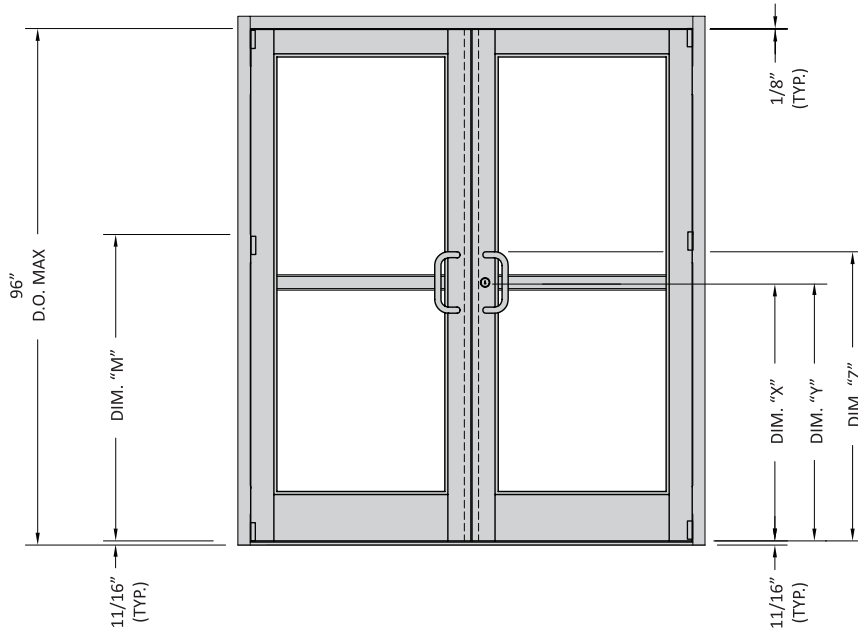

OFFSET INTERMEDIATE PIVOT LOCATION	
D.O. HEIGHT	DIM. "M"
	Offset Pivot
84"	43 ^{-27/32"}
96"	49 ^{-27/32"}

Note: D.O.H. exceeding 90" or D.O.W. exceeding 42" require an intermediate offset pivot.

HARDWARE LOCATIONS FOR PANIC DOORS				
MANUFACTURER	PANIC DEVICE	DIM "X" OF CYLINDER	DIM "Y" OF PANIC	DIM "Z" TOP OF PULL
FIRST CHOICE	3192 Mid Panel	39 ⁵ / ₃₂ "	41 ³ / ₃₂ "	44 ⁵ / ₃₂ "
FIRST CHOICE	3692 C.V.R.	41 ⁹ / ₁₆ "	40 ⁵ / ₈ "	46 ⁹ / ₁₆ "
FIRST CHOICE	3792 RIM	41 ⁹ / ₁₆ "	41 ⁵ / ₁₆ "	46 ⁹ / ₁₆ "

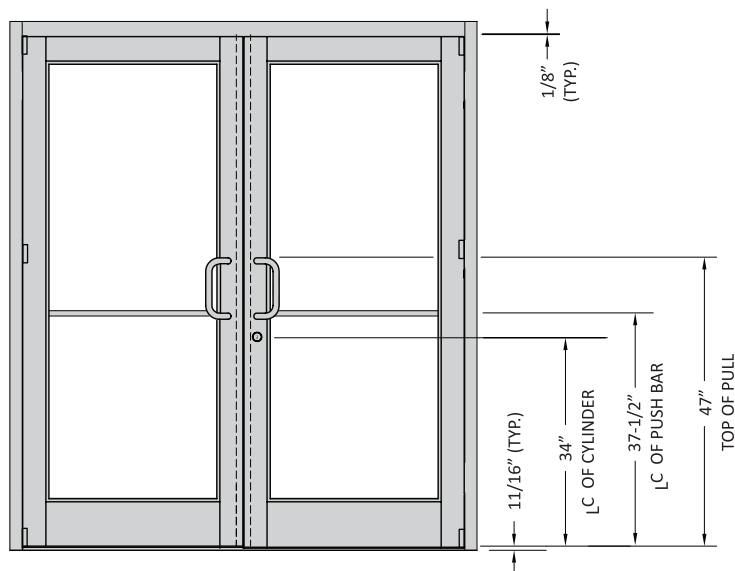

Note: Medium Stile Doors used for Illustration Purposes. Hardware locations are similar for Narrow and Wide Stile Doors

Butt Hinge

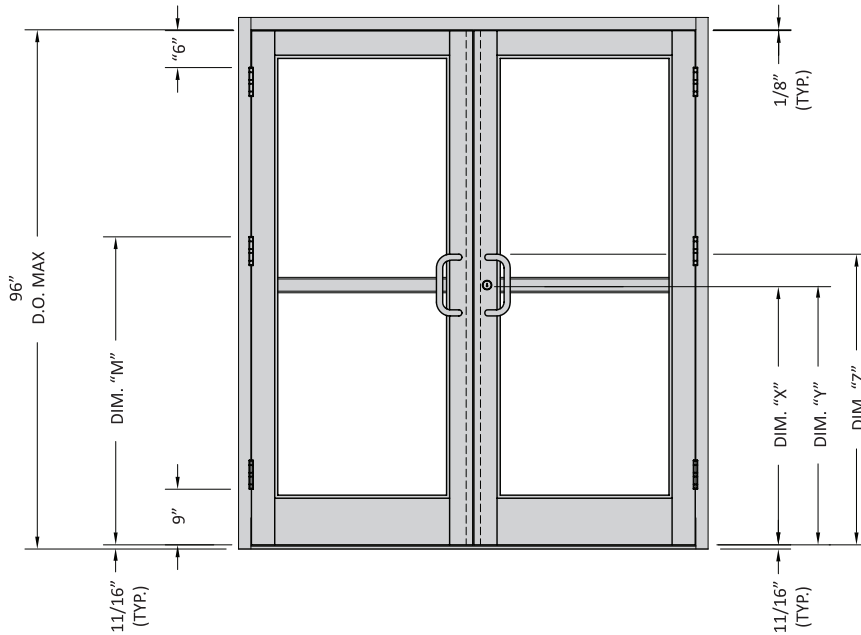

INTERMEDIATE HINGE	
D.O. HEIGHT	DIM. "M"
	BUTT HINGE
84"	45 ¹¹ / ₃₂ "
96"	51 ¹¹ / ₃₂ "

Note: D.O.H. exceeding 90" or D.O.W. exceeding 42" require an intermediate hinge.

HARDWARE LOCATIONS FOR PANIC DOORS				
MANUFACTURER	PANIC DEVICE	CL OF CYLINDER	CL OF PANIC	DIM "Z" TOP OF PULL
FIRST CHOICE	3192 Mid Panel	39 ⁵ / ₃₂ "	41 ³ / ₃₂ "	44 ⁵ / ₃₂ "
FIRST CHOICE	3692 C.V.R.	41 ⁹ / ₁₆ "	40 ⁵ / ₈ "	46 ⁹ / ₁₆ "
FIRST CHOICE	3792 RIM	41 ⁹ / ₁₆ "	41 ⁵ / ₁₆ "	46 ⁹ / ₁₆ "

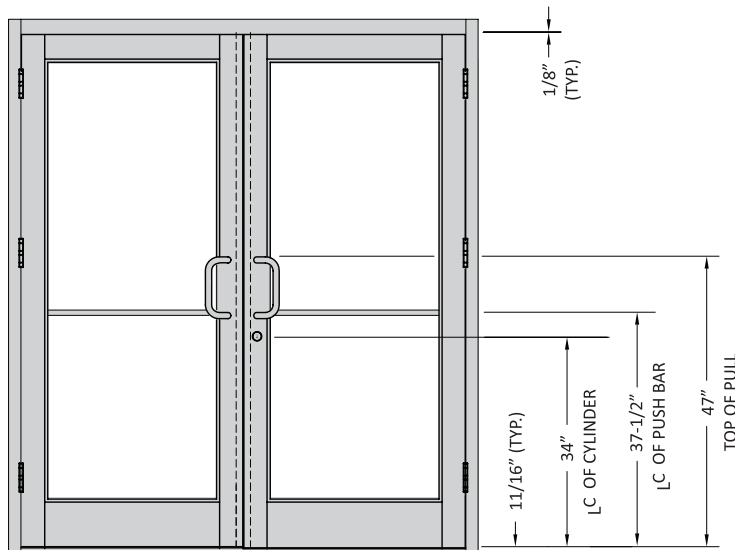

Note: Medium Stile Doors used for Illustration Purposes. Hardware locations are similar for Narrow and Wide Stile Doors

Entrances

Standard Doors • Offset Pivot

Offset Pivot Door Package Includes

- Traditional 1" rd Pull/Push Hardware
- Glass Stops for ¼" Glazing
- Top & Bottom Door Pivots
- MS Hook Bolt - Single or Active Leaf
- Top & Bottom Flush Bolts Inactive Leaf
- Keyed Cylinder Exterior
- Thumb Turn Interior

Note: Reference Hardware Section of the Price Catalog for Door Closers and Loose Hardware Items not included in Standard Entrance section.

Note: All Hardware on Powder coat products is furnished in a standard clear finish.

Order Number Example: 3684MS-D (Size and Series) - (Hand or Pair)

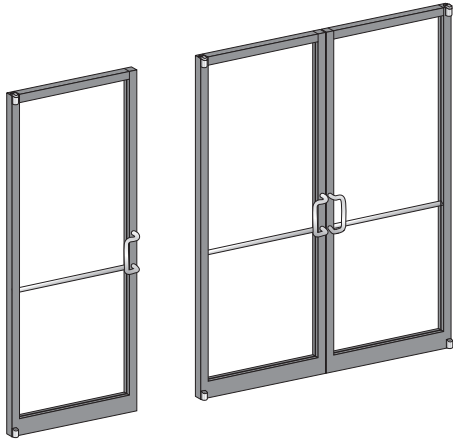

SERIES 213 NARROW STILE						
HAND	DESCRIPTION	FINISH CODE / DOOR PRICE				
		#10 CLEAR	#20 BRONZE	#81 WHITE	#2604 POWDER	#2605 POWDER
RH	3684-C	\$398	\$425	\$425	\$580	\$616
LH	3684-D	\$398	\$425	\$425	\$580	\$616
RH	4284-C	\$495	\$517	\$517	\$617	\$655
LH	4284-D	\$495	\$517	\$517	\$617	\$655
PAIR	7284-K	\$792	\$845	\$845	\$1,169	\$1,236



SERIES 380 MEDIUM STILE						
HAND	DESCRIPTION	FINISH CODE / DOOR PRICE				
		#10 CLEAR	#20 BRONZE	#81 WHITE	#2604 POWDER	#2605 POWDER
RH	3684MS-C	\$517	\$544	\$544	\$652	\$694
LH	3684MS-D	\$517	\$544	\$544	\$652	\$694
RH	4284MS-C	\$551	\$574	\$574	\$694	\$738
LH	4284MS-D	\$551	\$574	\$574	\$694	\$738
PAIR	7284MS-K	\$1,087	\$1,144	\$1,144	\$1,347	\$1,429



SERIES 500 WIDE STILE						
HAND	DESCRIPTION	FINISH CODE / DOOR PRICE				
		#10 CLEAR	#20 BRONZE	#81 WHITE	#2604 POWDER	#2605 POWDER
RH	3684WS-C	\$566	\$594	\$594	\$712	\$758
LH	3684WS-D	\$566	\$594	\$594	\$712	\$758
RH	4284WS-C	\$600	\$623	\$623	\$755	\$803
LH	4284WS-D	\$600	\$623	\$623	\$755	\$803
PAIR	7284WS-K	\$1,162	\$1,220	\$1,220	\$1,446	\$1,535

Note: Add "DM001" to substitute DG101 Glass Stops used for 1" Insulated Glass.

Offset Pivot Frame Package Includes

- 1¼" or 2" x 4½" Open Back Frame
- Snap-in DS200 Door Stop w/pile
- ½" x 4" Threshold – Mill Finish
- Threshold Clips
- Top & Bottom Frame pivots
- Prep for Lock Strike
- Prep for Top & Bottom Pivots
- Prep for Top & Bottom Flush Bolts (pair)
- Frame assembly fastener package

Note: All Hardware on Powder coat products is furnished in a standard clear finish.

Note: Standard Frame Height for Transom Frames = 10'-5 ½".

Order Number Example: 3684-D-FT2 (Size) - (Hand or Pair) - (Type)

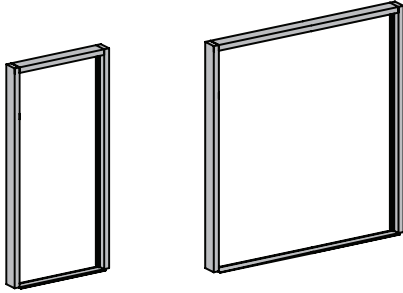

FL200 DOOR FRAME (Non-Transom)						
HAND	DESCRIPTION	FINISH CODE / FRAME PRICE				
		#10 CLEAR	#20 BRONZE	#81 WHITE	#2604 POWDER	#2605 POWDER
RH	3684-C-F2	\$250	\$260	\$260	\$369	\$398
LH	3684-D-F2	\$250	\$260	\$260	\$369	\$398
RH	4284-C-F2	\$280	\$291	\$291	\$379	\$408
LH	4284-D-F2	\$280	\$291	\$291	\$379	\$408
PAIR	7284-K-F2	\$305	\$316	\$316	\$447	\$482

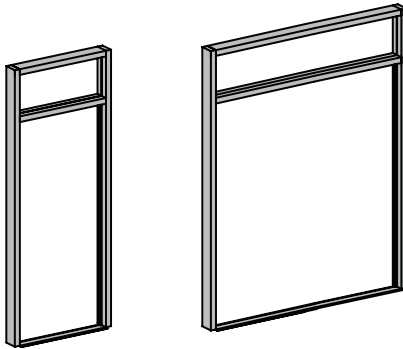

FL200 DOOR FRAME WITH TRANSOM						
HAND	DESCRIPTION	FINISH CODE / FRAME PRICE				
		#10 CLEAR	#20 BRONZE	#81 WHITE	#2604 POWDER	#2605 POWDER
RH	3684-C-FT2	\$330	\$345	\$345	\$522	\$561
LH	3684-D-FT2	\$330	\$345	\$345	\$522	\$561
RH	4284-C-FT2	\$406	\$422	\$422	\$537	\$577
LH	4284-D-FT2	\$406	\$422	\$422	\$537	\$577
PAIR	7284-K-FT2	\$413	\$431	\$431	\$635	\$683

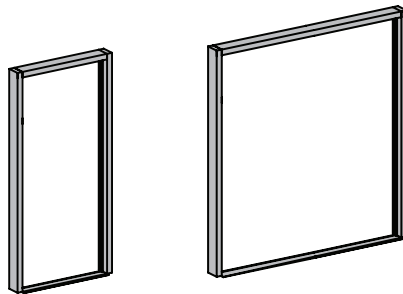

FL300 DOOR FRAME (Non-Transom)						
HAND	DESCRIPTION	FINISH CODE / FRAME PRICE				
		#10 CLEAR	#20 BRONZE	#81 WHITE	#2604 POWDER	#2605 POWDER
RH	3684-C-F3	\$257	\$267	\$267	\$378	\$407
LH	3684-D-F3	\$257	\$267	\$267	\$378	\$407
RH	4284-C-F3	\$287	\$299	\$299	\$388	\$418
LH	4284-D-F3	\$287	\$299	\$299	\$388	\$418
PAIR	7284-K-F3	\$313	\$325	\$325	\$460	\$494

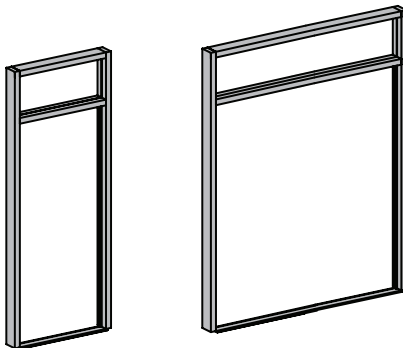

FL300 DOOR FRAME WITH TRANSOM						
HAND	DESCRIPTION	FINISH CODE / FRAME PRICE				
		#10 CLEAR	#20 BRONZE	#81 WHITE	#2604 POWDER	#2605 POWDER
RH	3684-C-FT3	\$366	\$384	\$384	\$599	\$647
LH	3684-D-FT3	\$366	\$384	\$384	\$599	\$647
RH	4284-C-FT3	\$453	\$473	\$473	\$614	\$662
LH	4284-D-FT3	\$453	\$473	\$473	\$614	\$662
PAIR	7284-K-FT3	\$453	\$475	\$475	\$717	\$775

Entrances

Standard Doors • Offset Pivot

Offset Pivot Door Package Includes

- Traditional 1" rd Pull/Push Hardware
- Glass Stops for ¼" Glazing
- Top, Bottom & Intermediate Door Pivots
- MS Hook Bolt - Single or Active Leaf
- Top & Bottom Flush Bolts Inactive Leaf
- Keyed Cylinder Exterior
- Thumb Turn Interior

*Note: Reference Hardware Section of the Price Catalog for Door Closers and Loose Hardware Items not included in Standard Entrance section.
Note: All Hardware on Powder coat products is furnished in a standard clear finish.*

Order Number Example: **3696MS-D** (Size and Series) - (Hand or Pair)



SERIES 213 NARROW STILE						
HAND	DESCRIPTION	FINISH CODE / DOOR PRICE				
		#10 CLEAR	#20 BRONZE	#81 WHITE	#2604 POWDER	#2605 POWDER
RH	3696-C	\$534	\$563	\$563	\$663	\$703
LH	3696-D	\$534	\$563	\$563	\$663	\$703
RH	4296-C	\$568	\$591	\$591	\$703	\$745
LH	4296-D	\$568	\$591	\$591	\$703	\$745
PAIR	7296-K	\$1,102	\$1,160	\$1,160	\$1,334	\$1,408



SERIES 380 MEDIUM STILE						
HAND	DESCRIPTION	FINISH CODE / DOOR PRICE				
		#10 CLEAR	#20 BRONZE	#81 WHITE	#2604 POWDER	#2605 POWDER
RH	3696MS-C	\$592	\$621	\$621	\$741	\$788
LH	3696MS-D	\$592	\$621	\$621	\$741	\$788
RH	4296MS-C	\$629	\$653	\$653	\$787	\$835
LH	4296MS-D	\$629	\$653	\$653	\$787	\$835
PAIR	7296MS-K	\$1,235	\$1,300	\$1,300	\$1,528	\$1,619



SERIES 500 WIDE STILE						
HAND	DESCRIPTION	FINISH CODE / DOOR PRICE				
		#10 CLEAR	#20 BRONZE	#81 WHITE	#2604 POWDER	#2605 POWDER
RH	3696WS-C	\$645	\$675	\$675	\$808	\$859
LH	3696WS-D	\$645	\$675	\$675	\$808	\$859
RH	4296WS-C	\$682	\$707	\$707	\$854	\$907
LH	4296WS-D	\$682	\$707	\$707	\$854	\$907
PAIR	7296WS-K	\$1,323	\$1,385	\$1,385	\$1,639	\$1,738

Note: Add "DM001" to substitute DG101 Glass Stops used for 1" Insulated Glass.

Offset Pivot Frame Package Includes

- 1½" or 2" x 4½" Open Back Frame
- Snap-in DS200 Door Stop w/pile
- ½" x 4" Threshold – Mill Finish
- Threshold Clips
- Top & Bottom Frame Pivots
- Prep for Lock Strike
- Prep for Top, Bottom & Intermediate Pivots
- Prep for Top & Bottom Flush Bolts (pair)
- Frame assembly fastener package

Note: All Hardware on Powder coat products is furnished in a standard clear finish.

Note: Standard Frame Height for Transom Frames = 10'-5 ½".

Order Number Example: 3696-D-FT2 (Size) - (Hand or Pair) - (Type)

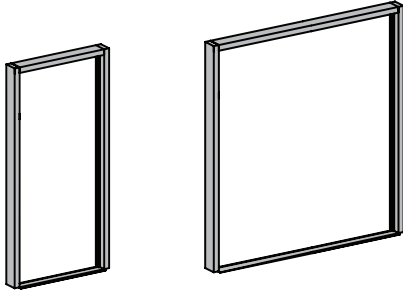

FL200 DOOR FRAME (Non-Transom)						
HAND	DESCRIPTION	FINISH CODE / FRAME PRICE				
		#10 CLEAR	#20 BRONZE	#81 WHITE	#2604 POWDER	#2605 POWDER
RH	3696-C-F2	\$308	\$320	\$320	\$414	\$446
LH	3696-D-F2	\$308	\$320	\$320	\$414	\$446
RH	4296-C-F2	\$314	\$326	\$326	\$424	\$457
LH	4296-D-F2	\$314	\$326	\$326	\$424	\$457
PAIR	7296-K-F2	\$369	\$382	\$382	\$497	\$534

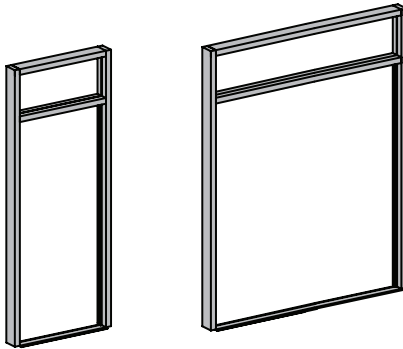

FL200 DOOR FRAME WITH TRANSMOM						
HAND	DESCRIPTION	FINISH CODE / FRAME PRICE				
		#10 CLEAR	#20 BRONZE	#81 WHITE	#2604 POWDER	#2605 POWDER
RH	3696-C-FT2	\$415	\$431	\$431	\$545	\$585
LH	3696-D-FT2	\$415	\$431	\$431	\$545	\$585
RH	4296-C-FT2	\$425	\$442	\$442	\$560	\$602
LH	4296-D-FT2	\$425	\$442	\$442	\$560	\$602
PAIR	7296-K-FT2	\$502	\$522	\$522	\$662	\$711

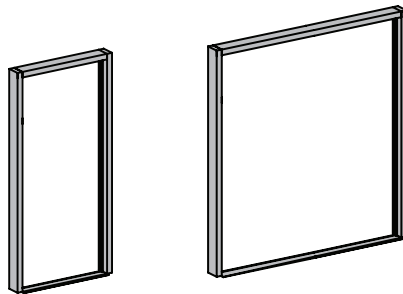

FL300 DOOR FRAME (Non-Transom)						
HAND	DESCRIPTION	FINISH CODE / FRAME PRICE				
		#10 CLEAR	#20 BRONZE	#81 WHITE	#2604 POWDER	#2605 POWDER
RH	3696-C-F3	\$316	\$328	\$328	\$424	\$457
LH	3696-D-F3	\$316	\$328	\$328	\$424	\$457
RH	4296-C-F3	\$322	\$335	\$335	\$434	\$468
LH	4296-D-F3	\$322	\$335	\$335	\$434	\$468
PAIR	7296-K-F3	\$378	\$395	\$395	\$510	\$548

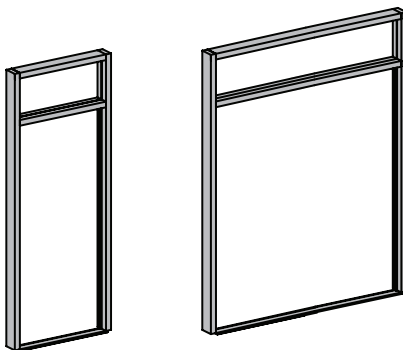

FL300 DOOR FRAME WITH TRANSMOM						
HAND	DESCRIPTION	FINISH CODE / FRAME PRICE				
		#10 CLEAR	#20 BRONZE	#81 WHITE	#2604 POWDER	#2605 POWDER
RH	3696-C-FT3	\$453	\$472	\$472	\$604	\$650
LH	3696-D-FT3	\$453	\$472	\$472	\$604	\$650
RH	4296-C-FT3	\$463	\$482	\$482	\$618	\$665
LH	4296-D-FT3	\$463	\$482	\$482	\$618	\$665
PAIR	7296-K-FT3	\$538	\$560	\$560	\$725	\$782

Entrances

Standard Doors • Offset Pivot/Panic

Offset Pivot CVR Panic Door Package Includes

- Traditional 1" rd Panic Pull
- Glass Stops for ¼" Glazing
- Top & Bottom Door Pivots
- DH3692 CVR Touch Bar Panic(s)
- Keyed Cylinder Exterior - Single or Active Leaf

*Note: Reference Hardware Section of the Price Catalog for Door Closers and Loose Hardware Items not included in Standard Entrance section.
Note: All Hardware on Powder coat products is furnished in a standard clear finish.*

Order Number Example: 3684MS-DP (Size and Series) - (Hand or Pair)



SERIES 213 NARROW STILE						
HAND	DESCRIPTION	FINISH CODE / DOOR PRICE				
		#10 CLEAR	#20 BRONZE	#81 WHITE	#2604 POWDER	#2605 POWDER
RH	3684-CP	\$644	\$663	\$663	\$859	\$895
LH	3684-DP	\$644	\$663	\$663	\$859	\$895
RH	4284-CP	\$763	\$783	\$783	\$885	\$923
LH	4284-DP	\$763	\$783	\$783	\$885	\$923
PAIR	7284-KP	\$1,315	\$1,354	\$1,354	\$1,730	\$1,798



SERIES 380 MEDIUM STILE						
HAND	DESCRIPTION	FINISH CODE / DOOR PRICE				
		#10 CLEAR	#20 BRONZE	#81 WHITE	#2604 POWDER	#2605 POWDER
RH	3684MS-CP	\$796	\$816	\$816	\$931	\$973
LH	3684MS-DP	\$796	\$816	\$816	\$931	\$973
RH	4284MS-CP	\$819	\$840	\$840	\$962	\$1,006
LH	4284MS-DP	\$819	\$840	\$840	\$962	\$1,006
PAIR	7284MS-KP	\$1,647	\$1,689	\$1,689	\$1,907	\$1,989



SERIES 500 WIDE STILE						
HAND	DESCRIPTION	FINISH CODE / DOOR PRICE				
		#10 CLEAR	#20 BRONZE	#81 WHITE	#2604 POWDER	#2605 POWDER
RH	3684WS-CP	\$845	\$866	\$866	\$992	\$1,037
LH	3684WS-DP	\$845	\$866	\$866	\$992	\$1,037
RH	4284WS-CP	\$868	\$890	\$890	\$1,023	\$1,071
LH	4284WS-DP	\$868	\$890	\$890	\$1,023	\$1,071
PAIR	7284WS-KP	\$1,722	\$1,766	\$1,766	\$2,005	\$2,095

Note: Add "DM001" to substitute DG101 Glass Stops used for 1" Insulated Glass.

Offset Pivot CVR Panic Frame Package Includes

- 1 1/4" or 2" x 4 1/2" Open Back Frame
- Snap-in DS200 Door Stop w/pile
- 1/2" x 4" Threshold – Mill Finish
- Threshold Clips
- Top & Bottom Frame Pivots
- Prep for DH3692 CVR Panic(s)
- Prep for Top & Bottom Pivots
- Frame assembly fastener package

Note: All Hardware on Powder coat products is furnished in a standard clear finish.

Note: Standard Frame Height for Transom Frames = 10'-5 1/2".

Order Number Example: **3684-DP-F2** (Size) - (Hand or Pair) - (Type)

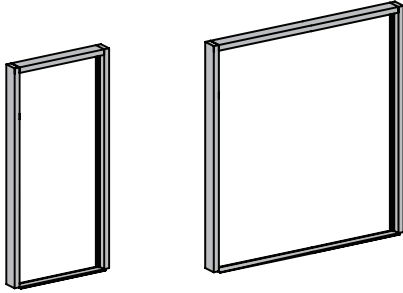

FL200 DOOR FRAME (Non-Transom)						
HAND	DESCRIPTION	FINISH CODE / FRAME PRICE				
		#10 CLEAR	#20 BRONZE	#81 WHITE	#2604 POWDER	#2605 POWDER
RH	3684-CP-F2	\$268	\$278	\$278	\$383	\$411
LH	3684-DP-F2	\$268	\$278	\$278	\$383	\$411
RH	4284-CP-F2	\$293	\$304	\$304	\$393	\$422
LH	4284-DP-F2	\$293	\$304	\$304	\$393	\$422
PAIR	7284-KP-F2	\$322	\$334	\$334	\$460	\$494

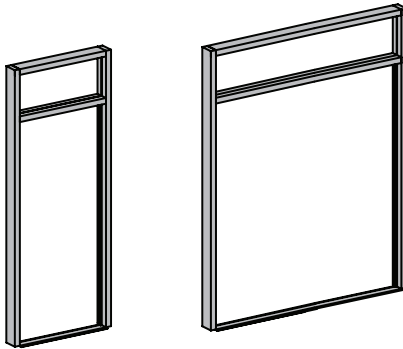

FL200 DOOR FRAME WITH TRANSOM						
HAND	DESCRIPTION	FINISH CODE / FRAME PRICE				
		#10 CLEAR	#20 BRONZE	#81 WHITE	#2604 POWDER	#2605 POWDER
RH	3684-CP-FT2	\$370	\$384	\$384	\$536	\$574
LH	3684-DP-FT2	\$370	\$384	\$384	\$536	\$574
RH	4284-CP-FT2	\$420	\$436	\$436	\$551	\$591
LH	4284-DP-FT2	\$420	\$436	\$436	\$551	\$591
PAIR	7284-KP-FT2	\$452	\$470	\$470	\$648	\$695

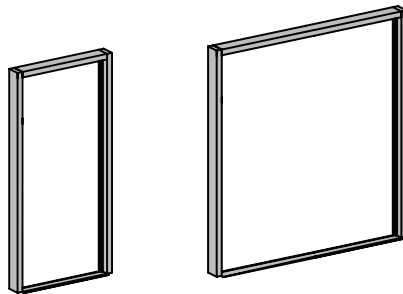

FL300 DOOR FRAME (Non-Transom)						
HAND	DESCRIPTION	FINISH CODE / FRAME PRICE				
		#10 CLEAR	#20 BRONZE	#81 WHITE	#2604 POWDER	#2605 POWDER
RH	3684-CP-F3	\$275	\$285	\$285	\$392	\$421
LH	3684-DP-F3	\$275	\$285	\$285	\$392	\$421
RH	4284-CP-F3	\$301	\$312	\$312	\$402	\$432
LH	4284-DP-F3	\$301	\$312	\$312	\$402	\$432
PAIR	7284-KP-F3	\$320	\$332	\$332	\$472	\$507

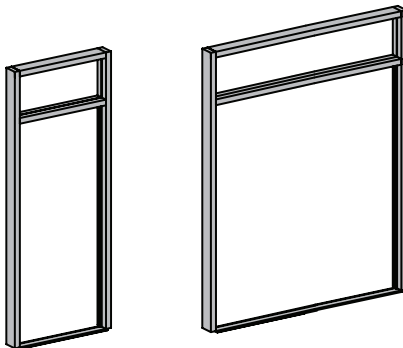

FL300 DOOR FRAME WITH TRANSOM						
HAND	DESCRIPTION	FINISH CODE / FRAME PRICE				
		#10 CLEAR	#20 BRONZE	#81 WHITE	#2604 POWDER	#2605 POWDER
RH	3684-CP-FT3	\$406	\$425	\$425	\$613	\$660
LH	3684-DP-FT3	\$406	\$425	\$425	\$613	\$660
RH	4284-CP-FT3	\$466	\$486	\$486	\$627	\$676
LH	4284-DP-FT3	\$466	\$486	\$486	\$627	\$676
PAIR	7284-KP-FT3	\$460	\$484	\$484	\$730	\$787

Entrances

Standard Doors • Offset Pivot/Panic

Offset Pivot CVR Panic Door Package Includes

- Traditional 1" rd Panic Pull
- Glass Stops for ¼" Glazing
- Top, Bottom, & Intermediate Door Pivots
- DH3692 CVR Touch Bar Panic(s)
- Keyed Cylinder Exterior - Single or Active Leaf

Note: Reference Hardware Section of the Price Catalog for Door Closers and Loose Hardware Items not included in Standard Entrance section.

Note: All Hardware on Powder coat products is furnished in a standard clear finish.

Order Number Example: **3696MS-DP** (Size and Series) - (Hand or Pair)



SERIES 213 NARROW STILE						
HAND	DESCRIPTION	FINISH CODE / DOOR PRICE				
		#10 CLEAR	#20 BRONZE	#81 WHITE	#2604 POWDER	#2605 POWDER
RH	3696-CP	\$814	\$835	\$835	\$942	\$983
LH	3696-DP	\$814	\$835	\$835	\$942	\$983
RH	4296-CP	\$836	\$858	\$858	\$971	\$1,013
LH	4296-DP	\$836	\$858	\$858	\$971	\$1,013
PAIR	7296-KP	\$1,664	\$1,708	\$1,708	\$1,896	\$1,970



SERIES 380 MEDIUM STILE						
HAND	DESCRIPTION	FINISH CODE / DOOR PRICE				
		#10 CLEAR	#20 BRONZE	#81 WHITE	#2604 POWDER	#2605 POWDER
RH	3696MS-CP	\$871	\$893	\$893	\$1,020	\$1,067
LH	3696MS-DP	\$871	\$893	\$893	\$1,020	\$1,067
RH	4296MS-CP	\$897	\$920	\$920	\$1,054	\$1,103
LH	4296MS-DP	\$897	\$920	\$920	\$1,054	\$1,103
PAIR	7296MS-KP	\$1,800	\$1,846	\$1,846	\$2,088	\$2,179



SERIES 500 WIDE STILE						
HAND	DESCRIPTION	FINISH CODE / DOOR PRICE				
		#10 CLEAR	#20 BRONZE	#81 WHITE	#2604 POWDER	#2605 POWDER
RH	3696WS-CP	\$924	\$947	\$947	\$1,087	\$1,138
LH	3696WS-DP	\$924	\$947	\$947	\$1,087	\$1,138
RH	4296WS-CP	\$950	\$974	\$974	\$1,122	\$1,175
LH	4296WS-DP	\$950	\$974	\$974	\$1,122	\$1,175
PAIR	7296WS-KP	\$1,883	\$1,930	\$1,930	\$2,199	\$2,298

Note: Add "DM001" to substitute DG101 Glass Stops used for 1" Insulated Glass.

Offset Pivot CVR Panic Frame Package Includes

- 1 1/4" or 2" x 4 1/2" Open Back Frame
- Snap-in DS200 Door Stop w/pile
- 1/2" x 4" Threshold – Mill Finish
- Threshold Clips
- Top & Bottom Frame Pivots
- Prep for DH3692 CVR Panic(s)
- Prep for Intermediate Pivots
- Frame assembly fastener package

Note: All Hardware on Powder coat products is furnished in a standard clear finish.

Note: Standard Frame Height for Transom Frames = 10'-5 1/2".

Order Number Example: **3684-DP-FT2** (Size) - (Hand or Pair) - (Type)

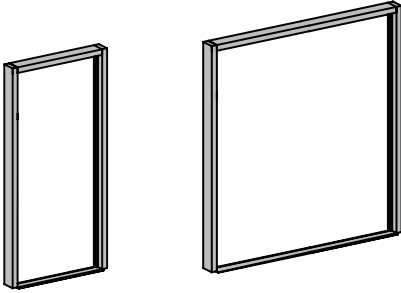

FL200 DOOR FRAME (Non-Transom)						
HAND	DESCRIPTION	FINISH CODE / FRAME PRICE				
		#10 CLEAR	#20 BRONZE	#81 WHITE	#2604 POWDER	#2605 POWDER
RH	3696-CP-F2	\$321.00	\$333.00	\$333.00	\$428.00	\$459.00
LH	3696-DP-F2	\$321.00	\$333.00	\$333.00	\$428.00	\$459.00
RH	4296-CP-F2	\$328.00	\$340.00	\$340.00	\$438.00	\$470.00
LH	4296-DP-F2	\$328.00	\$340.00	\$340.00	\$438.00	\$470.00
PAIR	7296-KP-F2	\$382.00	\$395.00	\$395.00	\$509.00	\$547.00

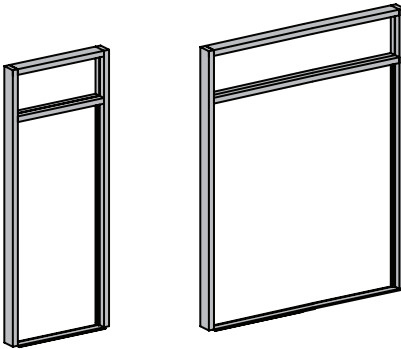

FL200 DOOR FRAME WITH TRANSOM						
HAND	DESCRIPTION	FINISH CODE / FRAME PRICE				
		#10 CLEAR	#20 BRONZE	#81 WHITE	#2604 POWDER	#2605 POWDER
RH	3696-CP-FT2	\$428	\$444	\$444	\$559	\$598
LH	3696-DP-FT2	\$428	\$444	\$444	\$559	\$598
RH	4296-CP-FT2	\$439	\$455	\$455	\$574	\$615
LH	4296-DP-FT2	\$439	\$455	\$455	\$574	\$615
PAIR	7296-KP-FT2	\$515	\$535	\$535	\$675	\$724

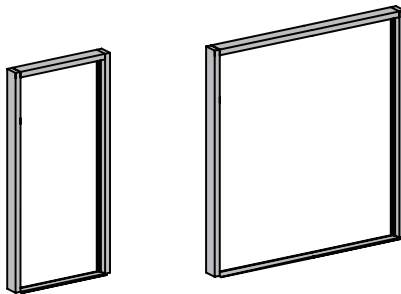

FL300 DOOR FRAME (Non-Transom)						
HAND	DESCRIPTION	FINISH CODE / FRAME PRICE				
		#10 CLEAR	#20 BRONZE	#81 WHITE	#2604 POWDER	#2605 POWDER
RH	3696-CP-F3	\$329	\$341	\$341	\$438	\$470
LH	3696-DP-F3	\$329	\$341	\$341	\$438	\$470
RH	4296-CP-F3	\$336	\$348	\$348	\$448	\$482
LH	4296-DP-F3	\$336	\$348	\$348	\$448	\$482
PAIR	7296-KP-F3	\$393	\$408	\$408	\$523	\$561

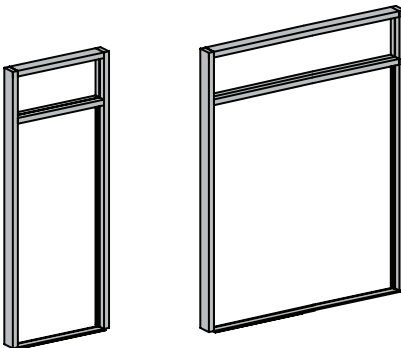

FL300 DOOR FRAME WITH TRANSOM						
HAND	DESCRIPTION	FINISH CODE / FRAME PRICE				
		#10 CLEAR	#20 BRONZE	#81 WHITE	#2604 POWDER	#2605 POWDER
RH	3696-CP-FT3	\$466	\$485	\$485	\$618	\$663
LH	3696-DP-FT3	\$466	\$485	\$485	\$618	\$663
RH	4296-CP-FT3	\$476	\$495	\$495	\$632	\$679
LH	4296-DP-FT3	\$476	\$495	\$495	\$632	\$679
PAIR	7296-KP-FT3	\$550	\$573	\$573	\$738	\$794

Entrances

Standard Doors • Offset Pivot/Offset Arm

Offset Pivot - Offset Arm Door Package Includes

- Traditional 1" rd Pull/Push Hardware
- Glass Stops for ¼" Glazing
- Top & Bottom Door Pivots
- Slide Channel installed with Offset Arm
- MS Hook Bolt - Single or Active Leaf
- Top & Bottom Flush Bolts Inactive Leaf
- Keyed Cylinder Exterior
- Thumb Turn Interior

Note: Reference Hardware Section of the Price Catalog for Door Closers and Loose Hardware Items not included in Standard Entrance section.

Note: All Hardware on Powder coat products is furnished in a standard clear finish.

Note: D102 Top Rail on Narrow Stile Doors with offset arm. DH100 Intermediate pivot used as top pivot.

Order Number Example: 3684MS-DO(Size and Series) - (Hand or Pair)

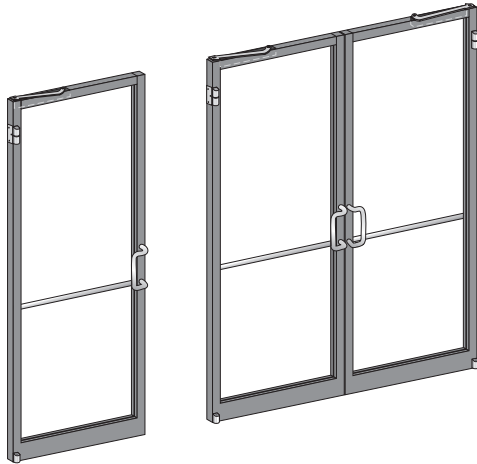

SERIES 213 NARROW STILE						
HAND	DESCRIPTION	FINISH CODE / DOOR PRICE				
		#10 CLEAR	#20 BRONZE	#81 WHITE	#2604 POWDER	#2605 POWDER
RH	3684-CO	\$605	\$633	\$633	\$725	\$762
LH	3684-DO	\$605	\$633	\$633	\$725	\$762
RH	4284-CO	\$637	\$660	\$660	\$763	\$802
LH	4284-DO	\$637	\$660	\$660	\$763	\$802
PAIR	7284-KO	\$1,241	\$1,297	\$1,297	\$1,456	\$1,526



SERIES 380 MEDIUM STILE						
HAND	DESCRIPTION	FINISH CODE / DOOR PRICE				
		#10 CLEAR	#20 BRONZE	#81 WHITE	#2604 POWDER	#2605 POWDER
RH	3684MS-CO	\$650	\$678	\$678	\$785	\$827
LH	3684MS-DO	\$650	\$678	\$678	\$785	\$827
RH	4284MS-CO	\$685	\$707	\$707	\$827	\$872
LH	4284MS-DO	\$685	\$707	\$707	\$827	\$872
PAIR	7284MS-KO	\$1,354	\$1,411	\$1,411	\$1,614	\$1,696

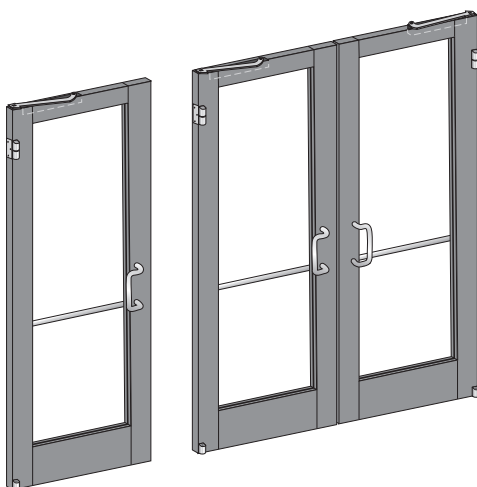

SERIES 500 WIDE STILE						
HAND	DESCRIPTION	FINISH CODE / DOOR PRICE				
		#10 CLEAR	#20 BRONZE	#81 WHITE	#2604 POWDER	#2605 POWDER
RH	3684WS-CO	\$700	\$728	\$728	\$846	\$892
LH	3684WS-DO	\$700	\$728	\$728	\$846	\$892
RH	4284WS-CO	\$734	\$757	\$757	\$888	\$936
LH	4284WS-DO	\$734	\$757	\$757	\$888	\$936
PAIR	7284WS-KO	\$1,429	\$1,487	\$1,487	\$1,713	\$1,802

Note: Add "DM001" to substitute DG101 Glass Stops used for 1" Insulated Glass.

Offset Pivot CVR Panic Frame Package Includes

- 1¾" or 2" x 4½" Open Back Frame
- Snap-in DS200 Door Stop w/pile
- ½" x 4" Threshold – Mill Finish
- Threshold Clips
- Bottom Frame Pivots
- Prepped for DH100 Top Pivot
- Prep for Lock Strike
- Prep for COC
- Frame assembly fastener package
- Applied DS202 Header Door stop

Note: All Hardware on Powder coat products is furnished in a standard clear finish.

Note: Standard Frame Height for Transom Frames = 10'-5 ½".

Order Number Example: 3684-DO-FT2 (Size) - (Hand or Pair) - (Type)

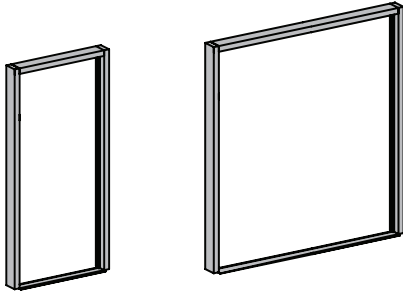

FL200 DOOR FRAME (Non-Transom)						
HAND	DESCRIPTION	FINISH CODE / FRAME PRICE				
		#10 CLEAR	#20 BRONZE	#81 WHITE	#2604 POWDER	#2605 POWDER
RH	3684-CO-F2	\$375	\$386	\$386	\$474	\$503
LH	3684-DO-F2	\$375	\$386	\$386	\$474	\$503
RH	4284-CO-F2	\$382	\$392	\$392	\$484	\$515
LH	4284-DO-F2	\$382	\$392	\$392	\$484	\$515
PAIR	7284-KO-F2	\$466	\$478	\$478	\$589	\$625

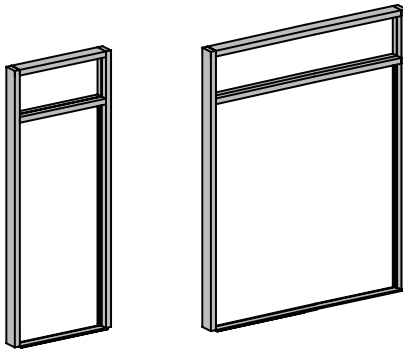

FL200 DOOR FRAME WITH TRANSOM						
HAND	DESCRIPTION	FINISH CODE / FRAME PRICE				
		#10 CLEAR	#20 BRONZE	#81 WHITE	#2604 POWDER	#2605 POWDER
RH	3684-CO-FT2	\$524	\$540	\$540	\$668	\$712
LH	3684-DO-FT2	\$524	\$540	\$540	\$668	\$712
RH	4284-CO-FT2	\$535	\$552	\$552	\$688	\$734
LH	4284-DO-FT2	\$535	\$552	\$552	\$688	\$734
PAIR	7284-KO-FT2	\$648	\$669	\$669	\$841	\$899

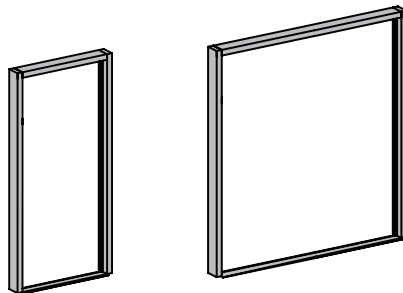

FL300 DOOR FRAME (Non-Transom)						
HAND	DESCRIPTION	FINISH CODE / FRAME PRICE				
		#10 CLEAR	#20 BRONZE	#81 WHITE	#2604 POWDER	#2605 POWDER
RH	3684-CO-F3	\$389	\$400	\$400	\$491	\$521
LH	3684-DO-F3	\$389	\$400	\$400	\$491	\$521
RH	4284-CO-F3	\$396	\$407	\$407	\$502	\$533
LH	4284-DO-F3	\$396	\$407	\$407	\$502	\$533
PAIR	7284-KO-F3	\$486	\$499	\$499	\$614	\$650

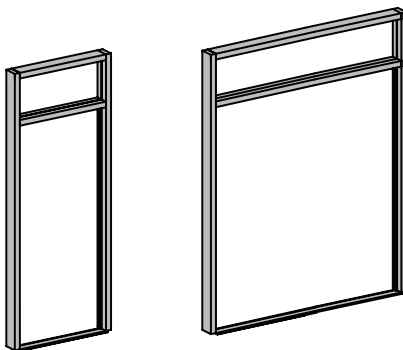

FL300 DOOR FRAME WITH TRANSOM						
HAND	DESCRIPTION	FINISH CODE / FRAME PRICE				
		#10 CLEAR	#20 BRONZE	#81 WHITE	#2604 POWDER	#2605 POWDER
RH	3684-CO-FT3	\$580	\$600	\$600	\$756	\$809
LH	3684-DO-FT3	\$580	\$600	\$600	\$756	\$809
RH	4284-CO-FT3	\$592	\$613	\$613	\$776	\$830
LH	4284-DO-FT3	\$592	\$613	\$613	\$776	\$830
PAIR	7284-KO-FT3	\$707	\$732	\$732	\$940	\$1,008

Entrances

Standard Doors • Offset Pivot/Offset Arm

Offset Pivot - Offset Arm Door Package Includes

- Traditional 1" rd Pull/Push Hardware
- Glass Stops for ¼" Glazing
- Top, Bottom, & Intermediate Door Pivots
- Slide Channel installed with Offset Arm
- MS Hook Bolt - Single or Active Leaf
- Top & Bottom Flush Bolts Inactive Leaf
- Keyed Cylinder Exterior
- Thumb Turn Interior

Note: Reference Hardware Section of the Price Catalog for Door Closers and Loose Hardware Items not included in Standard Entrance section.

Note: All Hardware on Powder coat products is furnished in a standard clear finish.

Note: D102 Top Rail on Narrow Stile Doors with offset arm. DH100 Intermediate pivot used as top pivot.

Order Number Example: 3696MS-DO (Size and Series) - (Hand or Pair)

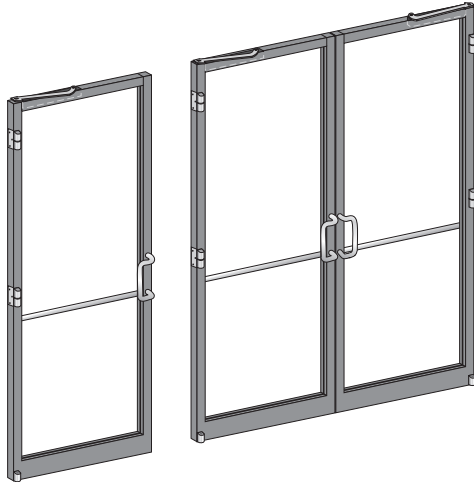

SERIES 213 NARROW STILE						
HAND	DESCRIPTION	FINISH CODE / DOOR PRICE				
		#10 CLEAR	#20 BRONZE	#81 WHITE	#2604 POWDER	#2605 POWDER
RH	3696-CO	\$675	\$704	\$704	\$807	\$848
LH	3696-DO	\$675	\$704	\$704	\$807	\$848
RH	4296-CO	\$710	\$734	\$734	\$849	\$892
LH	4296-DO	\$710	\$734	\$734	\$849	\$892
PAIR	7296-KO	\$1,384	\$1,443	\$1,443	\$1,622	\$1,698



SERIES 380 MEDIUM STILE						
HAND	DESCRIPTION	FINISH CODE / DOOR PRICE				
		#10 CLEAR	#20 BRONZE	#81 WHITE	#2604 POWDER	#2605 POWDER
RH	3696MS-CO	\$725	\$755	\$755	\$875	\$921
LH	3696MS-DO	\$725	\$755	\$755	\$875	\$921
RH	4296MS-CO	\$763	\$787	\$787	\$920	\$969
LH	4296MS-DO	\$763	\$787	\$787	\$920	\$969
PAIR	7296MS-KO	\$1,507	\$1,567	\$1,567	\$1,795	\$1,886



SERIES 500 WIDE STILE						
HAND	DESCRIPTION	FINISH CODE / DOOR PRICE				
		#10 CLEAR	#20 BRONZE	#81 WHITE	#2604 POWDER	#2605 POWDER
RH	3696WS-CO	\$778	\$808	\$808	\$942	\$992
LH	3696WS-DO	\$778	\$808	\$808	\$942	\$992
RH	4296WS-CO	\$816	\$840	\$840	\$987	\$1,041
LH	4296WS-DO	\$816	\$840	\$840	\$987	\$1,041
PAIR	7296WS-KO	\$1,590	\$1,651	\$1,651	\$1,906	\$2,005

Note: Add "DM001" to substitute DG101 Glass Stops used for 1" Insulated Glass.

Offset Pivot CVR Panic Frame Package Includes

- 1 1/4" or 2" x 4 1/2" Open Back Frame
- Snap-in DS200 Jamb Door Stop w/pile
- 1/2" x 4" Threshold – Mill Finish
- Applied DS202 Header Door stop

- Bottom Frame Pivots
- Prep for Lock Strike
- Prepped for DH100 Top Pivot
- Prep for Intermediate Pivots

- Prep for Top & Bottom Flush Bolts (pair)
- Prep for COC
- Frame assembly fastener package
- Threshold Clips

Note: All Hardware on Powder coat products is furnished in a standard clear finish.

Note: Standard Frame Height for Transom Frames = 10'-5 1/2".

Order Number Example: 3696-DO-FT2 (Size) - (Hand or Pair) - (Type)

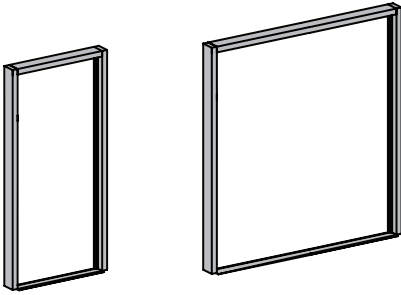

FL200 DOOR FRAME (Non-Transom)						
HAND	DESCRIPTION	FINISH CODE / FRAME PRICE				
		#10 CLEAR	#20 BRONZE	#81 WHITE	#2604 POWDER	#2605 POWDER
RH	3696-CO-F2	\$410	\$421	\$421	\$519	\$552
LH	3696-DO-F2	\$410	\$421	\$421	\$519	\$552
RH	4296-CO-F2	\$416	\$428	\$428	\$530	\$564
LH	4296-DO-F2	\$416	\$428	\$428	\$530	\$564
PAIR	7296-KO-F2	\$504	\$517	\$517	\$638	\$677

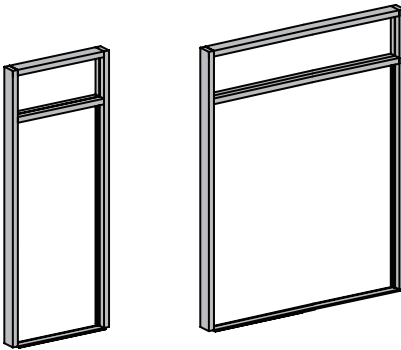

FL200 DOOR FRAME WITH TRANSM						
HAND	DESCRIPTION	FINISH CODE / FRAME PRICE				
		#10 CLEAR	#20 BRONZE	#81 WHITE	#2604 POWDER	#2605 POWDER
RH	3696-CO-FT2	\$543	\$560	\$560	\$692	\$736
LH	3696-DO-FT2	\$543	\$560	\$560	\$692	\$736
RH	4296-CO-FT2	\$554	\$572	\$572	\$711	\$758
LH	4296-DO-FT2	\$554	\$572	\$572	\$711	\$758
PAIR	7296-KO-FT2	\$671	\$692	\$692	\$869	\$927

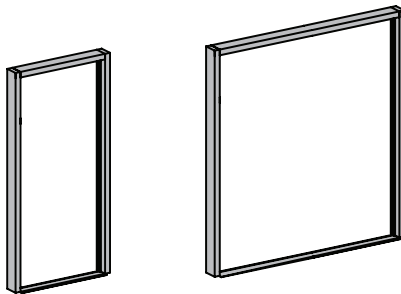

FL300 DOOR FRAME (Non-Transom)						
HAND	DESCRIPTION	FINISH CODE / FRAME PRICE				
		#10 CLEAR	#20 BRONZE	#81 WHITE	#2604 POWDER	#2605 POWDER
RH	3696-CO-F3	\$424	\$436	\$436	\$537	\$571
LH	3696-DO-F3	\$424	\$436	\$436	\$537	\$571
RH	4296-CO-F3	\$431	\$443	\$443	\$549	\$583
LH	4296-DO-F3	\$431	\$443	\$443	\$549	\$583
PAIR	7296-KO-F3	\$525	\$539	\$539	\$664	\$703

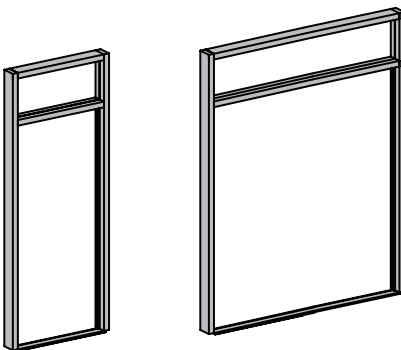

FL300 DOOR FRAME WITH TRANSM						
HAND	DESCRIPTION	FINISH CODE / FRAME PRICE				
		#10 CLEAR	#20 BRONZE	#81 WHITE	#2604 POWDER	#2605 POWDER
RH	3696-CO-FT3	\$590	\$610	\$610	\$761	\$812
LH	3696-DO-FT3	\$590	\$610	\$610	\$761	\$812
RH	4296-CO-FT3	\$602	\$622	\$622	\$780	\$833
LH	4296-DO-FT3	\$602	\$622	\$622	\$780	\$833
PAIR	7296-KO-FT3	\$721	\$745	\$745	\$949	\$1,015

Entrances

Standard Doors • Offset Pivot/Panic/Offset Arm

Offset Pivot – CVR Panic – Offset Arm Door Package Includes

- Traditional 1" rd Pull/Push Hardware
- Glass Stops for ¼" Glazing
- Top & Bottom Door Pivots
- Slide Channel installed with Offset Arm
- DH3692 CVR Touch Bar Panic(s)
- Keyed Cylinder Exterior - Single or Active Leaf

Note: Reference Hardware Section of the Price Catalog for Door Closers and Loose Hardware Items not included in Standard Entrance section.

Note: All Hardware on Powder coat products is furnished in a standard clear finish.

Note: D102 Top Rail on Narrow Stile Doors with offset arm. DH100 Intermediate pivot used as top pivot.

Order Number Example: **3684MS-DOP** (Size and Series) - (Hand or Pair)

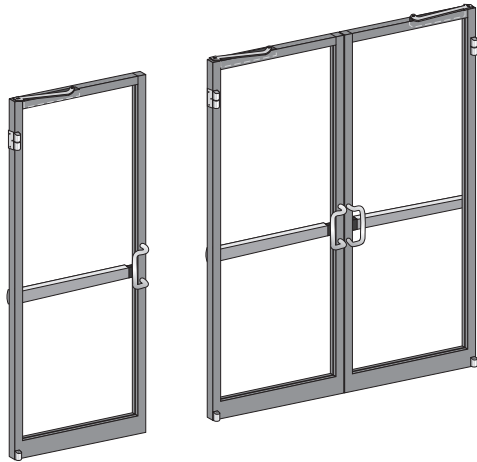

SERIES 213 NARROW STILE						
HAND	DESCRIPTION	FINISH CODE / DOOR PRICE				
		#10 CLEAR	#20 BRONZE	#81 WHITE	#2604 POWDER	#2605 POWDER
RH	3684-COP	\$885	\$905	\$905	\$1,004	\$1,041
LH	3684-DOP	\$885	\$905	\$905	\$1,004	\$1,041
RH	4284-COP	\$905	\$926	\$926	\$1,031	\$1,070
LH	4284-DOP	\$905	\$926	\$926	\$1,031	\$1,070
PAIR	7284-KOP	\$1,803	\$1,844	\$1,844	\$2,018	\$2,087



SERIES 380 MEDIUM STILE						
HAND	DESCRIPTION	FINISH CODE / DOOR PRICE				
		#10 CLEAR	#20 BRONZE	#81 WHITE	#2604 POWDER	#2605 POWDER
RH	3684MS-COP	\$930	\$950	\$950	\$1,064	\$1,106
LH	3684MS-DOP	\$930	\$950	\$950	\$1,064	\$1,106
RH	4284MS-COP	\$953	\$974	\$974	\$1,095	\$1,140
LH	4284MS-DOP	\$953	\$974	\$974	\$1,095	\$1,140
PAIR	7284MS-KOP	\$1,914	\$1,957	\$1,957	\$2,174	\$2,257



SERIES 500 WIDE STILE						
HAND	DESCRIPTION	FINISH CODE / DOOR PRICE				
		#10 CLEAR	#20 BRONZE	#81 WHITE	#2604 POWDER	#2605 POWDER
RH	3684WS-COP	\$979	\$1,000	\$1,000	\$1,125	\$1,171
LH	3684WS-DOP	\$979	\$1,000	\$1,000	\$1,125	\$1,171
RH	4284WS-COP	\$1,002	\$1,024	\$1,024	\$1,156	\$1,204
LH	4284WS-DOP	\$1,002	\$1,024	\$1,024	\$1,156	\$1,204
PAIR	7284WS-KOP	\$1,990	\$2,033	\$2,033	\$2,273	\$2,362

Note: Add "DM001" to substitute DG101 Glass Stops used for 1" Insulated Glass.

Offset Pivot – CVR Panic – Offset Arm Frame Package Includes

- 1¼" or 2" x 4½" Open Back Frame
- Snap-in DS200 Jamb Door Stop w/pile
- Applied DS202 Header Door stop
- ½" x 4" Threshold – Mill Finish
- Bottom Frame Pivots
- Prepped for DH100 Top Pivot
- Prep for DH3692 CVR Panic(s)
- Threshold Clips
- Prep for Intermediate Pivots
- Prep for COC
- Frame assembly fastener package

Note: All Hardware on Powder coat products is furnished in a standard clear finish.

Note: Standard Frame Height for Transom Frames = 10'-5 ½".

Order Number Example: **3684-DOP-FT2** (Size) - (Hand or Pair) - (Type)

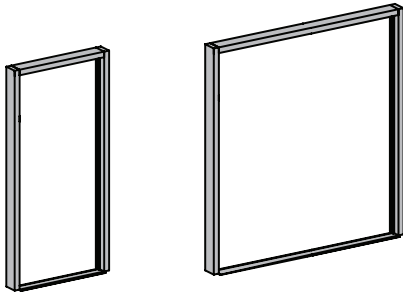

FL200 DOOR FRAME (Non-Transom)						
HAND	DESCRIPTION	FINISH CODE / FRAME PRICE				
		#10 CLEAR	#20 BRONZE	#81 WHITE	#2604 POWDER	#2605 POWDER
RH	3684-COP-F2	\$389	\$399	\$399	\$488	\$517
LH	3684-DOP-F2	\$389	\$399	\$399	\$488	\$517
RH	4284-COP-F2	\$395	\$406	\$406	\$498	\$528
LH	4284-DOP-F2	\$395	\$406	\$406	\$498	\$528
PAIR	7284-KOP-F2	\$479	\$490	\$490	\$602	\$637

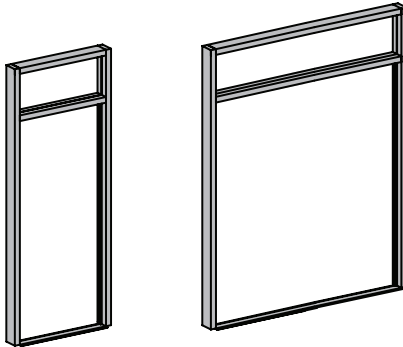

FL200 DOOR FRAME WITH TRANSOM						
HAND	DESCRIPTION	FINISH CODE / FRAME PRICE				
		#10 CLEAR	#20 BRONZE	#81 WHITE	#2604 POWDER	#2605 POWDER
RH	3684-COP-FT2	\$537	\$554	\$554	\$682	\$725
LH	3684-DOP-FT2	\$537	\$554	\$554	\$682	\$725
RH	4284-COP-FT2	\$549	\$566	\$566	\$702	\$748
LH	4284-DOP-FT2	\$549	\$566	\$566	\$702	\$748
PAIR	7284-KOP-FT2	\$661	\$681	\$681	\$854	\$911

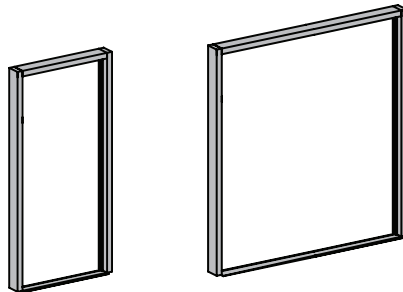

FL300 DOOR FRAME (Non-Transom)						
HAND	DESCRIPTION	FINISH CODE / FRAME PRICE				
		#10 CLEAR	#20 BRONZE	#81 WHITE	#2604 POWDER	#2605 POWDER
RH	3684-COP-F3	\$402	\$413	\$413	\$504	\$534
LH	3684-DOP-F3	\$402	\$413	\$413	\$504	\$534
RH	4284-COP-F3	\$410	\$421	\$421	\$516	\$547
LH	4284-DOP-F3	\$410	\$421	\$421	\$516	\$547
PAIR	7284-KOP-F3	\$499	\$511	\$511	\$626	\$663

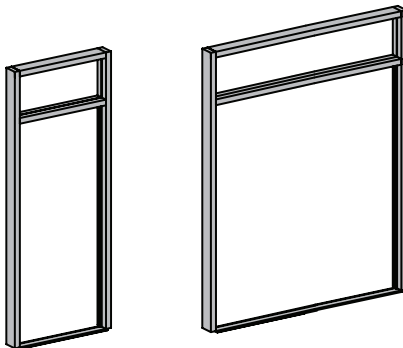

FL300 DOOR FRAME WITH TRANSOM						
HAND	DESCRIPTION	FINISH CODE / FRAME PRICE				
		#10 CLEAR	#20 BRONZE	#81 WHITE	#2604 POWDER	#2605 POWDER
RH	3684-COP-FT3	\$593	\$613	\$613	\$769	\$822
LH	3684-DOP-FT3	\$593	\$613	\$613	\$769	\$822
RH	4284-COP-FT3	\$605	\$626	\$626	\$789	\$844
LH	4284-DOP-FT3	\$605	\$626	\$626	\$789	\$844
PAIR	7284-KOP-FT3	\$720	\$744	\$744	\$953	\$1,021

Entrances

Standard Doors • Offset Pivot/Panic/Offset Arm

Offset Pivot – CVR Panic – Offset Arm Door Package Includes

- Traditional 1" rd Pull/Push Hardware
- Glass Stops for ¾" Glazing
- Top, Bottom & Intermediate Door Pivots
- Slide Channel installed with Offset Arm
- DH3692 CVR Touch Bar Panic(s)
- Keyed Cylinder Exterior - Single or Active Leaf

Note: Reference Hardware Section of the Price Catalog for Door Closers and Loose Hardware Items not included in Standard Entrance section.

Note: All Hardware on Powder coat products is furnished in a standard clear finish.

Note: D102 Top Rail on Narrow Stile Doors with offset arm. DH100 Intermediate pivot used as top pivot.

Order Number Example: 3696MS-DOP (Size and Series) - (Hand or Pair)

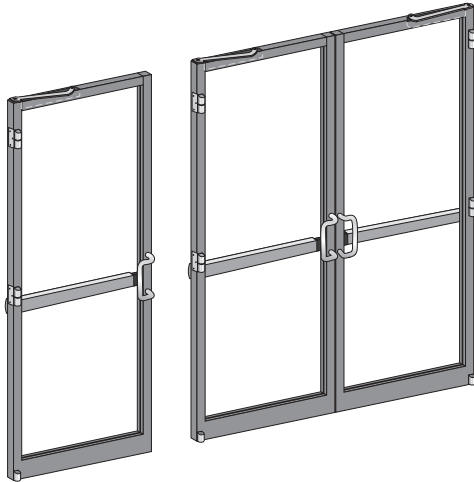

SERIES 213 NARROW STILE						
HAND	DESCRIPTION	FINISH CODE / DOOR PRICE				
		#10 CLEAR	#20 BRONZE	#81 WHITE	#2604 POWDER	#2605 POWDER
RH	3696-COP	\$955	\$976	\$976	\$1,086	\$1,127
LH	3696-DOP	\$955	\$976	\$976	\$1,086	\$1,127
RH	4296-COP	\$978	\$1,000	\$1,000	\$1,116	\$1,160
LH	4296-DOP	\$978	\$1,000	\$1,000	\$1,116	\$1,160
PAIR	7296-KOP	\$1,946	\$1,991	\$1,991	\$2,184	\$2,261



SERIES 380 MEDIUM STILE						
HAND	DESCRIPTION	FINISH CODE / DOOR PRICE				
		#10 CLEAR	#20 BRONZE	#81 WHITE	#2604 POWDER	#2605 POWDER
RH	3696MS-COP	\$1,005	\$1,027	\$1,027	\$1,154	\$1,200
LH	3696MS-DOP	\$1,005	\$1,027	\$1,027	\$1,154	\$1,200
RH	4296MS-COP	\$1,030	\$1,053	\$1,053	\$1,188	\$1,237
LH	4296MS-DOP	\$1,030	\$1,053	\$1,053	\$1,188	\$1,237
PAIR	7296MS-KOP	\$2,067	\$2,113	\$2,113	\$2,355	\$2,446



SERIES 500 WIDE STILE						
HAND	DESCRIPTION	FINISH CODE / DOOR PRICE				
		#10 CLEAR	#20 BRONZE	#81 WHITE	#2604 POWDER	#2605 POWDER
RH	3696WS-COP	\$1,058	\$1,080	\$1,080	\$1,221	\$1,271
LH	3696WS-DOP	\$1,058	\$1,080	\$1,080	\$1,221	\$1,271
RH	4296WS-COP	\$1,083	\$1,107	\$1,107	\$1,255	\$1,308
LH	4296WS-DOP	\$1,083	\$1,107	\$1,107	\$1,255	\$1,308
PAIR	7296WS-KOP	\$2,150	\$2,197	\$2,197	\$2,465	\$2,565

Note: Add "DM001" to substitute DG101 Glass Stops used for 1" Insulated Glass.

Offset Pivot – CVR Panic – Offset Arm Frame Package Includes

- 1 1/4" or 2" x 4 1/2" Open Back Frame
- Snap-in DS200 Jamb Door Stop w/pile
- Applied DS202 Header Door stop
- 1/2" x 4" Threshold – Mill Finish
- Threshold Clips
- Prepped for DH100 Top Pivot
- Bottom Frame Pivots
- Prep for DH3692 CVR Panic(s)
- Prep for Intermediate Pivots
- Prep for COC
- Frame assembly fastener package

Note: All Hardware on Powder coat products is furnished in a standard clear finish.

Note: Standard Frame Height for Transom Frames = 10'-5 1/4".

Order Number Example: 3696-DOP-FT2 (Size) - (Hand or Pair) - (Type)

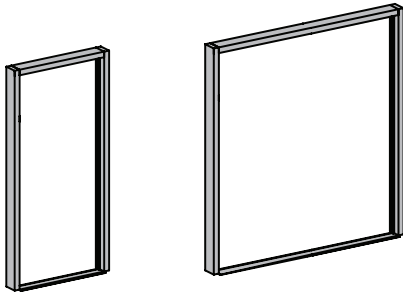

FL200 DOOR FRAME (Non-Transom)						
HAND	DESCRIPTION	FINISH CODE / FRAME PRICE				
		#10 CLEAR	#20 BRONZE	#81 WHITE	#2604 POWDER	#2605 POWDER
RH	3696-COP-F2	\$423	\$435	\$435	\$533	\$565
LH	3696-DOP-F2	\$423	\$435	\$435	\$533	\$565
RH	4296-COP-F2	\$429	\$441	\$441	\$543	\$577
LH	4296-DOP-F2	\$429	\$441	\$441	\$543	\$577
PAIR	7296-KOP-F2	\$517	\$530	\$530	\$651	\$690

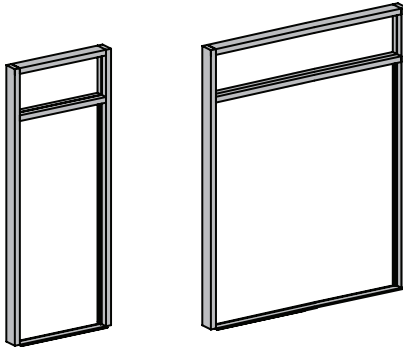

FL200 DOOR FRAME WITH TRANSOM						
HAND	DESCRIPTION	FINISH CODE / FRAME PRICE				
		#10 CLEAR	#20 BRONZE	#81 WHITE	#2604 POWDER	#2605 POWDER
RH	3696-COP-FT2	\$556	\$573	\$573	\$705	\$750
LH	3696-DOP-FT2	\$556	\$573	\$573	\$705	\$750
RH	4296-COP-FT2	\$568	\$585	\$585	\$725	\$772
LH	4296-DOP-FT2	\$568	\$585	\$585	\$725	\$772
PAIR	7296-KOP-FT2	\$684	\$705	\$705	\$882	\$940

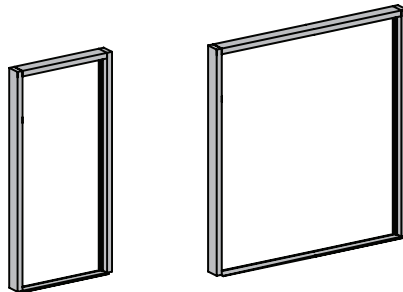

FL300 DOOR FRAME (Non-Transom)						
HAND	DESCRIPTION	FINISH CODE / FRAME PRICE				
		#10 CLEAR	#20 BRONZE	#81 WHITE	#2604 POWDER	#2605 POWDER
RH	3696-COP-F3	\$437	\$449	\$449	\$551	\$584
LH	3696-DOP-F3	\$437	\$449	\$449	\$551	\$584
RH	4296-COP-F3	\$444	\$457	\$457	\$562	\$597
LH	4296-DOP-F3	\$444	\$457	\$457	\$562	\$597
PAIR	7296-KOP-F3	\$538	\$552	\$552	\$676	\$716

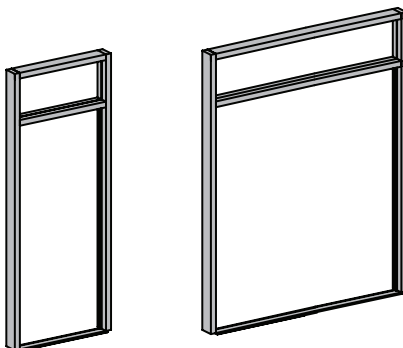

FL300 DOOR FRAME WITH TRANSOM						
HAND	DESCRIPTION	FINISH CODE / FRAME PRICE				
		#10 CLEAR	#20 BRONZE	#81 WHITE	#2604 POWDER	#2605 POWDER
RH	3696-COP-FT3	\$603	\$623	\$623	\$774	\$825
LH	3696-DOP-FT3	\$603	\$623	\$623	\$774	\$825
RH	4296-COP-FT3	\$615	\$636	\$636	\$794	\$847
LH	4296-DOP-FT3	\$615	\$636	\$636	\$794	\$847
PAIR	7296-KOP-FT3	\$734	\$758	\$758	\$962	\$1,028

Entrances

Standard Doors • Butt Hinge

Butt Hinge Door Package Includes

- Traditional 1" rd Pull/Push Hardware
- Glass Stops for ¼" Glazing
- One Pair 4½" x 4" Butt Hinges
- MS Hook Bolt - Single or Active Leaf
- Top & Bottom Flush Bolts Inactive Leaf
- Keyed Cylinder Exterior
- Thumb Turn Interior

Note: Reference Hardware Section of the Price Catalog for Door Closers and Loose Hardware Items not included in Standard Entrance section.

Note: All Hardware on Powder coat products is furnished in a standard clear finish.

Order Number Example: **3684MS-B** (Size and Series) - (Hand or Pair)



SERIES 213 NARROW STILE						
HAND	DESCRIPTION	FINISH CODE / DOOR PRICE				
		#10 CLEAR	#20 BRONZE	#81 WHITE	#2604 POWDER	#2605 POWDER
RH	3684-A	\$502	\$529	\$529	\$618	\$654
LH	3684-B	\$502	\$529	\$529	\$618	\$654
RH	4284-A	\$532	\$555	\$555	\$654	\$692
LH	4284-B	\$532	\$555	\$555	\$654	\$692
PAIR	7284-J	\$1,027	\$1,083	\$1,083	\$1,237	\$1,305



SERIES 380 MEDIUM STILE						
HAND	DESCRIPTION	FINISH CODE / DOOR PRICE				
		#10 CLEAR	#20 BRONZE	#81 WHITE	#2604 POWDER	#2605 POWDER
RH	3684MS-A	\$554	\$582	\$582	\$689	\$731
LH	3684MS-B	\$554	\$582	\$582	\$689	\$731
RH	4284MS-A	\$588	\$611	\$611	\$731	\$776
LH	4284MS-B	\$588	\$611	\$611	\$731	\$776
PAIR	7284MS-J	\$1,132	\$1,190	\$1,190	\$1,392	\$1,475



SERIES 500 WIDE STILE						
HAND	DESCRIPTION	FINISH CODE / DOOR PRICE				
		#10 CLEAR	#20 BRONZE	#81 WHITE	#2604 POWDER	#2605 POWDER
RH	3684WS-A	\$592	\$620	\$620	\$738	\$784
LH	3684WS-B	\$592	\$620	\$620	\$738	\$784
RH	4284WS-A	\$626	\$649	\$649	\$780	\$828
LH	4284WS-B	\$626	\$649	\$649	\$780	\$828
PAIR	7284WS-J	\$1,207	\$1,266	\$1,266	\$1,491	\$1,580

Note: Add "DM001" to substitute DG101 Glass Stops used for 1" Insulated Glass.

Butt Hinge Frame Package Includes

- 1¾" or 2" x 4½" Open Back Frame
- Snap-in DS200 Door Stop w/pile
- ½" x 4" Threshold – Mill Finish

- Threshold Clips
- Prep for Lock Strike
- Prep for One Pair 4½" x 4" Butt Hinges

- Prep for Top & Bottom Flush Bolts (pair)
- Frame assembly fastener package

Note: All Hardware on Powder coat products is furnished in a standard clear finish.

Note: Standard Frame Height for Transom Frames = 10'-5 ½".

Order Number Example: 3684-B-FT2 (Size) - (Hand or Pair) - (Type)

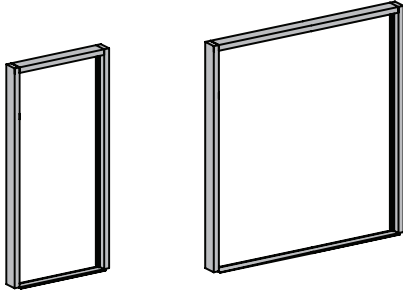

FL200 DOOR FRAME (Non-Transom)						
HAND	DESCRIPTION	FINISH CODE / FRAME PRICE				
		#10 CLEAR	#20 BRONZE	#81 WHITE	#2604 POWDER	#2605 POWDER
RH	3684-A-F2	\$297	\$308	\$308	\$388	\$416
LH	3684-B-F2	\$297	\$308	\$308	\$388	\$416
RH	4284-A-F2	\$304	\$315	\$315	\$397	\$427
LH	4284-B-F2	\$304	\$315	\$315	\$397	\$427
PAIR	7284-J-F2	\$353	\$365	\$365	\$460	\$494

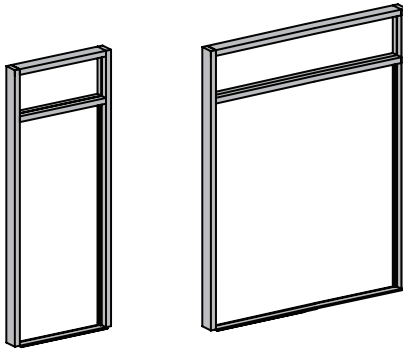

FL200 DOOR FRAME WITH TRANSOM						
HAND	DESCRIPTION	FINISH CODE / FRAME PRICE				
		#10 CLEAR	#20 BRONZE	#81 WHITE	#2604 POWDER	#2605 POWDER
RH	3684-A-FT2	\$411	\$427	\$427	\$530	\$569
LH	3684-B-FT2	\$411	\$427	\$427	\$530	\$569
RH	4284-A-FT2	\$421	\$437	\$437	\$545	\$585
LH	4284-B-FT2	\$421	\$437	\$437	\$545	\$585
PAIR	7284-J-FT2	\$493	\$512	\$512	\$647	\$695

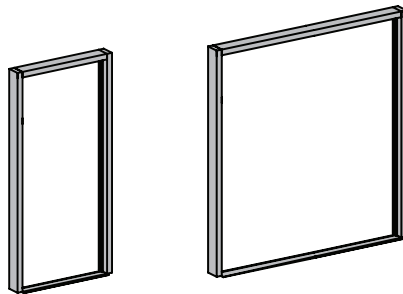

FL300 DOOR FRAME (Non-Transom)						
HAND	DESCRIPTION	FINISH CODE / FRAME PRICE				
		#10 CLEAR	#20 BRONZE	#81 WHITE	#2604 POWDER	#2605 POWDER
RH	3684-A-F3	\$304	\$316	\$316	\$396	\$426
LH	3684-B-F3	\$304	\$316	\$316	\$396	\$426
RH	4284-A-F3	\$311	\$322	\$322	\$407	\$437
LH	4284-B-F3	\$311	\$322	\$322	\$407	\$437
PAIR	7284-J-F3	\$364	\$377	\$377	\$472	\$507

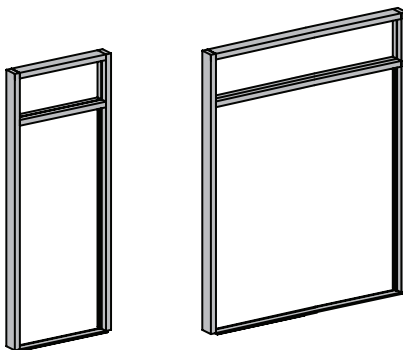

FL300 DOOR FRAME WITH TRANSOM						
HAND	DESCRIPTION	FINISH CODE / FRAME PRICE				
		#10 CLEAR	#20 BRONZE	#81 WHITE	#2604 POWDER	#2605 POWDER
RH	3684-A-FT3	\$444	\$464	\$464	\$599	\$648
LH	3684-B-FT3	\$444	\$464	\$464	\$599	\$648
RH	4284-A-FT3	\$454	\$474	\$474	\$614	\$664
LH	4284-B-FT3	\$454	\$474	\$474	\$614	\$664
PAIR	7284-J-FT3	\$523	\$546	\$546	\$716	\$774

Entrances

Standard Doors • Butt Hinge

Butt Hinge Door Package Includes

- Traditional 1" rd Pull/Push Hardware
- Glass Stops for ¾" Glazing
- 1½ Pair 4½" x 4" Butt Hinges
- MS Hook Bolt - Single or Active Leaf
- Top & Bottom Flush Bolts Inactive Leaf
- Keyed Cylinder Exterior
- Thumb Turn Interior

*Note: Reference Hardware Section of the Price Catalog for Door Closers and Loose Hardware Items not included in Standard Entrance section.
Note: All Hardware on Powder coat products is furnished in a standard clear finish.*

Order Number Example: **3696MS-A** (Size and Series) - (Hand or Pair)



SERIES 213 NARROW STILE						
HAND	DESCRIPTION	FINISH CODE / DOOR PRICE				
		#10 CLEAR	#20 BRONZE	#81 WHITE	#2604 POWDER	#2605 POWDER
RH	3696-A	\$546	\$575	\$575	\$675	\$715
LH	3696-B	\$546	\$575	\$575	\$675	\$715
RH	4296-A	\$580	\$604	\$604	\$715	\$757
LH	4296-B	\$580	\$604	\$604	\$715	\$757
PAIR	7296-J	\$1,120	\$1,179	\$1,179	\$1,352	\$1,426



SERIES 380 MEDIUM STILE						
HAND	DESCRIPTION	FINISH CODE / DOOR PRICE				
		#10 CLEAR	#20 BRONZE	#81 WHITE	#2604 POWDER	#2605 POWDER
RH	3696MS-A	\$604	\$633	\$633	\$753	\$800
LH	3696MS-B	\$604	\$633	\$633	\$753	\$800
RH	4296MS-A	\$641	\$666	\$666	\$798	\$847
LH	4296MS-B	\$641	\$666	\$666	\$798	\$847
PAIR	7296MS-J	\$1,235	\$1,296	\$1,296	\$1,523	\$1,614



SERIES 500 WIDE STILE						
HAND	DESCRIPTION	FINISH CODE / DOOR PRICE				
		#10 CLEAR	#20 BRONZE	#81 WHITE	#2604 POWDER	#2605 POWDER
RH	3696WS-A	\$645	\$676	\$676	\$809	\$859
LH	3696WS-B	\$645	\$676	\$676	\$809	\$859
RH	4296WS-A	\$683	\$708	\$708	\$854	\$908
LH	4296WS-B	\$683	\$708	\$708	\$854	\$908
PAIR	7296WS-J	\$1,318	\$1,380	\$1,380	\$1,634	\$1,733

Note: Add "DM001" to substitute DG101 Glass Stops used for 1" Insulated Glass.

Butt Hinge Frame Package Includes

- 1½" or 2" x 4½" Open Back Frame
- Snap-in DS200 Door Stop w/pile
- ½" x 4" Threshold – Mill Finish
- Threshold Clips
- Prep for Lock Strike
- Prep for 1½ Pair 4½" x 4" Butt Hinges
- Prep for Top & Bottom Flush Bolts (pair)
- Frame assembly fastener package

Note: All Hardware on Powder coat products is furnished in a standard clear finish.

Note: Standard Frame Height for Transom Frames = 10'-5 ½".

Order Number Example: 3696-A-FT2 (Size) - (Hand or Pair) - (Type)

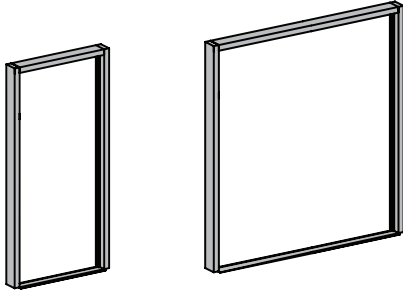

FL200 DOOR FRAME (Non-Transom)						
HAND	DESCRIPTION	FINISH CODE / FRAME PRICE				
		#10 CLEAR	#20 BRONZE	#81 WHITE	#2604 POWDER	#2605 POWDER
RH	3696-A-F2	\$328	\$340	\$340	\$430	\$461
LH	3696-B-F2	\$328	\$340	\$340	\$430	\$461
RH	4296-A-F2	\$335	\$347	\$347	\$439	\$472
LH	4296-B-F2	\$335	\$347	\$347	\$439	\$472
PAIR	7296-J-F2	\$387	\$401	\$401	\$510	\$547

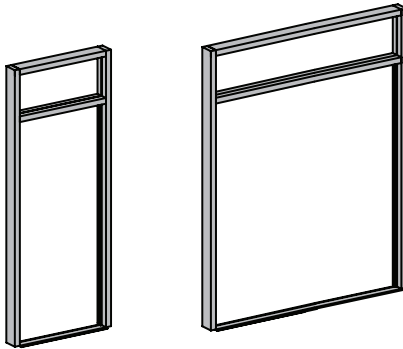

FL200 DOOR FRAME WITH TRANSOM						
HAND	DESCRIPTION	FINISH CODE / FRAME PRICE				
		#10 CLEAR	#20 BRONZE	#81 WHITE	#2604 POWDER	#2605 POWDER
RH	3696-A-FT2	\$427	\$443	\$443	\$550	\$590
LH	3696-B-FT2	\$427	\$443	\$443	\$550	\$590
RH	4296-A-FT2	\$437	\$453	\$453	\$565	\$607
LH	4296-B-FT2	\$437	\$453	\$453	\$565	\$607
PAIR	7296-J-FT2	\$512	\$532	\$532	\$665	\$714

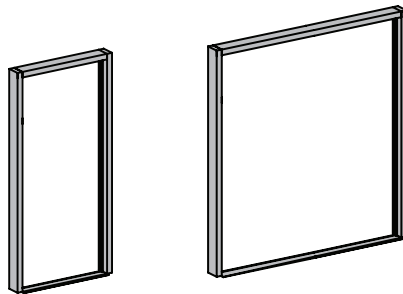

FL300 DOOR FRAME (Non-Transom)						
HAND	DESCRIPTION	FINISH CODE / FRAME PRICE				
		#10 CLEAR	#20 BRONZE	#81 WHITE	#2604 POWDER	#2605 POWDER
RH	3696-A-F3	\$336	\$349	\$349	\$440	\$472
LH	3696-B-F3	\$336	\$349	\$349	\$440	\$472
RH	4296-A-F3	\$343	\$355	\$355	\$450	\$483
LH	4296-B-F3	\$343	\$355	\$355	\$450	\$483
PAIR	7296-J-F3	\$399	\$414	\$414	\$523	\$561

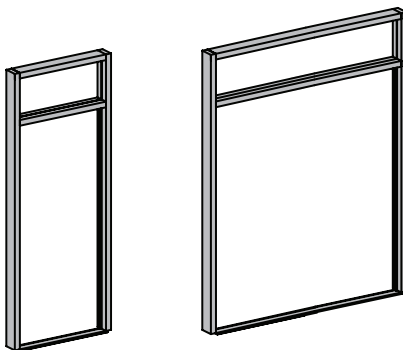

FL300 DOOR FRAME WITH TRANSOM						
HAND	DESCRIPTION	FINISH CODE / FRAME PRICE				
		#10 CLEAR	#20 BRONZE	#81 WHITE	#2604 POWDER	#2605 POWDER
RH	3696-A-FT3	\$451	\$470	\$470	\$601	\$648
LH	3696-B-FT3	\$451	\$470	\$470	\$601	\$648
RH	4296-A-FT3	\$461	\$480	\$480	\$615	\$664
LH	4296-B-FT3	\$461	\$480	\$480	\$615	\$664
PAIR	7296-J-FT3	\$534	\$556	\$556	\$714	\$771

Entrances

Standard Doors • Butt Hinge/Panic

Butt Hinge CVR Panic Door Package Includes

- Traditional 1" rd Pull/Push Hardware
- Glass Stops for ¼" Glazing
- One Pair 4½" x 4" Butt Hinges
- DH3692 CVR Touch Bar Panic(s)
- Keyed Cylinder Exterior - Single or Active Leaf

*Note: Reference Hardware Section of the Price Catalog for Door Closers and Loose Hardware Items not included in Standard Entrance section.
Note: All Hardware on Powder coat products is furnished in a standard clear finish.*

Order Number Example: **3684MS-BP** (Size and Series) - (Hand or Pair)



SERIES 213 NARROW STILE						
HAND	DESCRIPTION	FINISH CODE / DOOR PRICE				
		#10 CLEAR	#20 BRONZE	#81 WHITE	#2604 POWDER	#2605 POWDER
RH	3684-AP	\$781	\$801	\$801	\$897	\$933
LH	3684-BP	\$781	\$801	\$801	\$897	\$933
RH	4284-AP	\$800	\$821	\$821	\$922	\$960
LH	4284-BP	\$800	\$821	\$821	\$922	\$960
PAIR	7284-JP	\$1,589	\$1,631	\$1,631	\$1,799	\$1,867



SERIES 380 MEDIUM STILE						
HAND	DESCRIPTION	FINISH CODE / DOOR PRICE				
		#10 CLEAR	#20 BRONZE	#81 WHITE	#2604 POWDER	#2605 POWDER
RH	3684MS-AP	\$833	\$854	\$854	\$968	\$1,010
LH	3684MS-BP	\$833	\$854	\$854	\$968	\$1,010
RH	4284MS-AP	\$856	\$878	\$878	\$999	\$1,043
LH	4284MS-BP	\$856	\$878	\$878	\$999	\$1,043
PAIR	7284MS-JP	\$1,692	\$1,735	\$1,735	\$1,952	\$2,035



SERIES 500 WIDE STILE						
HAND	DESCRIPTION	FINISH CODE / DOOR PRICE				
		#10 CLEAR	#20 BRONZE	#81 WHITE	#2604 POWDER	#2605 POWDER
RH	3684WS-AP	\$871	\$892	\$892	\$1,017	\$1,063
LH	3684WS-BP	\$871	\$892	\$892	\$1,017	\$1,063
RH	4284WS-AP	\$894	\$916	\$916	\$1,048	\$1,096
LH	4284WS-BP	\$894	\$916	\$916	\$1,048	\$1,096
PAIR	7284WS-JP	\$1,767	\$1,811	\$1,811	\$2,050	\$2,140

Note: Add "DM001" to substitute DG101 Glass Stops used for 1" Insulated Glass.

Butt Hinge CVR Panic Frame Package Includes

- 1 3/4" or 2" x 4 1/2" Open Back Frame
- Snap-in DS200 Door Stop w/pile
- 1/2" x 4" Threshold – Mill Finish
- Threshold Clips
- Prep for One Pair 4 1/2" x 4" Butt Hinges
- Prep for DH3692 CVR Panic(s)
- Frame assembly fastener package

Note: All Hardware on Powder coat products is furnished in a standard clear finish.

Note: Standard Frame Height for Transom Frames = 10'-5 1/2".

Order Number Example: **3684-BP-FT2** (Size) - (Hand or Pair) - (Type)

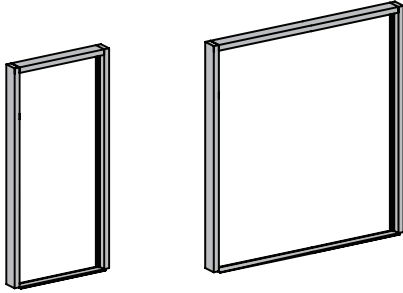

FL200 DOOR FRAME (Non-Transom)						
HAND	DESCRIPTION	FINISH CODE / FRAME PRICE				
		#10 CLEAR	#20 BRONZE	#81 WHITE	#2604 POWDER	#2605 POWDER
RH	3684-AP-F2	\$311	\$322	\$322	\$401	\$430
LH	3684-BP-F2	\$311	\$322	\$322	\$401	\$430
RH	4284-AP-F2	\$317	\$328	\$328	\$411	\$440
LH	4284-BP-F2	\$317	\$328	\$328	\$411	\$440
PAIR	7284-JP-F2	\$366	\$379	\$379	\$478	\$512

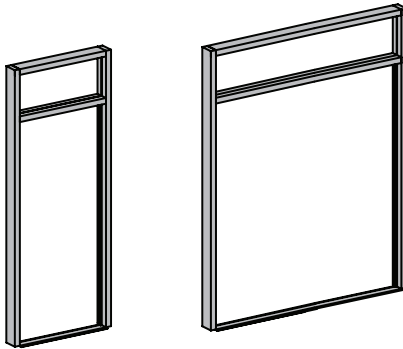

FL200 DOOR FRAME WITH TRANSOM						
HAND	DESCRIPTION	FINISH CODE / FRAME PRICE				
		#10 CLEAR	#20 BRONZE	#81 WHITE	#2604 POWDER	#2605 POWDER
RH	3684-AP-FT2	\$424	\$440	\$440	\$544	\$583
LH	3684-BP-FT2	\$424	\$440	\$440	\$544	\$583
RH	4284-AP-FT2	\$435	\$451	\$451	\$559	\$599
LH	4284-BP-FT2	\$435	\$451	\$451	\$559	\$599
PAIR	7284-JP-FT2	\$506	\$526	\$526	\$655	\$703

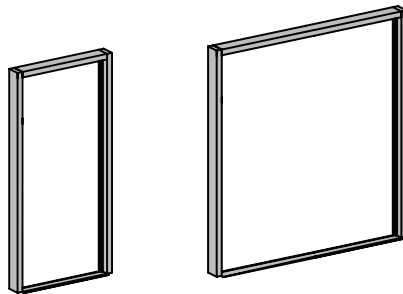

FL300 DOOR FRAME (Non-Transom)						
HAND	DESCRIPTION	FINISH CODE / FRAME PRICE				
		#10 CLEAR	#20 BRONZE	#81 WHITE	#2604 POWDER	#2605 POWDER
RH	3684-AP-F3	\$318	\$329	\$329	\$410	\$439
LH	3684-BP-F3	\$318	\$329	\$329	\$410	\$439
RH	4284-AP-F3	\$325	\$336	\$336	\$420	\$450
LH	4284-BP-F3	\$325	\$336	\$336	\$420	\$450
PAIR	7284-JP-F3	\$378	\$391	\$391	\$490	\$525

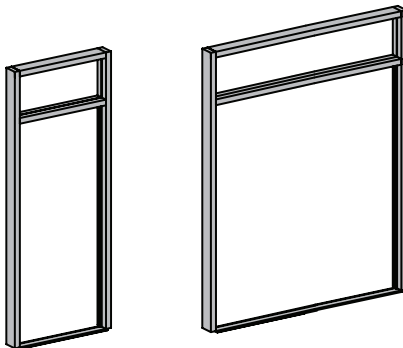

FL300 DOOR FRAME WITH TRANSOM						
HAND	DESCRIPTION	FINISH CODE / FRAME PRICE				
		#10 CLEAR	#20 BRONZE	#81 WHITE	#2604 POWDER	#2605 POWDER
RH	3684-AP-FT3	\$458	\$477	\$477	\$613	\$661
LH	3684-BP-FT3	\$458	\$477	\$477	\$613	\$661
RH	4284-AP-FT3	\$467	\$487	\$487	\$628	\$678
LH	4284-BP-FT3	\$467	\$487	\$487	\$628	\$678
PAIR	7284-JP-FT3	\$537	\$560	\$560	\$723	\$781

Entrances

Standard Doors • Butt Hinge/Panic

Butt Hinge CVR Panic Door Package Includes

- Traditional 1" rd Pull/Push Hardware
- Glass Stops for ¼" Glazing
- 1½ Pair 4½" x 4" Butt Hinges
- Keyed Cylinder Exterior - Single or Active Leaf
- DH3692 CVR Touch Bar Panic(s)

*Note: Reference Hardware Section of the Price Catalog for Door Closers and Loose Hardware Items not included in Standard Entrance section.
Note: All Hardware on Powder coat products is furnished in a standard clear finish.*

Order Number Example: 3696MS-BP (Size and Series) - (Hand or Pair)



SERIES 213 NARROW STILE						
HAND	DESCRIPTION	FINISH CODE / DOOR PRICE				
		#10 CLEAR	#20 BRONZE	#81 WHITE	#2604 POWDER	#2605 POWDER
RH	3696-AP	\$825	\$847	\$847	\$954	\$994
LH	3696-BP	\$825	\$847	\$847	\$954	\$994
RH	4296-AP	\$848	\$870	\$870	\$982	\$1,024
LH	4296-BP	\$848	\$870	\$870	\$982	\$1,024
PAIR	7296-JP	\$1,682	\$1,727	\$1,727	\$1,914	\$1,988



SERIES 380 MEDIUM STILE						
HAND	DESCRIPTION	FINISH CODE / DOOR PRICE				
		#10 CLEAR	#20 BRONZE	#81 WHITE	#2604 POWDER	#2605 POWDER
RH	3696MS-AP	\$883	\$905	\$905	\$1,032	\$1,079
LH	3696MS-BP	\$883	\$905	\$905	\$1,032	\$1,079
RH	4296MS-AP	\$909	\$932	\$932	\$1,066	\$1,115
LH	4296MS-BP	\$909	\$932	\$932	\$1,066	\$1,115
PAIR	7296MS-JP	\$1,795	\$1,842	\$1,842	\$2,082	\$2,174



SERIES 500 WIDE STILE						
HAND	DESCRIPTION	FINISH CODE / DOOR PRICE				
		#10 CLEAR	#20 BRONZE	#81 WHITE	#2604 POWDER	#2605 POWDER
RH	3696WS-AP	\$925	\$948	\$948	\$1,088	\$1,138
LH	3696WS-BP	\$925	\$948	\$948	\$1,088	\$1,138
RH	4296WS-AP	\$950	\$974	\$974	\$1,122	\$1,175
LH	4296WS-BP	\$950	\$974	\$974	\$1,122	\$1,175
PAIR	7296WS-JP	\$1,878	\$1,926	\$1,926	\$2,194	\$2,293

Note: Add "DM001" to substitute DG101 Glass Stops used for 1" Insulated Glass.

Butt Hinge CVR Panic Frame Package Includes

- 1½" or 2" x 4½" Open Back Frame
- Snap-in DS200 Door Stop w/pile
- ½" x 4" Threshold – Mill Finish

- Threshold Clips
- Prep for 1½ Pair 4½" x 4" Butt Hinges

- Prep for DH3692 CVR Panic(s)
- Frame assembly fastener package

Note: All Hardware on Powder coat products is furnished in a standard clear finish.

Note: Standard Frame Height for Transom Frames = 10'-5 ½".

Order Number Example: **3696-BP-FT2** (Size) - (Hand or Pair) - (Type)

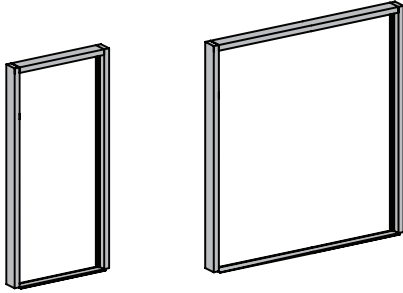

FL200 DOOR FRAME (Non-Transom)						
HAND	DESCRIPTION	FINISH CODE / FRAME PRICE				
		#10 CLEAR	#20 BRONZE	#81 WHITE	#2604 POWDER	#2605 POWDER
RH	3696-AP-F2	\$342	\$354	\$354	\$443	\$475
LH	3696-BP-F2	\$342	\$354	\$354	\$443	\$475
RH	4296-AP-F2	\$348	\$361	\$361	\$453	\$486
LH	4296-BP-F2	\$348	\$361	\$361	\$453	\$486
PAIR	7296-JP-F2	\$401	\$415	\$415	\$523	\$561

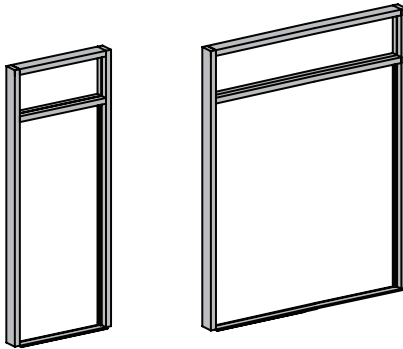

FL200 DOOR FRAME WITH TRANSOM						
HAND	DESCRIPTION	FINISH CODE / FRAME PRICE				
		#10 CLEAR	#20 BRONZE	#81 WHITE	#2604 POWDER	#2605 POWDER
RH	3696-AP-FT2	\$440	\$456	\$456	\$564	\$604
LH	3696-BP-FT2	\$440	\$456	\$456	\$564	\$604
RH	4296-AP-FT2	\$450	\$467	\$467	\$579	\$620
LH	4296-BP-FT2	\$450	\$467	\$467	\$579	\$620
PAIR	7296-JP-FT2	\$525	\$546	\$546	\$678	\$727

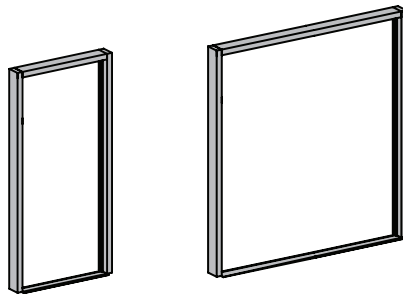

FL300 DOOR FRAME (Non-Transom)						
HAND	DESCRIPTION	FINISH CODE / FRAME PRICE				
		#10 CLEAR	#20 BRONZE	#81 WHITE	#2604 POWDER	#2605 POWDER
RH	3696-AP-F3	\$350	\$362	\$362	\$453	\$486
LH	3696-BP-F3	\$350	\$362	\$362	\$453	\$486
RH	4296-AP-F3	\$356	\$369	\$369	\$463	\$497
LH	4296-BP-F3	\$356	\$369	\$369	\$463	\$497
PAIR	7296-JP-F3	\$413	\$427	\$427	\$537	\$575

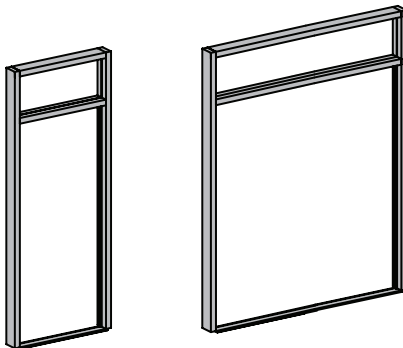

FL300 DOOR FRAME WITH TRANSOM						
HAND	DESCRIPTION	FINISH CODE / FRAME PRICE				
		#10 CLEAR	#20 BRONZE	#81 WHITE	#2604 POWDER	#2605 POWDER
RH	3696-AP-FT3	\$465	\$483	\$483	\$614	\$661
LH	3696-BP-FT3	\$465	\$483	\$483	\$614	\$661
RH	4296-AP-FT3	\$474	\$494	\$494	\$629	\$678
LH	4296-BP-FT3	\$474	\$494	\$494	\$629	\$678
PAIR	7296-JP-FT3	\$547	\$570	\$570	\$728	\$784

Entrances

Standard Doors • Butt Hinge/Offset Arm

Butt Hinge - Offset Arm Door Package Includes

- Traditional 1" rd Pull/Push Hardware
- Glass Stops for ¾" Glazing
- One Pair 4½" x 4" Butt Hinges
- Slide Channel installed with Offset Arm
- MS Hook Bolt - Single or Active Leaf
- Top & Bottom Flush Bolts Inactive Leaf
- Keyed Cylinder Exterior
- Thumb Turn Interior

Note: Reference Hardware Section of the Price Catalog for Door Closers and Loose Hardware Items not included in Standard Entrance section.

Note: All Hardware on Powder coat products is furnished in a standard clear finish.

Note: D102 Top Rail on Narrow Stile Doors with offset arm.

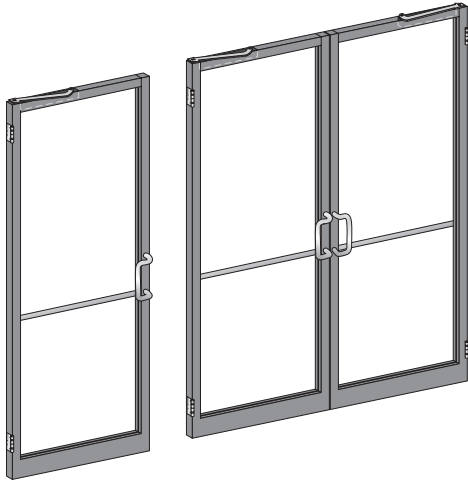

Order Number Example: **3684MS-AO** (Size and Series) - (Hand or Pair)

SERIES 213 NARROW STILE						
HAND	DESCRIPTION	FINISH CODE / DOOR PRICE				
		#10 CLEAR	#20 BRONZE	#81 WHITE	#2604 POWDER	#2605 POWDER
RH	3684-AO	\$624	\$651	\$651	\$743	\$780
LH	3684-BO	\$624	\$651	\$651	\$743	\$780
RH	4284-AO	\$656	\$678	\$678	\$781	\$820
LH	4284-BO	\$656	\$678	\$678	\$781	\$820
PAIR	7284-JO	\$1,272	\$1,328	\$1,328	\$1,489	\$1,558



SERIES 380 MEDIUM STILE						
HAND	DESCRIPTION	FINISH CODE / DOOR PRICE				
		#10 CLEAR	#20 BRONZE	#81 WHITE	#2604 POWDER	#2605 POWDER
RH	3684MS-AO	\$669	\$697	\$697	\$803	\$845
LH	3684MS-BO	\$669	\$697	\$697	\$803	\$845
RH	4284MS-AO	\$703	\$726	\$726	\$846	\$890
LH	4284MS-BO	\$703	\$726	\$726	\$846	\$890
PAIR	7284MS-JO	\$1,361	\$1,419	\$1,419	\$1,621	\$1,704

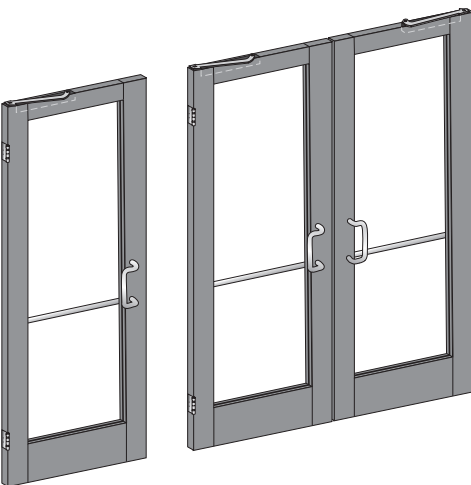

SERIES 500 WIDE STILE						
HAND	DESCRIPTION	FINISH CODE / DOOR PRICE				
		#10 CLEAR	#20 BRONZE	#81 WHITE	#2604 POWDER	#2605 POWDER
RH	3684WS-AO	\$706	\$734	\$734	\$853	\$898
LH	3684WS-BO	\$706	\$734	\$734	\$853	\$898
RH	4284WS-AO	\$740	\$764	\$764	\$895	\$943
LH	4284WS-BO	\$740	\$764	\$764	\$895	\$943
PAIR	7284WS-JO	\$1,437	\$1,495	\$1,495	\$1,720	\$1,809

Note: Add "DM001" to substitute DG101 Glass Stops used for 1" Insulated Glass.

Butt Hinge - Offset Arm Frame Package Includes

- 1½" or 2" x 4½" Open Back Frame
- Snap-in DS200 Door Stop w/pile
- ½" x 4" Threshold – Mill Finish
- Threshold Clips
- Prep for Lock Strike
- Prep for One Pair 4½" x 4" Butt Hinges
- Prep for Top & Bottom Flush Bolts (pair)
- Prep for COC
- Frame assembly fastener package
- Applied DS202 Header Door stop

Note: All Hardware on Powder coat products is furnished in a standard clear finish.

Note: Standard Frame Height for Transom Frames = 10'-5 ½".

Order Number Example: **3684-BO-FT2** (Size) - (Hand or Pair) - (Type)

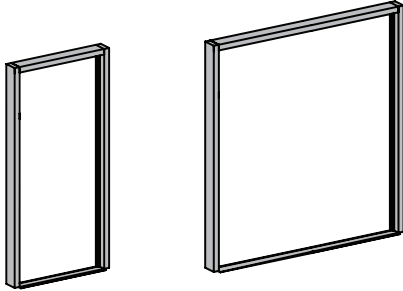

FL200 DOOR FRAME (Non-Transom)						
HAND	DESCRIPTION	FINISH CODE / FRAME PRICE				
		#10 CLEAR	#20 BRONZE	#81 WHITE	#2604 POWDER	#2605 POWDER
RH	3684-AO-F2	\$400	\$410	\$410	\$493	\$522
LH	3684-BO-F2	\$400	\$410	\$410	\$493	\$522
RH	4284-AO-F2	\$406	\$416	\$416	\$504	\$534
LH	4284-BO-F2	\$406	\$416	\$416	\$504	\$534
PAIR	7284-JO-F2	\$497	\$510	\$510	\$615	\$651

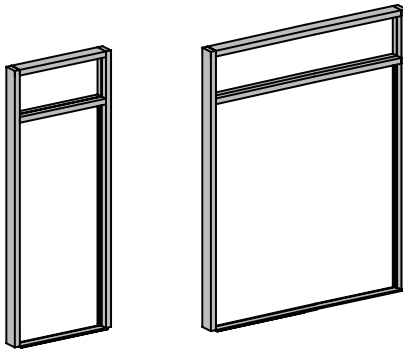

FL200 DOOR FRAME WITH TRANSOM						
HAND	DESCRIPTION	FINISH CODE / FRAME PRICE				
		#10 CLEAR	#20 BRONZE	#81 WHITE	#2604 POWDER	#2605 POWDER
RH	3684-AO-FT2	\$539	\$556	\$556	\$675	\$718
LH	3684-BO-FT2	\$539	\$556	\$556	\$675	\$718
RH	4284-AO-FT2	\$551	\$568	\$568	\$695	\$741
LH	4284-BO-FT2	\$551	\$568	\$568	\$695	\$741
PAIR	7284-JO-FT2	\$670	\$692	\$692	\$855	\$912

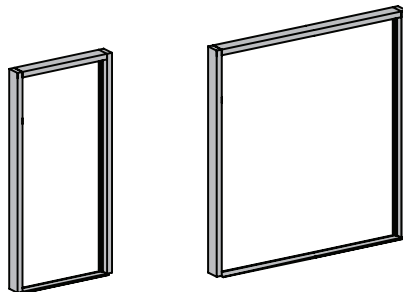

FL300 DOOR FRAME (Non-Transom)						
HAND	DESCRIPTION	FINISH CODE / FRAME PRICE				
		#10 CLEAR	#20 BRONZE	#81 WHITE	#2604 POWDER	#2605 POWDER
RH	3684-AO-F3	\$413	\$424	\$424	\$510	\$540
LH	3684-BO-F3	\$413	\$424	\$424	\$510	\$540
RH	4284-AO-F3	\$420	\$432	\$432	\$521	\$552
LH	4284-BO-F3	\$420	\$432	\$432	\$521	\$552
PAIR	7284-JO-F3	\$518	\$531	\$531	\$640	\$676

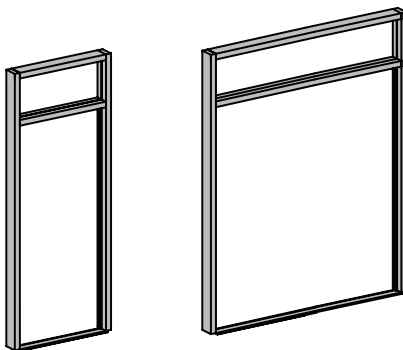

FL300 DOOR FRAME WITH TRANSOM						
HAND	DESCRIPTION	FINISH CODE / FRAME PRICE				
		#10 CLEAR	#20 BRONZE	#81 WHITE	#2604 POWDER	#2605 POWDER
RH	3684-AO-FT3	\$581	\$602	\$602	\$754	\$807
LH	3684-BO-FT3	\$581	\$602	\$602	\$754	\$807
RH	4284-AO-FT3	\$593	\$615	\$615	\$775	\$831
LH	4284-BO-FT3	\$593	\$615	\$615	\$775	\$831
PAIR	7284-JO-FT3	\$716	\$741	\$741	\$941	\$1,008

Entrances

Standard Doors • Butt Hinge/Offset Arm

Butt Hinge - Offset Arm Door Package Includes

- Traditional 1" rd Pull/Push Hardware
- Glass Stops for ¼" Glazing
- 1½ Pair 4½" x 4" Butt Hinges
- Slide Channel installed with Offset Arm
- MS Hook Bolt - Single or Active Leaf
- Top & Bottom Flush Bolts Inactive Leaf
- Keyed Cylinder Exterior
- Thumb Turn Interior

Note: Reference Hardware Section of the Price Catalog for Door Closers and Loose Hardware Items not included in Standard Entrance section.

Note: All Hardware on Powder coat products is furnished in a standard clear finish.

Note: D102 Top Rail on Narrow Stile Doors with offset arm.

Order Number Example: 3696MS-BP (Size and Series) - (Hand or Pair)



SERIES 213 NARROW STILE						
HAND	DESCRIPTION	FINISH CODE / DOOR PRICE				
		#10 CLEAR	#20 BRONZE	#81 WHITE	#2604 POWDER	#2605 POWDER
RH	3696-AO	\$668	\$697	\$697	\$800	\$841
LH	3696-BO	\$668	\$697	\$697	\$800	\$841
RH	4296-AO	\$703	\$727	\$727	\$842	\$885
LH	4296-BO	\$703	\$727	\$727	\$842	\$885
PAIR	7296-JO	\$1,364	\$1,424	\$1,424	\$1,603	\$1,680



SERIES 380 MEDIUM STILE						
HAND	DESCRIPTION	FINISH CODE / DOOR PRICE				
		#10 CLEAR	#20 BRONZE	#81 WHITE	#2604 POWDER	#2605 POWDER
RH	3696MS-AO	\$718	\$748	\$748	\$868	\$914
LH	3696MS-BO	\$718	\$748	\$748	\$868.	\$914
RH	4296MS-AO	\$755	\$780	\$780	\$913	\$962
LH	4296MS-BO	\$755	\$780	\$780	\$913	\$962
PAIR	7296MS-JO	\$1,464	\$1,525	\$1,525	\$1,752	\$1,843



SERIES 500 WIDE STILE						
HAND	DESCRIPTION	FINISH CODE / DOOR PRICE				
		#10 CLEAR	#20 BRONZE	#81 WHITE	#2604 POWDER	#2605 POWDER
RH	3696WS-AO	\$760	\$790	\$790	\$923	\$974
LH	3696WS-BO	\$760	\$790.	\$790.	\$923	\$974
RH	4296WS-AO	\$797	\$822	\$822	\$969	\$1,022
LH	4296WS-BO	\$797	\$822	\$822	\$969	\$1,022
PAIR	7296WS-JO	\$1,547	\$1,609	\$1,609	\$1,863	\$1,962

Note: Add "DM001" to substitute DG101 Glass Stops used for 1" Insulated Glass.

Butt Hinge - Offset Arm Frame Package Includes

- 1½" or 2" x 4½" Open Back Frame
- Snap-in DS200 Door Stop w/pile
- ½" x 4" Threshold – Mill Finish
- Threshold Clips
- Prep for Lock Strike
- Prep for 1½ Pair 4½" x 4" Butt Hinges
- Prep for Top & Bottom Flush Bolts (pair)
- Prep for COC
- Frame assembly fastener package
- Applied DS202 Header Door stop

Note: All Hardware on Powder coat products is furnished in a standard clear finish.

Note: Standard Frame Height for Transom Frames = 10'-5 ½".

Order Number Example: 3696-BO-FT2 (Size) - (Hand or Pair) - (Type)

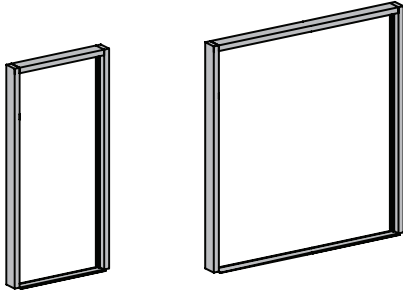

FL200 DOOR FRAME (Non-Transom)						
HAND	DESCRIPTION	FINISH CODE / FRAME PRICE				
		#10 CLEAR	#20 BRONZE	#81 WHITE	#2604 POWDER	#2605 POWDER
RH	3696-AO-F2	\$431	\$443	\$443	\$536	\$568
LH	3696-BO-F2	\$431	\$443	\$443	\$536	\$568
RH	4296-AO-F2	\$437	\$449	\$449	\$546	\$580
LH	4296-BO-F2	\$437	\$449	\$449	\$546	\$580
PAIR	7296-JO-F2	\$532	\$546	\$546	\$661	\$700

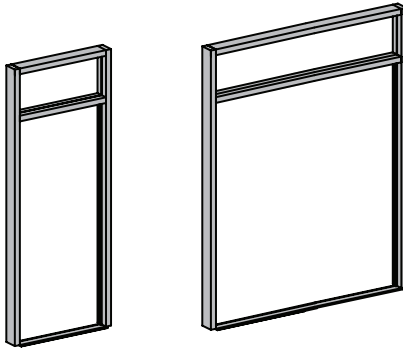

FL200 DOOR FRAME WITH TRANSOM						
HAND	DESCRIPTION	FINISH CODE / FRAME PRICE				
		#10 CLEAR	#20 BRONZE	#81 WHITE	#2604 POWDER	#2605 POWDER
RH	3696-AO-FT2	\$555	\$572	\$572	\$695	\$740
LH	3696-BO-FT2	\$555	\$572	\$572	\$695	\$740
RH	4296-AO-FT2	\$567	\$584	\$584	\$715	\$762
LH	4296-BO-FT2	\$567	\$584	\$584	\$715	\$762
PAIR	7296-JO-FT2	\$690	\$712	\$712	\$879	\$937

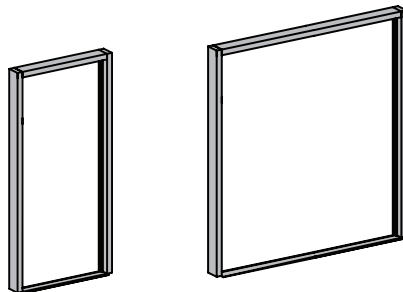

FL300 DOOR FRAME (Non-Transom)						
HAND	DESCRIPTION	FINISH CODE / FRAME PRICE				
		#10 CLEAR	#20 BRONZE	#81 WHITE	#2604 POWDER	#2605 POWDER
RH	3696-AO-F3	\$445	\$457	\$457	\$553	\$587
LH	3696-BO-F3	\$445	\$457	\$457	\$553	\$587
RH	4296-AO-F3	\$452	\$465	\$465	\$565	\$599
LH	4296-BO-F3	\$452	\$465	\$465	\$565	\$599
PAIR	7296-JO-F3	\$553	\$567	\$567	\$686	\$726

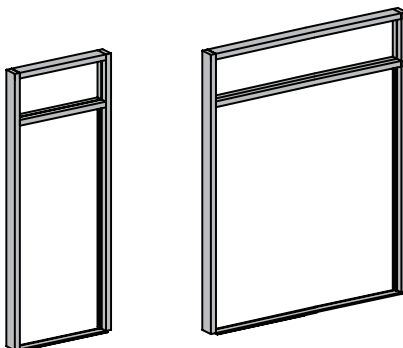

FL300 DOOR FRAME WITH TRANSOM						
HAND	DESCRIPTION	FINISH CODE / FRAME PRICE				
		#10 CLEAR	#20 BRONZE	#81 WHITE	#2604 POWDER	#2605 POWDER
RH	3696-AO-FT3	\$589	\$608	\$608	\$755	\$807
LH	3696-BO-FT3	\$589	\$608	\$608	\$755	\$807
RH	4296-AO-FT3	\$601	\$621	\$621	\$776	\$831
LH	4296-BO-FT3	\$601	\$621	\$621	\$776	\$831
PAIR	7296-JO-FT3	\$727	\$752	\$752	\$946	\$1,012

Entrances

Standard Doors • Butt Hinge/Offset Arm/Panic

Butt Hinge – CVR Panic – Offset Arm Door Package Includes

- Traditional 1" rd Pull/Push Hardware
- Slide Channel installed with Offset Arm
- Keyed Cylinder Exterior - Single or Active Leaf
- Glass Stops for ¼" Glazing
- One Pair 4½" x 4" Butt Hinges
- DH3692 CVR Touch Bar Panic(s)

Note: Reference Hardware Section of the Price Catalog for Door Closers and Loose Hardware Items not included in Standard Entrance section.

Note: All Hardware on Powder coat products is furnished in a standard clear finish.

Note: D102 Top Rail on Narrow Stile Doors with offset arm.

Order Number Example: 3684MS-AOP (Size and Series) - (Hand or Pair)



SERIES 213 NARROW STILE						
HAND	DESCRIPTION	FINISH CODE / DOOR PRICE				
		#10 CLEAR	#20 BRONZE	#81 WHITE	#2604 POWDER	#2605 POWDER
RH	3684-AOP	\$903	\$923	\$923	\$1,022	\$1,059
LH	3684-BOP	\$903	\$923	\$923	\$1,022	\$1,059
RH	4284-AOP	\$924	\$945	\$945	\$1,049	\$1,088
LH	4284-BOP	\$924	\$945	\$945	\$1,049	\$1,088
PAIR	7284-JOP	\$1,834	\$1,876	\$1,876	\$2,049	\$2,119



SERIES 380 MEDIUM STILE						
HAND	DESCRIPTION	FINISH CODE / DOOR PRICE				
		#10 CLEAR	#20 BRONZE	#81 WHITE	#2604 POWDER	#2605 POWDER
RH	3684MS-AOP	\$948	\$969	\$969	\$1,083	\$1,125
LH	3684MS-BOP	\$948	\$969	\$969	\$1,083	\$1,125
RH	4284MS-AOP	\$971	\$993	\$993	\$1,114	\$1,158
LH	4284MS-BOP	\$971	\$993	\$993	\$1,114	\$1,158
PAIR	7284MS-JOP	\$1,922	\$1,965	\$1,965	\$2,182	\$2,264



SERIES 500 WIDE STILE						
HAND	DESCRIPTION	FINISH CODE / DOOR PRICE				
		#10 CLEAR	#20 BRONZE	#81 WHITE	#2604 POWDER	#2605 POWDER
RH	3684WS-AOP	\$985	\$1,006	\$1,006	\$1,131	\$1,177
LH	3684WS-BOP	\$985	\$1,006	\$1,006	\$1,131	\$1,177
RH	4284WS-AOP	\$1,008	\$1,030	\$1,030	\$1,162	\$1,211
LH	4284WS-BOP	\$1,008	\$1,030	\$1,030	\$1,162	\$1,211
PAIR	7284WS-JOP	\$1,997	\$2,041	\$2,041	\$2,280	\$2,369

Note: Add "DM001" to substitute DG101 Glass Stops used for 1" Insulated Glass.

Butt Hinge – CVR Panic – Offset Arm Frame Package Includes

- 1¼" or 2" x 4½" Open Back Frame
- Snap-in DS200 Door Stop w/pile
- ½" x 4" Threshold – Mill Finish
- Prep for DH3692 CVR Panic(s)
- Prep for One Pair 4½" x 4" Butt Hinges
- Threshold Clips
- Prep for COC
- Frame assembly fastener package
- Applied DS202 Header Door stop

Note: All Hardware on Powder coat products is furnished in a standard clear finish.

Note: Standard Frame Height for Transom Frames = 10' - 5 ½".

Order Number Example: 3684-AOP-FT2 (Size) - (Hand or Pair) - (Type)

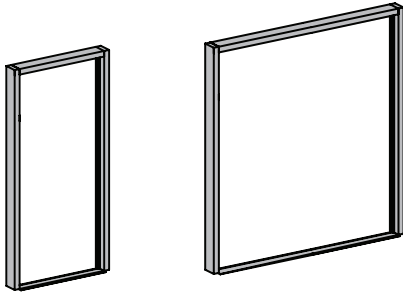

FL200 DOOR FRAME (Non-Transom)						
HAND	DESCRIPTION	FINISH CODE / FRAME PRICE				
		#10 CLEAR	#20 BRONZE	#81 WHITE	#2604 POWDER	#2605 POWDER
RH	3684-AOP-F2	\$413	\$424	\$424	\$507	\$536
LH	3684-BOP-F2	\$413	\$424	\$424	\$507	\$536
RH	4284-AOP-F2	\$420	\$430	\$430	\$517	\$547
LH	4284-BOP-F2	\$420	\$430	\$430	\$517	\$547
PAIR	7284-JOP-F2	\$511	\$523	\$523	\$629	\$664

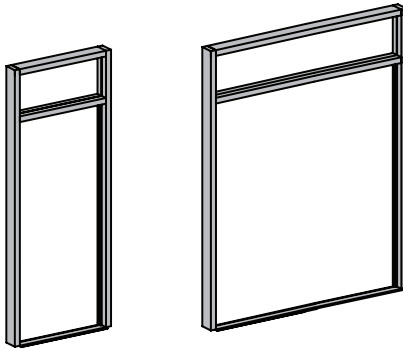

FL200 DOOR FRAME WITH TRANSOM						
HAND	DESCRIPTION	FINISH CODE / FRAME PRICE				
		#10 CLEAR	#20 BRONZE	#81 WHITE	#2604 POWDER	#2605 POWDER
RH	3684-AOP-FT2	\$553	\$569	\$569	\$688	\$732
LH	3684-BOP-FT2	\$553	\$569	\$569	\$688	\$732
RH	4284-AOP-FT2	\$564	\$582	\$582	\$708	\$754
LH	4284-BOP-FT2	\$564	\$582	\$582	\$708	\$754
PAIR	7284-JOP-FT2	\$684	\$705	\$705	\$868	\$926

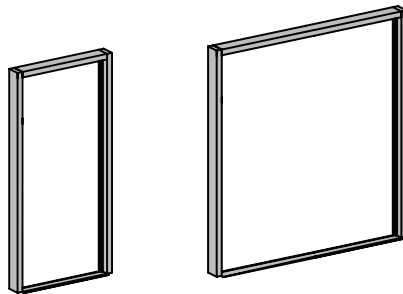

FL300 DOOR FRAME (Non-Transom)						
HAND	DESCRIPTION	FINISH CODE / FRAME PRICE				
		#10 CLEAR	#20 BRONZE	#81 WHITE	#2604 POWDER	#2605 POWDER
RH	3684-AOP-F3	\$427	\$438	\$438	\$524	\$554
LH	3684-BOP-F3	\$427	\$438	\$438	\$524	\$554
RH	4284-AOP-F3	\$434	\$445	\$445	\$535	\$566
LH	4284-BOP-F3	\$434	\$445	\$445	\$535	\$566
PAIR	7284-JOP-F3	\$532	\$544	\$544	\$653	\$690

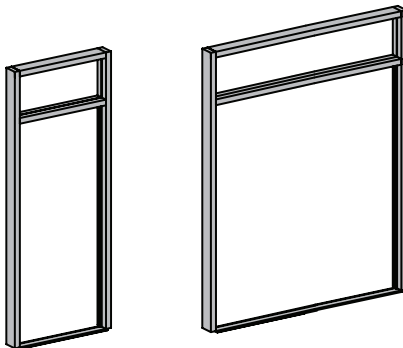

FL300 DOOR FRAME WITH TRANSOM						
HAND	DESCRIPTION	FINISH CODE / FRAME PRICE				
		#10 CLEAR	#20 BRONZE	#81 WHITE	#2604 POWDER	#2605 POWDER
RH	3684-AOP-FT3	\$596	\$616	\$616	\$768	\$821
LH	3684-BOP-FT3	\$596	\$616	\$616	\$768	\$821
RH	4284-AOP-FT3	\$607	\$628	\$628	\$788	\$844
LH	4284-BOP-FT3	\$607	\$628	\$628	\$788	\$844
PAIR	7284-JOP-FT3	\$730	\$755	\$755	\$954	\$1,022

Entrances

Standard Doors • Butt Hinge/Offset Arm/Panic

Butt Hinge – CVR Panic – Offset Arm Door Package Includes

- Traditional 1" rd Pull/Push Hardware
- Slide Channel installed with Offset Arm
- Glass Stops for ¼" Glazing
- 1½ Pair 4½" x 4" Butt Hinges
- Keyed Cylinder Exterior - Single or Active Leaf
- DH3692 CVR Touch Bar Panic(s)

Note: Reference Hardware Section of the Price Catalog for Door Closers and Loose Hardware Items not included in Standard Entrance section.

Note: All Hardware on Powder coat products is furnished in a standard clear finish.

Note: D102 Top Rail on Narrow Stile Doors with offset arm.

Order Number Example: **3696MS-AOP** (Size and Series) - (Hand or Pair)



SERIES 213 NARROW STILE						
HAND	DESCRIPTION	FINISH CODE / DOOR PRICE				
		#10 CLEAR	#20 BRONZE	#81 WHITE	#2604 POWDER	#2605 POWDER
RH	3696-AOP	\$947	\$969	\$969	\$1,079	\$1,120
LH	3696-BOP	\$947	\$969	\$969	\$1,079	\$1,120
RH	4296-AOP	\$971	\$994	\$994	\$1,109	\$1,153
LH	4296-BOP	\$971	\$994	\$994	\$1,109	\$1,153
PAIR	7296-JOP	\$1,926	\$1,972	\$1,972	\$2,164	\$2,241



SERIES 380 MEDIUM STILE						
HAND	DESCRIPTION	FINISH CODE / DOOR PRICE				
		#10 CLEAR	#20 BRONZE	#81 WHITE	#2604 POWDER	#2605 POWDER
RH	3696MS-AOP	\$997	\$1,020	\$1,020	\$1,147	\$1,193
LH	3696MS-BOP	\$997	\$1,020	\$1,020	\$1,147	\$1,193
RH	4296MS-AOP	\$1,023	\$1,047	\$1,047	\$1,181	\$1,230
LH	428496-BOP	\$1,023	\$1,047	\$1,047	\$1,181	\$1,230
PAIR	7296MS-JOP	\$2,024	\$2,071	\$2,071	\$2,312	\$2,403



SERIES 500 WIDE STILE						
HAND	DESCRIPTION	FINISH CODE / DOOR PRICE				
		#10 CLEAR	#20 BRONZE	#81 WHITE	#2604 POWDER	#2605 POWDER
RH	3696WS-AOP	\$1,039	\$1,062	\$1,062	\$1,202	\$1,253
LH	3696WS-BOP	\$1,039	\$1,062	\$1,062	\$1,202	\$1,253
RH	4296WS-AOP	\$1,065	\$1,089	\$1,089	\$1,237	\$1,290
LH	4296WS-BOP	\$1,065	\$1,089	\$1,089	\$1,237	\$1,290
PAIR	7296WS-JOP	\$2,107	\$2,155	\$2,155	\$2,423	\$2,523

Note: Add "DM001" to substitute DG101 Glass Stops used for 1" Insulated Glass.

Butt Hinge – CVR Panic – Offset Arm Frame Package Includes

- 1¼" or 2" x 4½" Open Back Frame
- Snap-in DS200 Door Stop w/pile
- ½" x 4" Threshold – Mill Finish
- Prep for DH3692 CVR Panic(s)
- Prep for 1½ Pair 4½" x 4" Butt Hinges
- Threshold Clips
- Prep for COC
- Frame assembly fastener package
- Applied DS202 Header Door stop

Note: All Hardware on Powder coat products is furnished in a standard clear finish.

Note: Standard Frame Height for Transom Frames = 10'-5 ½".

Order Number Example: 3696-AOP-FT2 (Size) - (Hand or Pair) - (Type)

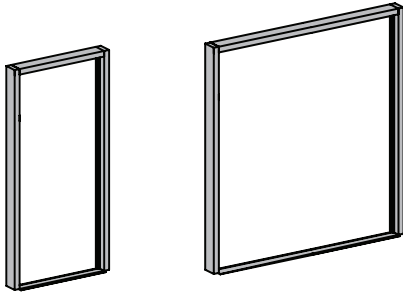

FL200 DOOR FRAME (Non-Transom)						
HAND	DESCRIPTION	FINISH CODE / FRAME PRICE				
		#10 CLEAR	#20 BRONZE	#81 WHITE	#2604 POWDER	#2605 POWDER
RH	3696-AOP-F2	\$445	\$456	\$456	\$549	\$581
LH	3696-BOP-F2	\$445	\$456	\$456	\$549	\$581
RH	4296-AOP-F2	\$451	\$463	\$463	\$560	\$593
LH	4296-BOP-F2	\$451	\$463	\$463	\$560	\$593
PAIR	7296-JOP-F2	\$546	\$559	\$559	\$675	\$713

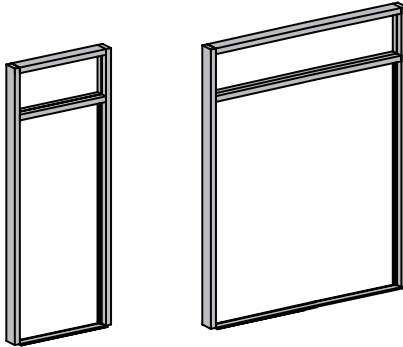

FL200 DOOR FRAME WITH TRANSOM						
HAND	DESCRIPTION	FINISH CODE / FRAME PRICE				
		#10 CLEAR	#20 BRONZE	#81 WHITE	#2604 POWDER	#2605 POWDER
RH	3696-AOP-FT2	\$569	\$586	\$586	\$709	\$753
LH	3696-BOP-FT2	\$569	\$586	\$586	\$709	\$753
RH	4296-AOP-FT2	\$580	\$598	\$598	\$728	\$775
LH	4296-BOP-FT2	\$580	\$598	\$598	\$728	\$775
PAIR	7296-JOP-FT2	\$704	\$725	\$725	\$892	\$951

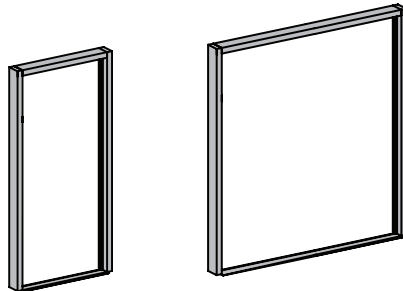

FL300 DOOR FRAME (Non-Transom)						
HAND	DESCRIPTION	FINISH CODE / FRAME PRICE				
		#10 CLEAR	#20 BRONZE	#81 WHITE	#2604 POWDER	#2605 POWDER
RH	3696-AOP-F3	\$459	\$471	\$471	\$567	\$601
LH	3696-BOP-F3	\$459	\$471	\$471	\$567	\$601
RH	4296-AOP-F3	\$466	\$478	\$478	\$578	\$613
LH	4296-BOP-F3	\$466	\$478	\$478	\$578	\$613
PAIR	7296-JOP-F3	\$567	\$581	\$581	\$700	\$740

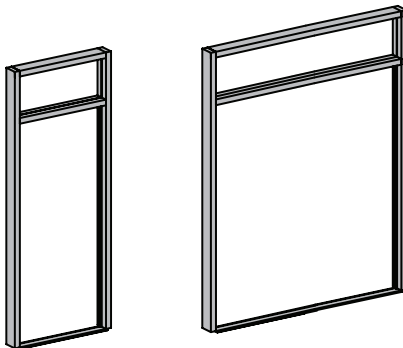

FL300 DOOR FRAME WITH TRANSOM						
HAND	DESCRIPTION	FINISH CODE / FRAME PRICE				
		#10 CLEAR	#20 BRONZE	#81 WHITE	#2604 POWDER	#2605 POWDER
RH	3696-AOP-FT3	\$602	\$622	\$622	\$769	\$821
LH	3696-BOP-FT3	\$602	\$622	\$622	\$769	\$821
RH	4296-AOP-FT3	\$614	\$635	\$635	\$790	\$845
LH	4296-BOP-FT3	\$614	\$635	\$635	\$790	\$845
PAIR	7296-JOP-FT3	\$741	\$765	\$765	\$959	\$1,025

Entrances

Standard Doors • Center Pivot

Center Pivot Door Package Includes

- Traditional 1" BTB Push Bars
- Glass Stops for 1/4" Glazing
- DH114 Center Pivot Btm Door
- DH147 Side Load Arm Package
- MS Hook Bolt - Single or Active Leaf
- Top & Bottom Flush Bolts Inactive Leaf
- Keyed Cylinder Exterior
- Thumb Turn Interior

Note: Reference Hardware Section of the Price Catalog for Door Closers and Loose Hardware Items not included in Standard Entrance section.

Note: All Hardware on Powder coat products is furnished in a standard clear finish.

Order Number Example: **3684MS-H**(Size and Series) - (Hand or Pair)



SERIES 213 NARROW STILE						
HAND	DESCRIPTION	FINISH CODE / DOOR PRICE				
		#10 CLEAR	#20 BRONZE	#81 WHITE	#2604 POWDER	#2605 POWDER
RH	3684-G	\$602	\$642	\$642	\$710	\$745
LH	3684-H	\$602	\$642	\$642	\$710	\$745
RH	4284-G	\$661	\$676	\$676	\$776	\$812
LH	4284-H	\$661	\$676	\$676	\$776	\$812
PAIR	7284-M	\$1,234	\$1,316	\$1,316	\$1,443	\$1,511



SERIES 380 MEDIUM STILE						
HAND	DESCRIPTION	FINISH CODE / DOOR PRICE				
		#10 CLEAR	#20 BRONZE	#81 WHITE	#2604 POWDER	#2605 POWDER
RH	3684MS-G	\$666	\$709	\$709	\$788	\$826
LH	3684MS-H	\$666	\$709	\$709	\$788	\$826
RH	4284MS-G	\$729	\$747	\$747	\$859	\$900
LH	4284MS-H	\$729	\$747	\$747	\$859	\$900
PAIR	7284MS-M	\$1,351	\$1,437	\$1,437	\$1,593	\$1,672



SERIES 500 WIDE STILE						
HAND	DESCRIPTION	FINISH CODE / DOOR PRICE				
		#10 CLEAR	#20 BRONZE	#81 WHITE	#2604 POWDER	#2605 POWDER
RH	3684WS-G	\$703	\$747	\$747	\$837	\$879
LH	3684WS-H	\$703	\$747	\$747	\$837	\$879
RH	4284WS-G	\$766	\$785	\$785	\$908	\$953
LH	4284WS-H	\$766	\$785	\$785	\$908	\$953
PAIR	7284WS-M	\$1,426	\$1,513	\$1,513	\$1,687	\$1,773

Note: Add "DM001" to substitute DG101 Glass Stops used for 1" Insulated Glass.

Center Pivot Frame Package Includes

- 1¼" or 2" x 4½" Open Back Frame
- ½" x 4" Threshold – Mill Finish
- DH116 Center Pivot Threshold Mounted
- Threshold Clips
- Prep for Lock Strike
- Prep for Top & Bottom Flush Bolts (pair)
- Prep for COC
- CS112 COC Cover Plate
- Frame assembly fastener package

Note: All Hardware on Powder coat products is furnished in a standard clear finish.

Note: Standard Frame Height for Transom Frames = 10'-5 ½".

Order Number Example: **3684-DO-FT2** (Size) - (Hand or Pair) - (Type)

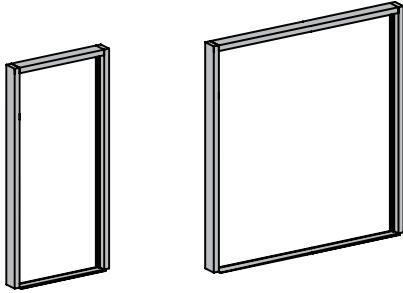

FL200 DOOR FRAME (Non-Transom)						
HAND	DESCRIPTION	FINISH CODE / FRAME PRICE				
		#10 CLEAR	#20 BRONZE	#81 WHITE	#2604 POWDER	#2605 POWDER
RH	3684-G-F2	\$428	\$435	\$435	\$493	\$513
LH	3684-H-F2	\$428	\$435	\$435	\$493	\$513
RH	4284-G-F2	\$433	\$441	\$441	\$500	\$521
LH	4284-H-F2	\$433	\$441	\$441	\$500	\$521
PAIR	7284-M-F2	\$505	\$515	\$515	\$581	\$603

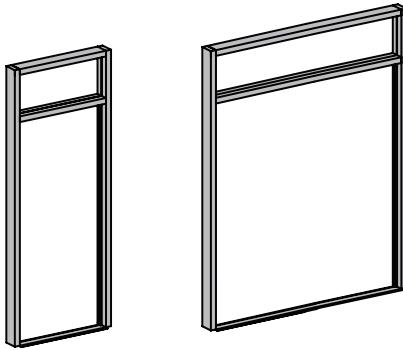

FL200 DOOR FRAME WITH TRANSOM						
HAND	DESCRIPTION	FINISH CODE / FRAME PRICE				
		#10 CLEAR	#20 BRONZE	#81 WHITE	#2604 POWDER	#2605 POWDER
RH	3684-G-FT2	\$552	\$569	\$569	\$677	\$715
LH	3684-H-FT2	\$552	\$569	\$569	\$677	\$715
RH	4284-G-FT2	\$563	\$581	\$581	\$693	\$733
LH	4284-H-FT2	\$563	\$581	\$581	\$693	\$733
PAIR	7284-M-FT2	\$670	\$693	\$693	\$822	\$869

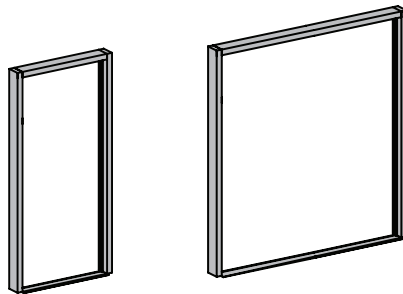

FL300 DOOR FRAME (Non-Transom)						
HAND	DESCRIPTION	FINISH CODE / FRAME PRICE				
		#10 CLEAR	#20 BRONZE	#81 WHITE	#2604 POWDER	#2605 POWDER
RH	3684-G-F3	\$429	\$437	\$437	\$498	\$518
LH	3684-H-F3	\$429	\$437	\$437	\$498	\$518
RH	4284-G-F3	\$435	\$443	\$443	\$506	\$527
LH	4284-H-F3	\$435	\$443	\$443	\$506	\$527
PAIR	7284-M-F3	\$512	\$522	\$522	\$591	\$615

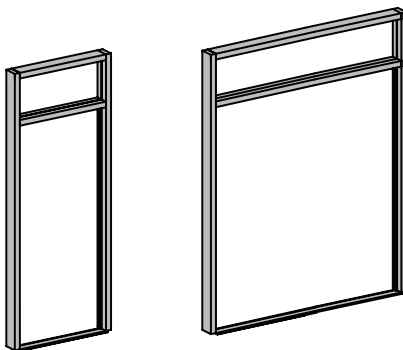

FL300 DOOR FRAME WITH TRANSOM						
HAND	DESCRIPTION	FINISH CODE / FRAME PRICE				
		#10 CLEAR	#20 BRONZE	#81 WHITE	#2604 POWDER	#2605 POWDER
RH	3684-G-FT3	\$594	\$611	\$611	\$725	\$765
LH	3684-H-FT3	\$594	\$611	\$611	\$725	\$765
RH	4284-G-FT3	\$605	\$623	\$623	\$741	\$782
LH	4284-H-FT3	\$605	\$623	\$623	\$741	\$782
PAIR	7284-M-FT3	\$709	\$732	\$732	\$869	\$918

Entrances

Standard Doors • Center Pivot

Center Pivot Door Package Includes

- Traditional 1" BTB Push Bars
- Glass Stops for 1/4" Glazing
- DH114 Center Pivot Btm Door
- DH147 Side Load Arm Package
- MS Hook Bolt - Single or Active Leaf
- Top & Bottom Flush Bolts Inactive Leaf
- Keyed Cylinder Exterior
- Thumb Turn Interior

*Note: Reference Hardware Section of the Price Catalog for Door Closers and Loose Hardware Items not included in Standard Entrance section.
Note: All Hardware on Powder coat products is furnished in a standard clear finish.*



Order Number Example: **3696MS-H**(Size and Series) - (Hand or Pair)

SERIES 213 NARROW STILE						
HAND	DESCRIPTION	FINISH CODE / DOOR PRICE				
		#10 CLEAR	#20 BRONZE	#81 WHITE	#2604 POWDER	#2605 POWDER
RH	3696-G	\$621	\$663	\$663	\$741	\$779
LH	3696-H	\$621	\$663	\$663	\$741	\$779
RH	4296-G	\$683	\$700	\$700	\$810	\$849
LH	4296-H	\$683	\$700	\$700	\$810	\$849
PAIR	7296-M	\$1,275	\$1,360	\$1,360	\$1,506	\$1,580



SERIES 380 MEDIUM STILE						
HAND	DESCRIPTION	FINISH CODE / DOOR PRICE				
		#10 CLEAR	#20 BRONZE	#81 WHITE	#2604 POWDER	#2605 POWDER
RH	3696MS-G	\$692	\$737	\$737	\$826	\$869
LH	3696MS-H	\$692	\$737	\$737	\$826	\$869
RH	4296MS-G	\$758	\$778	\$778	\$901	\$946
LH	4296MS-H	\$758	\$778	\$778	\$901	\$946
PAIR	7296MS-M	\$1,404	\$1,494	\$1,494	\$1,671	\$1,758



SERIES 500 WIDE STILE						
HAND	DESCRIPTION	FINISH CODE / DOOR PRICE				
		#10 CLEAR	#20 BRONZE	#81 WHITE	#2604 POWDER	#2605 POWDER
RH	3696WS-G	\$733	\$779	\$779	\$882	\$929
LH	3696WS-H	\$733	\$779	\$779	\$882	\$929
RH	4296WS-G	\$799	\$820	\$820	\$956	\$1,005
LH	4296WS-H	\$799	\$820	\$820	\$956	\$1,005
PAIR	7296WS-M	\$1,487	\$1,577	\$1,577	\$1,816	\$1,912

Note: Add "DM001" to substitute DG101 Glass Stops used for 1" Insulated Glass.

Center Pivot Frame Package Includes

- 1 3/4" or 2" x 4 1/2" Open Back Frame
- 1/2" x 4" Threshold – Mill Finish
- DH116 Center Pivot Threshold Mounted
- Threshold Clips
- Prep for Lock Strike
- Prep for Top & Bottom Flush Bolts (pair)
- Prep for COC
- CS112 COC Cover Plate
- Frame assembly fastener package

Note: All Hardware on Powder coat products is furnished in a standard clear finish.

Note: Standard Frame Height for Transom Frames = 10'-5 1/4".

Order Number Example: **3696-H-FT2** (Size) - (Hand or Pair) - (Type)

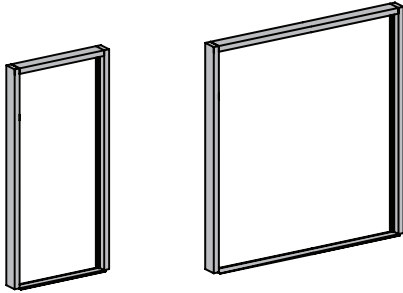

FL200 DOOR FRAME (Non-Transom)						
HAND	DESCRIPTION	FINISH CODE / FRAME PRICE				
		#10 CLEAR	#20 BRONZE	#81 WHITE	#2604 POWDER	#2605 POWDER
RH	3696-G-F2	\$441	\$450	\$450	\$515	\$537
LH	3696-H-F2	\$441	\$450	\$450	\$515	\$537
RH	4296-G-F2	\$447	\$455	\$455	\$522	\$545
LH	4296-H-F2	\$447	\$455	\$455	\$522	\$545
PAIR	7296-M-F2	\$484	\$494	\$494	\$606	\$632

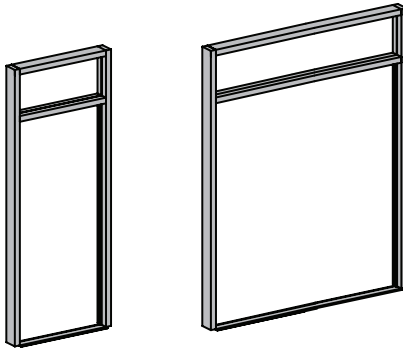

FL200 DOOR FRAME WITH TRANSOM						
HAND	DESCRIPTION	FINISH CODE / FRAME PRICE				
		#10 CLEAR	#20 BRONZE	#81 WHITE	#2604 POWDER	#2605 POWDER
RH	3696-G-FT2	\$547	\$562	\$562	\$666	\$703
LH	3696-H-FT2	\$547	\$562	\$562	\$666	\$703
RH	4296-G-FT2	\$558	\$575	\$575	\$682	\$720
LH	4296-H-FT2	\$558	\$575	\$575	\$682	\$720
PAIR	7296-M-FT2	\$630	\$651	\$651	\$808	\$854

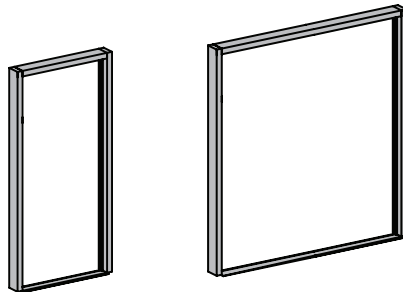

FL300 DOOR FRAME (Non-Transom)						
HAND	DESCRIPTION	FINISH CODE / FRAME PRICE				
		#10 CLEAR	#20 BRONZE	#81 WHITE	#2604 POWDER	#2605 POWDER
RH	3696-G-F3	\$444	\$452	\$452	\$520	\$543
LH	3696-H-F3	\$444	\$452	\$452	\$520	\$543
RH	4296-G-F3	\$450	\$458	\$458	\$528	\$552
LH	4296-H-F3	\$450	\$458	\$458	\$528	\$552
PAIR	7296-M-F3	\$492	\$502	\$502	\$618	\$644

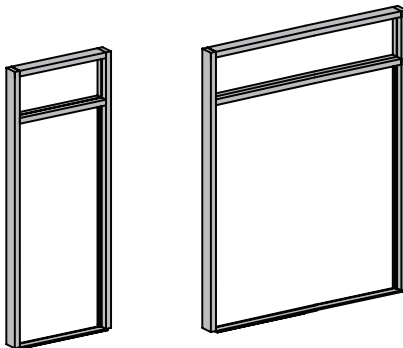

FL300 DOOR FRAME WITH TRANSOM						
HAND	DESCRIPTION	FINISH CODE / FRAME PRICE				
		#10 CLEAR	#20 BRONZE	#81 WHITE	#2604 POWDER	#2605 POWDER
RH	3696-G-FT3	\$588	\$604	\$604	\$713	\$751
LH	3696-H-FT3	\$588	\$604	\$604	\$713	\$751
RH	4296-G-FT3	\$598	\$616	\$616	\$729	\$769
LH	4296-H-FT3	\$598	\$616	\$616	\$729	\$769
PAIR	7296-M-FT3	\$668	\$689	\$689	\$855	\$902

Entrances

Showroom Doors

Continuous Geared Hinge – Door Package Includes

- Traditional 1" rd Pull/Push Hardware (Active Only)
- Glass Stops for ¼" Glazing
- Heavy Duty Continuous Hinge
- Caster Support (Inactive Leaf)
- MS Hook Bolt - Single or Active Leaf
- Top & Bottom Steel Flush Bolts Inactive Leaf
- Keyed Cylinder Exterior
- Thumb Turn Interior

*Note: Reference Hardware Section of the Price Catalog for Door Closers and Loose Hardware Items not included in Standard Entrance section.
Note: All Hardware on Powder coat products is furnished in a standard clear finish.*

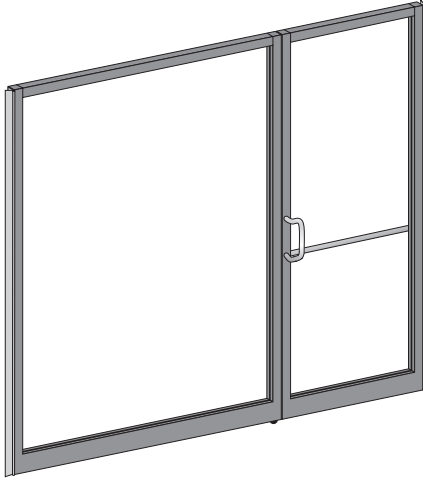

Order Number Example: **9684JS-R**(Size and Series) - (Hand or Pair)

SERIES 213 NARROW STILE DOORS						
HAND	DESCRIPTION	FINISH CODE / DOOR PRICE				
		#10 CLEAR	#20 BRONZE	#81 WHITE	#2604 POWDER	#2605 POWDER
PAIR	9684-JSL	\$1,514	\$1,645	\$1,669	\$1,773	\$1,855
PAIR	9684-JSR	\$1,514	\$1,645	\$1,669	\$1,773	\$1,855

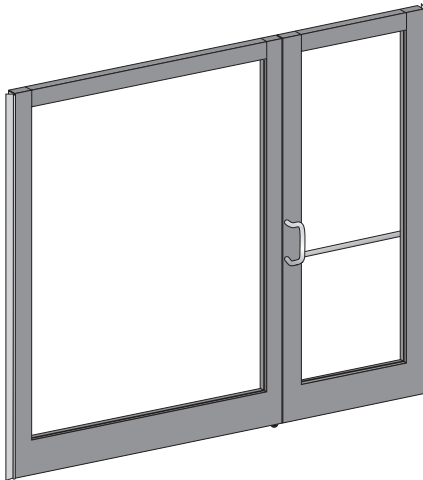

Order Number Example: **9684JS-R**(Size and Series) - (Hand or Pair)

SERIES 380 MEDIUM STILE DOORS						
HAND	DESCRIPTION	FINISH CODE / DOOR PRICE				
		#10 CLEAR	#20 BRONZE	#81 WHITE	#2604 POWDER	#2605 POWDER
PAIR	9684MS-JSL	\$1,645	\$1,779	\$1,823	\$1,969	\$2,074
PAIR	9684MS-JSR	\$1,645	\$1,779	\$1,823	\$1,969	\$2,074

Continuous Geared Hinge –Frame Package Includes

- 1½" or 2" x 4½" Open Back Frame
- Snap-in DS200 Door Stop w/pile
- ½ x 4" Threshold - Mill Finish
- Threshold clips
- Prep for Lock Strike
- Prep for Top and Bottom Flush Bolts (pair)
- Frame Assembly Fastener Package

*Note: Reference Hardware Section of the Price Catalog for Door Closers and Loose Hardware Items not included in Standard Entrance section.
 Note: All Hardware on Powder coat products is furnished in a standard clear finish.*

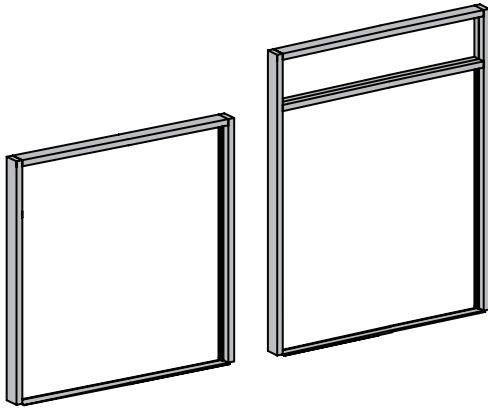

FL200 DOOR FRAMES						
HAND	DESCRIPTION	FINISH CODE / FRAME PRICE				
		#10 CLEAR	#20 BRONZE	#81 WHITE	#2604 POWDER	#2605 POWDER
PAIR	9684-JSL-F2 9684-JSR-F2	\$415	\$432	\$473	\$560	\$601
PAIR	9684-JSL-FT2 9684-JSR-FT2	\$590	\$613	\$654	\$782	\$843

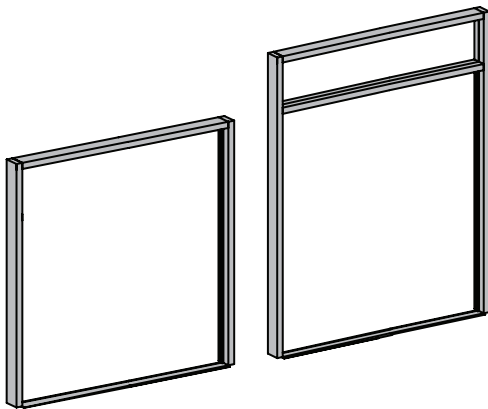

FL300 DOOR FRAMES						
HAND	DESCRIPTION	FINISH CODE / FRAME PRICE				
		#10 CLEAR	#20 BRONZE	#81 WHITE	#2604 POWDER	#2605 POWDER
PAIR	9684-JSL-F3 9684-JSR-F3	\$426	\$444	\$485	\$572	\$616
PAIR	9684-JSL-FT3 9684-JSR-FT3	\$622	\$651	\$700	\$858	\$928

Entrances

Showroom Doors

Continuous Geared Hinge – Door Package Includes

- Traditional 1" rd Pull/Push Hardware (Active Only)
- Glass Stops for ¼" Glazing
- Heavy Duty Continuous Hinge
- Caster Support (Inactive Leaf)
- MS Hook Bolt - Single or Active Leaf
- Top & Bottom Steel Flush Bolts Inactive Leaf
- Keyed Cylinder Exterior
- Thumb Turn Interior

Note: Reference Hardware Section of the Price Catalog for Door Closers and Loose Hardware Items not included in Standard Entrance section.

Note: All Hardware on Powder coat products is furnished in a standard clear finish.

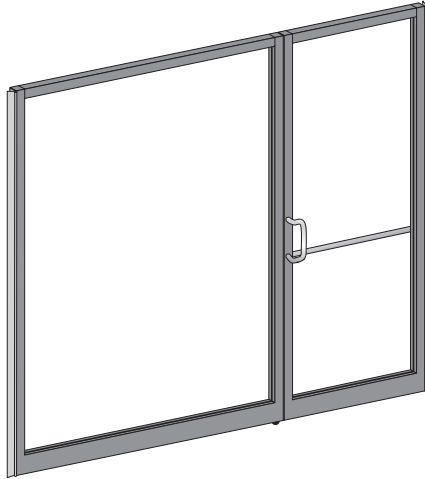

Order Number Example: **9684JS-R**(Size and Series) - (Hand or Pair)

SERIES 213 NARROW STILE DOORS						
HAND	DESCRIPTION	FINISH CODE / DOOR PRICE				
		#10 CLEAR	#20 BRONZE	#81 WHITE	#2604 POWDER	#2605 POWDER
PAIR	9696-JSL	\$1,642	\$1,808	\$1,811	\$1,928	\$2,018
PAIR	9696-JSR	\$1,642	\$1,808	\$1,811	\$1,928	\$2,018

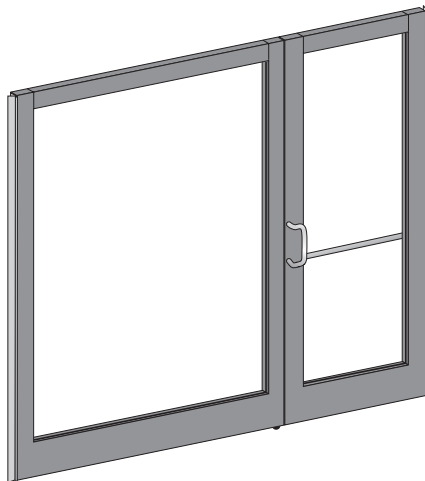

Order Number Example: **9684JS-R**(Size and Series) - (Hand or Pair)

SERIES 380 MEDIUM STILE DOORS						
HAND	DESCRIPTION	FINISH CODE / DOOR PRICE				
		#10 CLEAR	#20 BRONZE	#81 WHITE	#2604 POWDER	#2605 POWDER
PAIR	9696MS-JSL	\$1,785	\$1,954	\$1,983	\$2,141	\$2,252
PAIR	9696MS-JSR	\$1,785	\$1,954	\$1,983	\$2,141	\$2,252

Continuous Geared Hinge –Frame Package Includes

- 1½" or 2" x 4½" Open Back Frame
- Snap-in DS200 Door Stop w/pile
- ½ x 4" Threshold - Mill Finish
- Threshold clips
- Prep for Lock Strike
- Prep for Top and Bottom Flush Bolts (pair)
- Frame Assembly Fastener Package

Note: Reference Hardware Section of the Price Catalog for Door Closers and Loose Hardware Items not included in Standard Entrance section.

Note: All Hardware on Powder coat products is furnished in a standard clear finish.

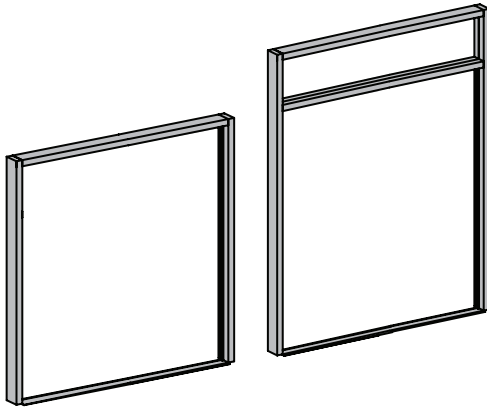

FL200 DOOR FRAMES						
HAND	DESCRIPTION	FINISH CODE / FRAME PRICE				
		#10 CLEAR	#20 BRONZE	#81 WHITE	#2604 POWDER	#2605 POWDER
PAIR	9696-JSL-F2 9696-JSR-F2	\$435	\$452	\$499	\$592	\$639
PAIR	9696-JSL-FT2 9696-JSR-FT2	\$592	\$619	\$660	\$791	\$852

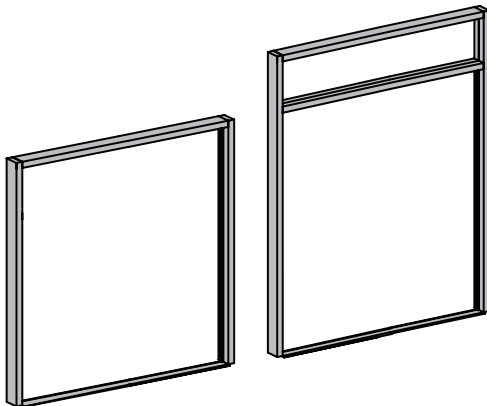

FL300 DOOR FRAMES						
HAND	DESCRIPTION	FINISH CODE / FRAME PRICE				
		#10 CLEAR	#20 BRONZE	#81 WHITE	#2604 POWDER	#2605 POWDER
PAIR	9696-JSL-F3 9696-JSR-F3	\$447	\$464	\$511	\$607	\$651
PAIR	9696-JSL-FT3 9696-JSR-FT3	\$598	\$625	\$668	\$829	\$899

Page Left Intentionally Blank

Section A2
 Table of Contents

ENTRANCES

Adds, Substitutions, and Modifications

Glass Stops 1

Push / Pulls 1

Top Rail Substitutions - Stock Door..... 2

Bottom Rail Substitutions - Stock Door 3

Horizontal Muntin Mid-Rail Adds - Standard Door 4

Hinge Modifications and Substitutions 5

Lock Substitutions6-7

Cylinder Substitutions 8



Panic / Exit Devices..... 9

Door Width and Height Add 10

Frame Width and Height Add..... 11

Page Left Intentionally Blank

GLASS STOPS									
ITEM	DESCRIPTION	LENGTH	P/N	FINISH CODE / DOOR PRICE					
				#10	#20	#81	#99	#89	
DG101 	Substitute DG101 1" Glass Stops	N/A	DM001	N/C					

PUSH / PULL									
ITEM	DESCRIPTION	LENGTH	P/N	FINISH CODE / DOOR PRICE					
				#10	#27	#81	#99	#89	
PB401 	Substitute DH41 Back to Back Push Bars	36"	DM010	\$30	\$35	Default Finish is #10 unless otherwise specified			
		42"	DM011	\$36	\$46				
		60"	DM012	\$52	\$65				
PH401 	Substitute DH42 Back to Back Pull Handles	36"	DM013	\$0	\$0				
		42"	DM014	\$0	\$0				
		60"	DM015	\$0	\$0				

Entrances

Adds, Substitutions, & Modifications

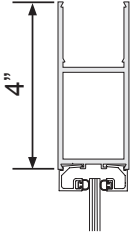
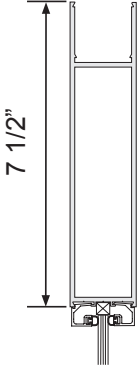
TOP RAIL								
ITEM	DESCRIPTION	LENGTH	P/N	FINISH CODE / DOOR PRICE				
				#10	#20	#81	#99	#89
	Substitute D102 for D101	36"	DM020	\$8	\$10	\$10	\$10	\$13
		42"	DM021	\$10	\$12	\$12	\$12	\$15
		60"	DM022	\$15	\$18	\$18	\$18	\$22
	Substitute D108 for D102	36"	DM023	\$10	\$13	\$13	\$13	\$18
		42"	DM024	\$12	\$15	\$15	\$15	\$20
		60"	DM025	\$18	\$22	\$22	\$22	\$29

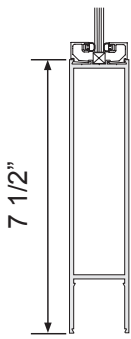
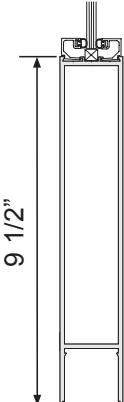
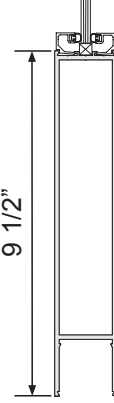
BOTTOM RAIL								
ITEM	DESCRIPTION	LENGTH	P/N	FINISH CODE / DOOR PRICE				
				#10	#20	#81	#99	#89
	Substitute D108 for D102	36"	DM032	\$10	\$13	\$13	\$13	\$18
		42"	DM033	\$12	\$15	\$15	\$15	\$20
		60"	DM034	\$18	\$22	\$22	\$22	\$29
	Substitute D109 for D102	36"	DM035	\$13	\$16	\$16	\$16	\$21
		42"	DM036	\$15	\$18	\$18	\$18	\$23
		60"	DM037	\$21	\$25	\$25	\$25	\$32
	Substitute D109 for D108	36"	DM038	\$5	\$7	\$7	\$7	\$10
		42"	DM039	\$7	\$9	\$9	\$9	\$12
		60"	DM040	\$9	\$11	\$11	\$11	\$14

Entrances

Adds, Substitutions, & Modifications

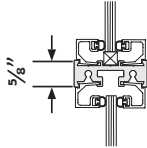
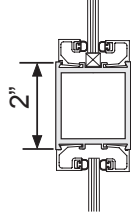
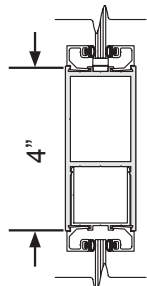
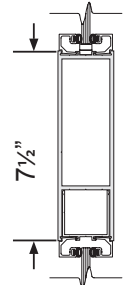
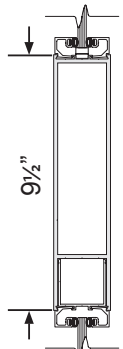
HORIZONTAL MUNTIN								
ITEM	DESCRIPTION	LENGTH	P/N	FINISH CODE / DOOR PRICE				
				#10	#20	#81	#99	#89
	Add 5/8" Horizontal Muntin	36"	DM050	\$116	\$119	\$119	\$119	\$124
		42"	DM051	\$119	\$124	\$124	\$124	\$130
		60"	DM052	\$135	\$144	\$144	\$144	\$152
	Add 2" Horizontal Muntin	36"	DM053	\$132	\$135	\$135	\$135	\$141
		42"	DM054	\$135	\$141	\$141	\$141	\$146
		60"	DM055	\$160	\$166	\$166	\$166	\$174
	Add 4" Mid-Rail	36"	DM056	\$135	\$141	\$141	\$141	\$146
		42"	DM057	\$138	\$144	\$144	\$144	\$152
		60"	DM059	\$163	\$171	\$171	\$171	\$182
	Add 7-1/2" Mid-Rail	36"	DM060	\$149	\$152	\$152	\$152	\$166
		42"	DM061	\$157	\$163	\$163	\$163	\$179
		60"	DM062	\$190	\$199	\$199	\$199	\$221
	Add 9-1/2" Mid-Rail	36"	DM063	\$157	\$163	\$163	\$163	\$182
		42"	DM064	\$168	\$174	\$174	\$174	\$196
		60"	DM065	\$207	\$215	\$215	\$215	\$246

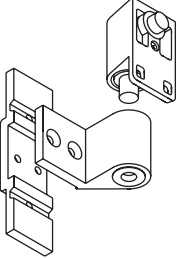
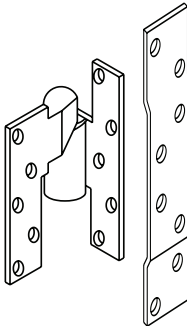
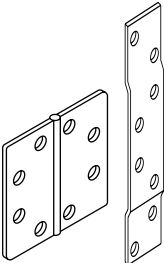
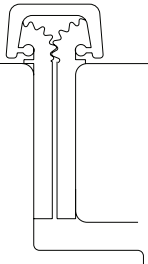
HINGE/PIVOT									
ITEM	DESCRIPTION	LENGTH	P/N	FINISH CODE / DOOR PRICE					
				#10	#20	#81	#99	#89	
DH100 	Add Standard DH100 Intermediate Pivot, Includes back-up plate and screws	N/A	DM075	\$72	\$75				
	Substitute DH107 LH or DH108 RH Intermediate Pivot, Includes back-up plates and screws	N/A	DM076	\$20	\$20				
DH107/ DH108 	Add DH107 LH or DH108 RH Intermediate Pivot, Includes back-up plates and screws	N/A	DM077	\$92	\$95				
	Substitute DH110SS Butt Hinge (Stainless Steel), Includes back-up plates and screws	N/A	DM081	\$10	\$10				
DH110SS 	Add DH110SS Butt Hinge (Stainless Steel), Includes back-up plates and screws	N/A	DM082	\$55	\$55				
	Substitute HD Continuous Gear Hinge for Butt Hinge 	84"	DM090	\$130	\$170				
96"		DM091	\$140	\$195					
108"		DM092	\$225	\$280					

Default Finish is #10 unless otherwise specified

Entrances

Adds, Substitutions, & Modifications

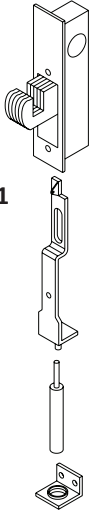
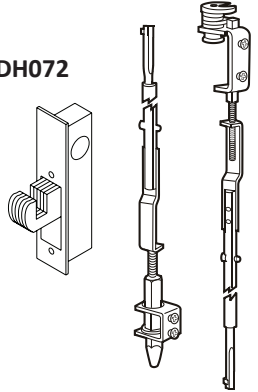
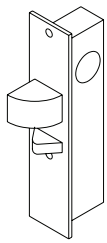
LOCKS								
ITEM	DESCRIPTION	LENGTH	P/N	FINISH CODE / DOOR PRICE				
				#10	#20	#81	#99	#89
<p>DH071</p> 	<p>Substitute DH071 2 Pt Lock, Includes faceplate</p>	N/A	DM100	\$86	\$86			
<p>DH072</p> 	<p>Substitute DH072 3 Pt Lock, Includes faceplate</p>	N/A	DM101	\$105	\$105			Default Finish is #10 unless otherwise specified
<p>DH084</p> 	<p>Substitute DH084 Deadlatch Includes faceplate</p>	N/A	DM104	\$80	\$80			

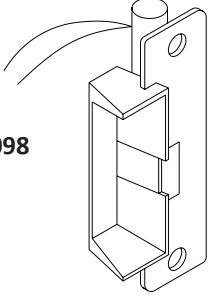
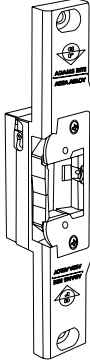
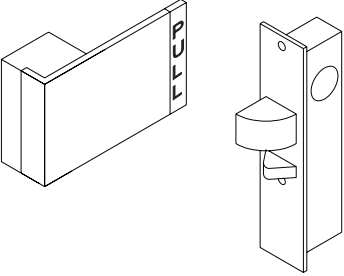
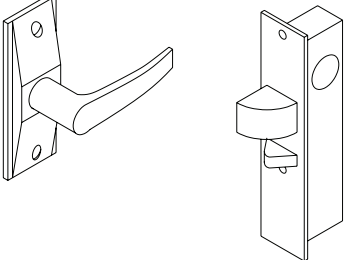

LOCKS						
ITEM	DESCRIPTION	LENGTH	P/N	FINISH CODE / DOOR PRICE		
				#10	#20	
 <p>DH098</p>	<p>Add DH098 Electric Strike</p>	N/A	DM105	\$256	\$256	Default Finish is #10 unless otherwise specified
 <p>DH099</p>	<p>Add DH099 Electric Strike for Rim Panic</p>	N/A	DM106	\$325	\$325	
 <p>DH091 DH084</p>	<p>Substitute DH084 Deadlatch with Cam and Paddle Handle</p>	N/A	DM110	\$118	\$118	
 <p>DH093 DH084</p>	<p>Substitute DH084 Deadlatch with Cam and DH093 Lever</p>	N/A	DM111	\$104	\$104	

Entrances

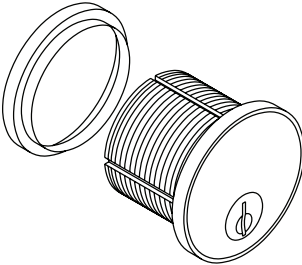
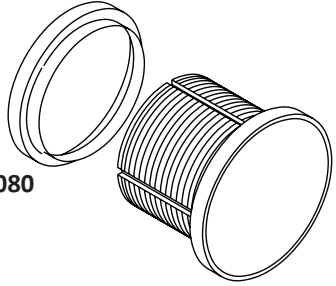
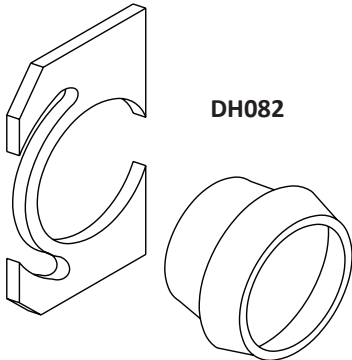
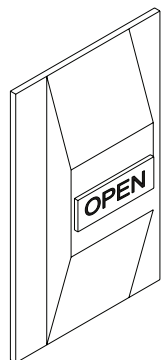
Adds, Substitutions, & Modifications

CYLINDERS								
ITEM	DESCRIPTION	LENGTH	P/N	FINISH CODE / DOOR PRICE				
				#10	#20	#81	#99	#89
 <p>DH078</p>	<p>Substitute DH078 Cylinder</p>	N/A	DM120	N/C	N/C			
 <p>DH080</p>	<p>Substitute DH080 Dummy Cylinder</p>	N/A	DM121	N/C	N/C			
 <p>DH082</p>	<p>Add DH082 Cylinder Guard</p>	N/A	DM122	\$10	\$10			
 <p>DH074</p>	<p>Add DH074 Lock Indicator</p>	N/A	DM123	\$10	\$10			

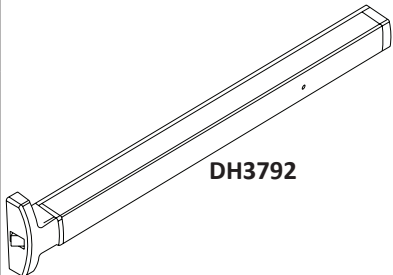
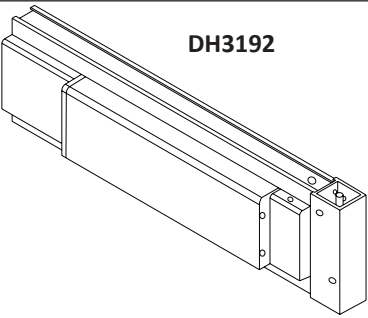
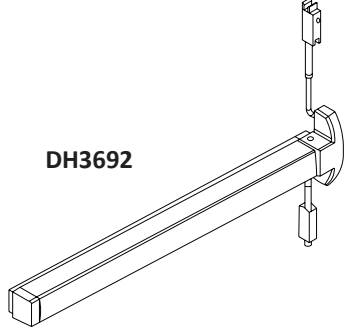
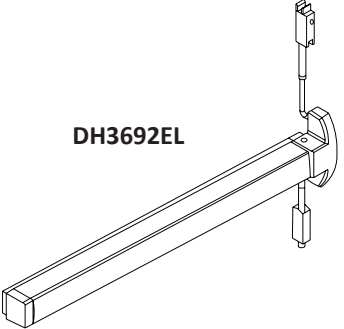
Default Finish is #10
unless otherwise
specified

PANICS / EXIT DEVICES								
ITEM	DESCRIPTION	LENGTH	P/N	FINISH CODE / DOOR PRICE				
				#10	#20	#81	#99	#89
 <p>DH3792</p>	<p>Add First Choice 3792 RIM Panic (Priced Per Leaf)</p>	36"	DM135	\$345	\$350	Default Finish is #10 unless otherwise specified		
		42"	DM136	\$355	\$360			
		48"	DM137	\$360	\$365			
 <p>DH3192</p>	<p>Add First Choice 3192 Mid Panel Panic (Priced Per Leaf)</p>	36"	DM138	\$620	\$630	\$630	\$640	\$650
		42"	DM139	\$640	\$650	\$650	\$660	\$670
		48"	DM140	\$660	\$670	\$670	\$680	\$690
 <p>DH3692</p>	<p>Add First Choice 3692 Panic (Priced Per Leaf)</p>	36"	DM141	\$380	\$385	Default Finish is #10 unless otherwise specified		
		42"	DM142	\$385	\$390			
		48"	DM143	\$390	\$395			
 <p>DH3692EL</p>	<p>Add First Choice 3692EL Panic (Priced Per Leaf)</p>	36"	DM144	\$900	\$900	Default Finish is #10 unless otherwise specified		
		42"	DM145	\$915	\$915			
		48"	DM146	\$960	\$960			
 <p>DHC-EPT</p>	<p>Add Securitron Electrical Power Transfer (Priced Per Leaf)</p>	N/A	DM180	\$185				

Entrances

Adds, Substitutions, & Modifications

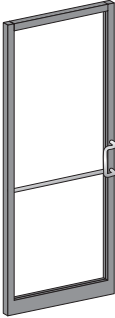
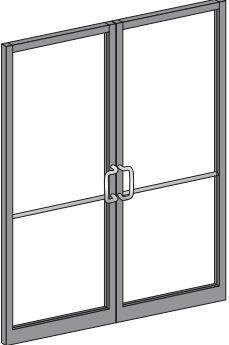
DOOR WIDTH ADD								
ITEM	DESCRIPTION	STILE	P/N	FINISH CODE / DOOR PRICE				
				#10	#20	#81	#99	#89
	ADD Single Door Width >42" up to 48"	NS	DM201	\$80	\$85	\$85	\$90	\$95
		MS	DM202	\$85	\$90	\$90	\$95	\$100
		WS	DM203	\$90	\$95	\$95	\$100	\$105
	ADD Pair Door Width >72" up to 84"	NS	DM206	\$160	\$170	\$170	\$180	\$190
		MS	DM207	\$170	\$180	\$180	\$190	\$200
		WS	DM208	\$180	\$190	\$190	\$200	\$210

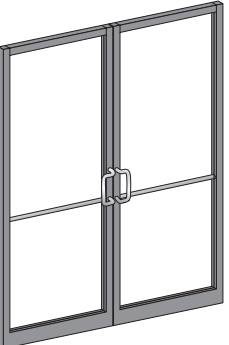
DOOR HEIGHT ADD								
ITEM	DESCRIPTION	STILE	P/N	FINISH CODE / DOOR PRICE				
				#10	#20	#81	#99	#89
	ADD Single Door Height >96" up to 108"	NS	DM210	\$45	\$50	\$50	\$60	\$65
		MS	DM211	\$50	\$55	\$55	\$65	\$70
		WS	DM212	\$55	\$60	\$60	\$70	\$75
	ADD Pair Door Height >96" up to 108"	NS	DM216	\$90	\$100	\$100	\$120	\$130
		MS	DM217	\$100	\$110	\$110	\$130	\$140
		WS	DM218	\$110	\$120	\$120	\$140	\$150

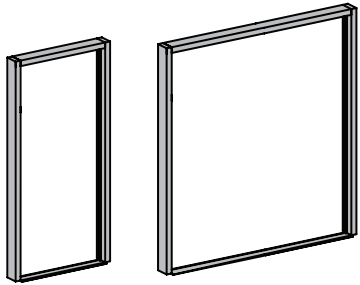
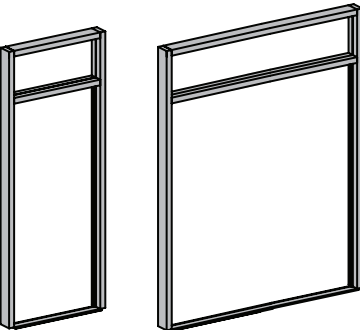
FRAME WIDTH ADD							
ITEM	DESCRIPTION	P/N	FINISH CODE / DOOR PRICE				
			#10	#20	#81	#99	#89
	Non Transom Single Door Frame Door Opening Width >42" Up To 48"	DM220	\$20	\$25	\$25	\$30	\$35
	Non Transom Pair Door Frame Door Opening Width >72" Up To 84"	DM221	\$25	\$30	\$30	\$35	\$40
	Transom Single Door Frame Door Opening Width >42" Up To 48"	DM230	\$25	\$30	\$30	\$35	\$40
	Transom Pair Door Frame Door Opening Width >72" Up To 84"	DM231	\$30	\$35	\$35	\$40	\$45

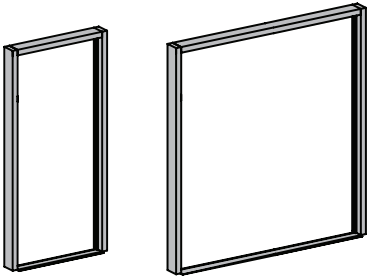
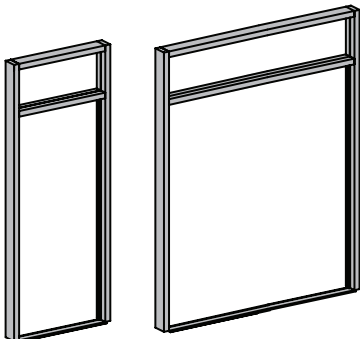
FRAME HEIGHT ADD							
ITEM	DESCRIPTION	P/N	FINISH CODE / DOOR PRICE				
			#10	#20	#81	#99	#89
	Non Transom Single Door Frame Door Opening Height >96" Up To 108"	DM240	\$18	\$20	\$20	\$25	\$30
	Non Transom Pair Door Frame Door Opening Height >96" Up To 108"	DM241	\$18	\$20	\$20	\$25	\$30
	Transom Single Door Frame Frame Height >125-1/2" Up To 144"	DM250	\$30	\$35	\$35	\$50	\$60
	Transom Pair Door Frame Frame Height >125-1/2" Up To 144"	DM251	\$30	\$35	\$35	\$50	\$60

Page Left Intentionally Blank







Section A3 Table of Contents

ENTRANCES

Standard Loose Hardware

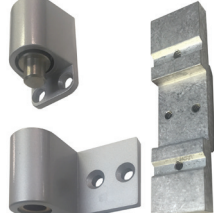
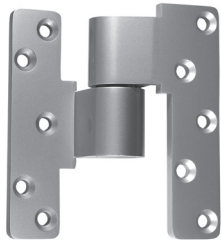

Offset Pivots / Intermediate Pivots.....	1
Butt Hinges	2
Traditional Push / Pull Hardware	3
Locks, Cylinders, and Accesories	4 -7
Surface Closers	8
Concealed Overhead Closers.....	9
Center Pivots	10
First Choice Parts.....	11
Panic Devices.....	12 - 13
Removable Mullions and Door Sweeps	14
Stock Prefabricated Thresholds.....	15

Page Left Intentionally Blank





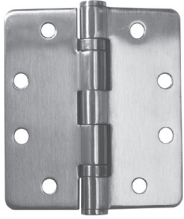



OFFSET PIVOTS / INTERMEDIATE PIVOTS							
ITEM	DESCRIPTION	P/N	FINISH CODE / DOOR PRICE				
			#10	#20	#81	#99	#89
DH101 	Top Frame Portion	DH101	\$6	\$6			
DH102 	Top Door Portion	DH102	\$6	\$6			
DH103 	Bottom Door Portion	DH103	\$9	\$9			
DH104 DH105 	Right Hand Floor Portion	DH104	\$6	\$6			
	Left Hand Floor Portion	DH105					
DH100 	Standard Intermediate Pivot. Sold as Package Only. Includes Frame Portion, Backup Plate, and Screws.	DH100	\$30	\$30			Default Finish is #10 unless otherwise specified
DH107 DH108 	Optional Left Hand Intermediate Pivot. Backup Plate and Screws Sold Separately.	DH107	\$30	\$30			
	Optional Right Hand Intermediate Pivot. Backup Plate and Screws Sold Separately.	DH108					
BP451 BP461 	Framed Backup Plate For DH107 or DH108	BP451	\$6	\$6			
	Framed Backup Plate For DH107 or DH108	BP461					
AS3-90 AS3-91 	12-24 x 1/2" PFHUCMS SS Screws for Intermediate Piv- ots, Butt Hinges and Backup Plates (100 per Pkg)	AS3-90	\$5	\$6			
		AS3-91					

Entrances

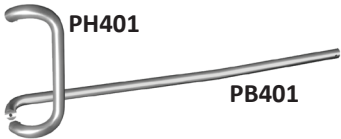
Standard Loose Hardware





BUTT HINGES							
ITEM	DESCRIPTION	P/N	FINISH CODE / DOOR PRICE				
			#10	#20	#81	#99	#89
 <p>DH110SS</p>	<p>Standard Butt Hinge (Stainless Steel) 4½" x 4" Screws and Backup Plates Sold Separately</p>	DH110SS	\$18	\$18			
 <p>BP459 BP450</p>	<p>Hinge Backup Plate For Doors (for DH109 - DH110SS)</p>	BP450	\$6	\$6			
		BP459					
	<p>Continuous Gear for 84" Door Height</p>	DH111HD-83	\$180	\$225			
	<p>Continuous Gear for 96" Door Height</p>	DH111HD-95	\$219	\$278			
	<p>Continuous Gear for 120" Door Height</p>	DH111HD -120	\$305	\$389			

Default Finish is #10
unless otherwise
specified



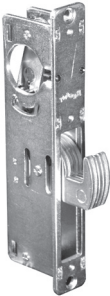

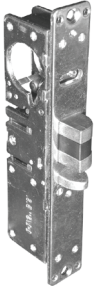

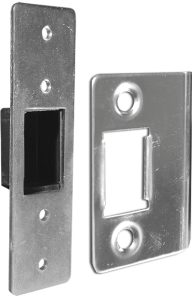
TRADITIONAL PUSH / PULL HARDWARE							
ITEM	DESCRIPTION	P/N	FINISH CODE / DOOR PRICE			#81	#89
			#10	#27	#20		
 <p>PB401</p>	1" Round Push Bar (Single) Includes DH159 Fastener Pkg	PB401-33 Doors up to 36"	\$39	\$51	\$51	Default Finish is #10 unless otherwise specified	
		PB401-39 Doors up to 42"	\$57	\$66	\$66		
		PB401-60 Doors up to 60"	\$84	\$108	\$108		
 <p>PH401</p>	1" Round x 90° Offset x 9" Ctrs Offset Pull Handle Includes DHXXX Fastener Pkg	PH401	\$24	\$27	\$33		
 <p>PH401 PB401</p>	1" Round x 90° Offset x 9" Ctrs Offset Pull Handle 1" Round Push Bar Combo Includes DH157 Fastener Pkg	DH4036 (up to 36")	\$60	\$69	\$96		
		DH4042 (up to 42")	\$69	\$75	\$105		
		DH4060 (up to 60")	\$210	\$231	\$270		
	Hardware Fastener Package	DH157	\$11	N/A	\$11		
	1" Round Push Bar (Combo) Includes DH159 Fastener Pkg	DH4136	\$114	\$120	\$180		
		DH4142	\$138	\$150	\$156		
		DH4160	\$299	\$310	\$350		
		DH159	\$11	N/A	\$11		
	1" Round x 90° Offset x 9" Ctrs Offset Pull Handle Combo Includes DH158 Fastener Pkg	DH42	\$54	\$60	\$78		
	Hardware Fastener Package	DH158	\$11	N/A	N/A		

Entrances

Standard Loose Hardware

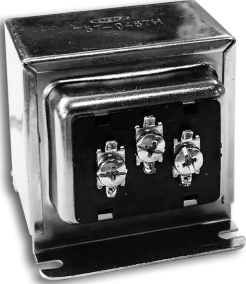
LOCKS, CYLINDERS, AND ACCESSORIES							
ITEM	DESCRIPTION	P/N	FINISH CODE / DOOR PRICE				
			#10	#20	#81	#99	#89
	Standard Hook Bolt Lock 1 1/2" Backset	DH070	\$12	N/A	Default Finish is #10 unless otherwise specified		
	Bevel Faceplate LH	DH060	\$3	\$3			
	Bevel Faceplate RH	DH061	\$3	\$3			
	Radius Faceplate	DH062	\$3	\$3			
	Standard Dead Latch (Latch Lock) 1 1/2" Backset Field Reversible Handing	DH084	\$18	N/A			
	Bevel Faceplate LH	DH065	\$3	\$3			
	Bevel Faceplate RH	DH064	\$3	\$3			
	Dead Latch Strike Includes Back Up Plate, Dust Box and Screws	DH090	\$9	N/A			

LOCKS, CYLINDERS, AND ACCESSORIES



ITEM	DESCRIPTION	P/N	FINISH CODE / DOOR PRICE				
			#10	#20	#81	#99	#89
	Electric Strike Door or Frame 1¼" x 6⅞"	DH098	\$186	\$186			
	Adams Rite 4603 Rectifier Rated 2 amps (200PIV)	DHC-4603	\$15				
	Adams Rite 4605 Transformer Converts 120VAC to 12VAC/24VAC Rated 40 volt-amp output	DHC-4605	\$57				
	MS Dead Bolt Lever Handle With Lock Indicator Includes AR Cam	DH094L LH	\$204	\$204			
		DH094R RH	\$204	\$204			
	Latch Lock Lever Handle Field Reversible Includes AR Cam	DH093	\$18	\$18			
	Latch Lock Paddle Handle Field Reversible Includes AR Cam	DH091 LH	\$36	\$36			
		DH092 RH	\$36	\$36			





Default Finish is #10 unless otherwise specified

Entrances

Standard Loose Hardware



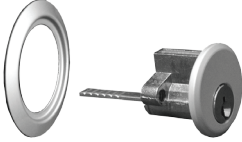

LOCKS, CYLINDERS, AND ACCESSORIES



ITEM	DESCRIPTION	P/N	FINISH CODE / DOOR PRICE					
			#10	#20	#81	#99	#89	
	Impact-Resistant 3 Point Lock 1 1/2" Cylinder Backset	DH072	\$48					N/A
	Lock Indicator (Use With Dead Bolt Only)	DH074	\$6	\$6				Default Finish is #10 unless otherwise specified
	Lever Operated Flush Bolt Standard With Nylon Tip	DH076 Up To 84"	\$9	\$9				
		DH07696 Up To 96"	\$12	\$12				
	Lever Operated Flush Bolt Impact-Resistant With Steel Tips	DH176 Up To 84"	\$15	\$15				
		DH17696 Up To 96"	\$18	\$18				

LOCKS, CYLINDERS, AND ACCESSORIES							
ITEM	DESCRIPTION	P/N	FINISH CODE / DOOR PRICE				
			#10	#20	#81	#99	#89
	1 1/2" Diameter 5 Pin Keyed Lock Cylinder	DH078	\$6	\$6			
	1 1/2" Diameter Thumb Turn	DH079	\$6	\$6			
	1 1/2" Diameter Dummy Cylinder	DH080	\$6	\$6			
	1 1/2" Diameter 5 Pin Keyed Rim Cylinder	DH081	\$9	\$9			
	Cylinder Guard With Hardened Steel Collar	DH082	\$9	\$9			

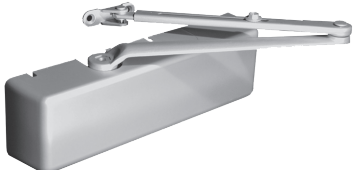
Entrances

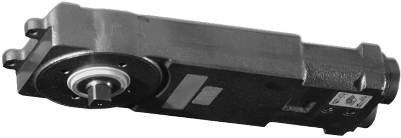
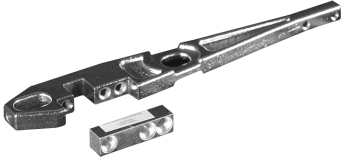
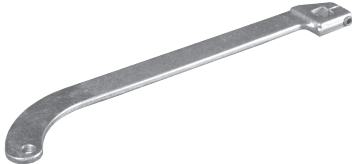
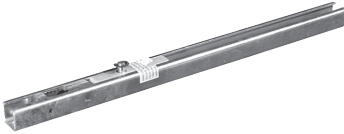

Standard Loose Hardware

SURFACE CLOSERS							
ITEM	DESCRIPTION	P/N	FINISH CODE / DOOR PRICE				
			#10	#20	#81	#99	#89
	<p>Tri-Style Surface Closer</p> <p>The Industry's most popular hole pattern, the CL026 Tri-Style Surface Closer is the most diverse 9-1/16" commercial door closer on the market today. It provides adjustments for sweep, back check, latch speed, and an adjustment spring tension of 1 to 5.</p> <ul style="list-style-type: none"> • Grade 1 ANSI A156.4 • Exceeds ADA Requirements ANSI 117.1 • Adjustable back check sweep and latch speeds • Power adjustable 1 to 5 • Tri-packed • Cover included • 9-1/16" x 3/4" hole pattern • Self-drilling screws • Includes Parallel arm bracket 	CL026	\$90	\$90			
	<p>Top Jamb Bracket</p>	CL030	\$15	\$15			
	<p>Drop Plate</p>	CL031	\$15	\$15			Default Finish is #10 unless otherwise specified
	<p>Barrier Free Adjustable Surface Closer</p> <p>The CL028 is one of the most reliable cast iron surface closers on the market today. Coral Architectural Products recommends this closer be used in medium to heavy traffic applications. The CL028 is fully adjustable and will service the heaviest doors, down to ADA compliant.</p> <ul style="list-style-type: none"> • Grade 1 ANSI A156.4 • Exceeds ADA Requirements ANSI 117.1 • Adjustable back check sweep and latch speeds • Power adjustable 1 to 6 • Tri-packed • Cover included • Self-drilling screws • Includes Parallel arm bracket 	CL028	\$210	\$210			
	<p>Drop Plate</p>	CL033	\$36	\$36			

CONCEALED OVERHEAD CLOSERS							
ITEM	DESCRIPTION	P/N	FINISH CODE / DOOR PRICE				
			#10	#20	#81	#99	#89
	Concealed Overhead Closer <ul style="list-style-type: none"> • Dual Valves to Control Closing and Latching • Fits 1-3/4" x 4-1/2" 2" x 4-1/2" and 2-1/2" x 5" Headers • Closer Body Only 	CL190 90° Hold Open	\$165	N/A			
		CL105 105° Hold Open					
		CL290 90° No Hold Open					
		CL205 105° No Hold Open					
	Side Load Top Arm Assembly	DH147	\$36	N/A	Default Finish is #10 unless otherwise specified		
	Offset Arm Assembly Requires D102 (4") Top Rail on Narrow Stile 213 & 281 Doors	DH152	\$24	N/A			
	Slide Channel For Use With Offset Arm	DH153	\$24	N/A			
	Square Corner Cover Plate For Center Pivot	CS112-1	\$21	\$24			
	Rounded Corners Cover Plate For Offset Arm Applications	DH117	\$39	\$36			

Entrances

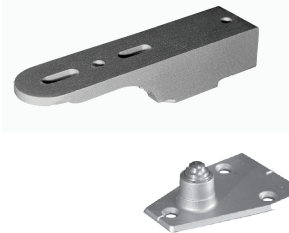

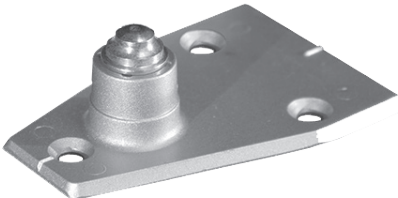

Standard Loose Hardware



CENTER PIVOTS							
ITEM	DESCRIPTION	P/N	FINISH CODE / DOOR PRICE				
			#10	#20	#81	#99	#89
	Floor Mount Bottom Center Pivot Assembly	DH145	\$63	N/A	Default Finish is #10 unless otherwise specified		
	Bottom Door Portion Center Pivot	DH114	\$33	N/A			
	Bottom Threshold Portion Center Pivot	DH116	\$30	N/A			

FIRST CHOICE PARTS							
ITEM	DESCRIPTION	P/N	FINISH CODE / DOOR PRICE				
			#10	#20	#81	#99	#89
	First Choice CVR SS Pinion Gear Stainless Steel	DHC-16001007-SS	\$25	N/A			
	First Choice Panic Dogging Key	DHC-819	\$6	N/A			
	First Choice Connecting Cable for EL Device x 36"	DHC-EL3000-3CAB	\$30	N/A			Default Finish is #10 unless otherwise specified
	First Choice Connecting Cable for EL Device x 36"	DHC-EL3000-3SP	\$36	N/A			
	First Choice 3692 CVR SS Top Strike Kit Stainless Steel	DHC-9038	\$30	N/A			

Entrances

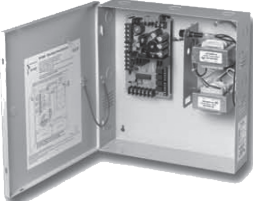

Standard Loose Hardware

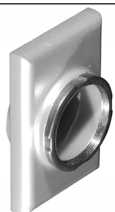
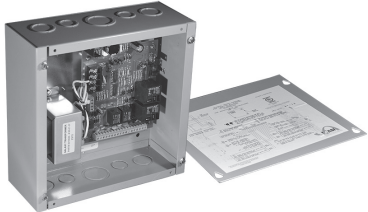
PANIC DEVICES							
ITEM	DESCRIPTION	P/N	FINISH CODE / DOOR PRICE				
			#10	#20	#81	#99	#89
	First Choice - Standard Concealed Vertical Rod Exit Device Hand Reversible	DH369236 Up To 3'-0" x 7'-0"	\$249	\$255	Default Finish is #10 unless otherwise specified		
		DH369242 Up To 3'-6" x 7'-0"	\$252	\$258			
		DH369248 Up To 4'-0" x 7'-0"	\$255	\$261			
	First Choice - Standard Concealed Vertical Rod Exit Device Hand Reversible Electric Latch Retraction	DH369236EL Up To 3'-0" x 7'-0"	\$778	\$778			
		DH369242EL Up To 3'-6" x 7'-0"	\$793	\$793			
		DH369248EL Up To 4'-0" x 7'-0"	\$837	\$837			
	First Choice - Standard RIM Exit Device Non-Handed	DH379236 Up To 3'-0"	\$243	\$249			
		DH379242 Up To 3'-6"	\$246	\$252			
		DH379248 Up To 4'-0"	\$255	\$261			
	Electric Strike For Rim Panic	DH099	\$264	\$264			
	Securitron Electrical Power Transfer (Priced Per Leaf)	DHC-EPT	\$83	\$83			

PANIC DEVICES								
ITEM	DESCRIPTION	P/N	FINISH CODE / DOOR PRICE					
			#10	#20	#81	#99	#89	
	First Choice PSEL1500 Power Supply (Single)	DHC-PSEL1500	\$733					
	First Choice PSEL3000 Power Supply (Pair)	DHC-PSEL3000	\$1286					
	Jackson Concealed Vertical Rod Exit Device Handed Up To 3'-0" x 7'-0"	DH2086L	\$837	\$867	Default Finish is #10 unless otherwise specified			
		DH2086R						
	Jackson Concealed Vertical Rod Exit Device Handed Up To 4'-0" x 7'-0"	DH2086L-48	\$867	\$882				
		DH2086R-48						
	Jackson 2086 Concealed Vertical Rod Exit Device Handed Electric Latch Retraction Up To 4'-0" x 7'-0"	DH2086ELL-48	\$1644	\$1719				
	Jackson 2086 Concealed Vertical Rod Exit Device Handed Electric Latch Retraction Up To 4'-0" x 7'-0"	DH2086ELR-48	\$1644	\$1719				
	Jackson 2086 Cylinder Mounting Pad	DH073	\$27	\$27				
	Jackson 30-2616 Power Supply	DHC-30-2616	\$867	\$				

Entrances

Standard Loose Hardware

REMOVABLE MULLIONS AND DOOR SWEEPS							
ITEM	DESCRIPTION	P/N	FINISH CODE / DOOR PRICE				
			#10	#20	#81	#99	#89
	First Choice Removable Mullion For Pair of Doors with Rim Exit Devices	DHRM370-7 Up To 7'	\$598	\$613	Default Finish is #10 unless otherwise specified		
		DHRM370-8 Up To 8'	\$607	\$622			
		DHRM370-9 Up To 9'	\$628	\$646			
	Surface Applied Bottom Rail Door Sweep Includes Screws	WS136 Up To 3'	\$9	\$9			
		WS148 Up To 4'	\$12	\$12			

STOCK PREFABRICATED THRESHOLDS

ITEM	DESCRIPTION	LENGTH	HAND	P/N	MILL
 <p>4" x 1/2" Mill Finish Threshold</p>	Standard Butt Hinge Threshold	36"	N/A	TH4-36-AB	\$30
		42"	N/A	TH4-42-AB	\$32
		48"	N/A	TH4-48-AB	\$35
		72"	N/A	TH4-72-J	\$45
		84"	N/A	TH4-84-J	\$50
	Standard Butt Hinge Threshold Panic	36"	RH	TH4-36-AP	\$35
		36"	LH	TH4-36-BP	\$35
		42"	RH	TH4-42-AP	\$38
		42"	LH	TH4-42-BP	\$38
		48"	RH	TH4-48-AP	\$42
		48"	LH	TH4-48-BP	\$42
		72"	N/A	TH4-72-JP	\$50
		84"	N/A	TH4-84-JP	\$55
	Standard Offset Pivot Threshold	36"	RH	TH4-36-C	\$30
		36"	LH	TH4-36-D	\$30
		42"	RH	TH4-42-C	\$32
		42"	LH	TH4-42-D	\$32
		48"	RH	TH4-48-C	\$35
		48"	LH	TH4-48-D	\$35
		72"	N/A	TH4-72-K	\$45
		84"	N/A	TH4-84-K	\$50
	Standard Offset Pivot Threshold Panic	36"	RH	TH4-36-CP	\$35
		36"	LH	TH4-36-DP	\$35
		42"	RH	TH4-42-CP	\$38
		42"	LH	TH4-42-DP	\$38
		48"	RH	TH4-48-CP	\$42
		48"	LH	TH4-48-DP	\$42
		72"	RH	TH4-72-KP	\$50
72"		LH	TH4-84-KP	\$55	
Standard Center Pivot Threshold	36"	N/A	TH4-36-GH	\$40	
	42"	N/A	TH4-42-GH	\$45	
	48"	N/A	TH4-48-GH	\$50	
	72"	N/A	TH4-72-M	\$60	
	84"	N/A	TH4-84-M	\$65	

Page Left Intentionally Blank

Section B
STOREFRONT SYSTEMS
Table of Contents

FL200 Storefront System.....	B1
FL300 Storefront System.....	B2
FL300T Thermal Storefront System.....	B3
FS400T Thermal Storefront System.....	B4
Angles, Channels, Flat Bars, & Tubes.....	B5
FL100 Removable Office Partitions.....	B6
FL600 Storefront System.....	B7
FS600T Thermal Storefront System.....	B8
FS600UT Thermal Storefront System.....	B9

Page Left Intentionally Blank

Section B1 Table of Contents









FL200

STOREFRONT SYSTEM

1³/₄" X 4¹/₂"

	<i>Page</i>
Standard Framing Extrusions.....	1
Optional Framing Extrusions	2-3
Door Framing Extrusions	4
Optional Door Extrusions	5
Accessories.....	6
Steel Reinforcing.....	7
Glazing Infill Charts and Setting Block/Setting Chair Charts	7





Page Left Intentionally Blank

STANDARD FRAMING EXTRUSIONS									
PART DESCRIPTION	PART NO.	PART LENGTH	PCS. PER BOX	FINISH CODE/STOCK LENGTH LIST PRICE					
				#10 CLEAR	#20 BRONZE	#81 WHITE	#2604 POWDER	#2605 POWDER	
 Head/Wall Jamb (Deep Pocket)	FL201	24'	3	\$189	\$206	\$206	\$230	\$255	
 Sill/Optional Head (Deep Pocket)	FL202	24'	4	\$164	\$178	\$178	\$184	\$201	
 Glass Stop	FL203	24'	10	\$46	\$51	\$51	\$88	\$104	
 Shallow Pocket Filler	FL205	24'	10	\$67	\$74	\$74	\$104	\$119	
 Intermediate Horizontal	FL206	24'	3	\$180	\$190	\$190	\$252	\$279	
 Standard Vertical Mullion	FL204	24'	4	\$138	\$151	\$151	\$200	\$227	
 Expansion Male Mullion (Requires VG10 Gasket Mates w/FL211 Expansion Mullion)\	FL210	24'	4	\$130	\$141	\$141	\$184	\$207	
 Expansion Female Mullion (Mates w/FL210 Expansion Mullion)	FL211	24'	4	\$134	\$145	\$145	\$170	\$189	
 Sub-Sill Flashing	FL219	24'	10	\$95	\$103	\$103	\$143	\$162	





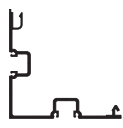
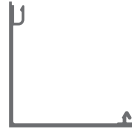
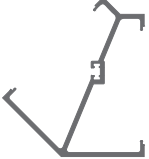

Note: Add Finish Code to the Part Number when ordering (Ex: **FL201-10** for Clear Anodized Finish)

FL200·1³/₄"x4¹/₂"

Non-Thermal Screw-Spline Storefront

OPTIONAL FRAMING EXTRUSIONS									
PART DESCRIPTION	PART NO.	PART LENGTH	PCS. PER BOX	FINISH CODE/STOCK LENGTH LIST PRICE					
				#10 CLEAR	#20 BRONZE	#81 WHITE	#2604 POWDER	#2605 POWDER	
 Deep Pocket Filler (Required w/CS135)	FL213	24'	10	\$73	\$80	\$80	\$107	\$123	
 Head/Vertical Mullion	FL214	24'	4	\$158	\$172	\$172	\$215	\$242	
 Heavy Vertical Mullion	FL216	24'	3	\$193	\$205	\$205	\$256	\$283	
 Single Pocket Corner Post Mullion	FL251	24'	4	\$194	\$208	\$208	\$251	\$279	
 Double Pocket Corner Post Mullion	FL252	24'	4	\$221	\$238	\$238	\$260	\$285	
 90° Corner Post Trim	FL350	24'	4	\$166	\$179	\$179	\$242	\$272	
 135° Corner Post Mullion (Mates w/FL213 Filler)	CS135	24'	2	\$267	\$283	\$283	\$322	\$350	



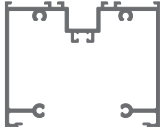





Note: Add Finish Code to the Part Number when ordering (Ex: **FL201-10** for Clear Anodized Finish)

OPTIONAL FRAMING EXTRUSIONS									
PART DESCRIPTION	PART NO.	PART LENGTH	PCS. PER BOX	FINISH CODE/STOCK LENGTH LIST PRICE					
				#10 CLEAR	#20 BRONZE	#81 WHITE	#2604 POWDER	#2605 POWDER	
 <p>1/2" Reveal Adapter (Snap fits with Open Back Wall Jambs/Head Members)</p>	CS102	24'	10	\$89	\$97	\$97	\$118	\$133	
 <p>Flat Filler Snap fits with Open Back Wall Jambs/Head Members)</p>	CS104	24'	10	\$66	\$72	\$72	\$107	\$123	
 <p>1/4" Snap-In Glazing Pocket Filler</p>	CS105	21'-5"	12	\$18	\$23	\$23	\$64	\$78	
 <p>Interlocking Stop (Snap fits with CS119 Head Expander - Requires VG10 Gasket)</p>	CS118	24'	10	\$39	\$43	\$43	\$85	\$100	
 <p>Head Expander (Snap fits with CS118 Head Expander - Requires VG10 Gasket)</p>	CS119	24'	6	\$110	\$120	\$120	\$136	\$152	
 <p>Head/Wall Jamb Anchor Clip</p>	CS300	24'	2	Mill-00 \$77	N/A	\$000	\$000	\$000	
 <p>Bulk Head Base (4 1/2" x 4 1/2" for 1/4" Glazing Requires Two FL203 Glass Stops)</p>	CS453	24'	2	\$312	\$335	\$335	\$339	\$366	







Note: Add Finish Code to the Part Number when ordering (Ex: **FL201-10** for Clear Anodized Finish)

FL200·1³/₄"x4¹/₂"

Non-Thermal Screw-Spline Storefront

DOOR FRAME EXTRUSIONS									
PART DESCRIPTION	PART NO.	PART LENGTH	PCS. PER BOX	FINISH CODE/STOCK LENGTH LIST PRICE					
				#10 CLEAR	#20 BRONZE	#81 WHITE	#2604 POWDER	#2605 POWDER	
 Door Header for Offset Doors (Requires DS200 Door Stop)	FL207	24'-6"	3	\$227	\$238	\$238	\$328	\$363	
 Door Header for Center Hung Doors (Requires CS112 Cover)	FL208	24'	4	\$159	\$169	\$169	\$235	\$263	
 Open Back Door Jamb for Offset Doors (Requires DS200 Door Stop)	FL209	24'	4	\$153	\$166	\$166	215	\$242	
 Tubular Door Header for COC Offset Doors (Requires DS202 Door Stop)	FL212	24'	4	\$177	\$184	\$184	\$309	\$349	
 Open Back Door Jamb Center Hung Doors	FL217	24'	3	\$128	\$138	\$138	\$209	\$239	
 Snap-In Cover for Center Hung Door Header (Mates with FL208 Door Header)	CS112	21'-2"	20	\$70	\$75	\$75	\$112	\$128	
 Snap-In Door Stop for 1/4" Glass (Requires WP200 Weathering)	DS200	16'	20	\$31	\$34	\$34	\$72	\$86	
 Transom Sash Base for 1/4" Glass (Requires FL518 Glass Stop)	CS113	24'	12	\$45	\$50	\$50	\$87	\$103	
 Glass Stop for Transom Sash (Mates with CS113 and CS115 Transom Sash Base)	FL518	24'	12	\$35	\$38	\$38	\$82	\$98	











Note: Add Finish Code to the Part Number when ordering (Ex: FL201-10 for Clear Anodized Finish)







OPTIONAL DOOR EXTRUSIONS									
PART DESCRIPTION		PART NO.	PART LENGTH	PCS. PER BOX	FINISH CODE/STOCK LENGTH LIST PRICE				
					#10 CLEAR	#20 BRONZE	#81 WHITE	#2604 POWDER	#2605 POWDER
	Door Rail Shoe Base	DB124	24'	8	Mill-00	N/A	N/A	N/A	N/A
					\$27				
	1/16" Door Rail Base Extension	DB123	24'	8	\$68	\$73	\$73	\$111	\$126
	Mid Rail Adapter <small>(Use with D102, 108, or 109)</small>	D113	24'	10	Mill-00	N/A	N/A	N/A	N/A
					\$35				
	4" Muntin or Sidelite Base	D102	16'-0"	4	\$139	\$146	\$146	\$190	\$209
	7 1/2" Muntin or Sidelite Base	D108	16'-0"	4	\$223	\$233	\$233	\$316	\$347
	9 1/2" Muntin or Sidelite Base	D109	16'-0"	4	\$271	\$282	\$282	\$387	\$426
	Door Glass Stop for 1/4" Glazing <small>(Use NG4 Gasket)</small>	DG100	16'-0"	20	\$23	\$29	\$29	\$75	\$90
	Door Glass Stop for 1" Glazing <small>(Use NG415 Gasket)</small>	DG101	16'-0"	18	\$20	\$27	\$27	\$72	\$88

Note: Add Finish Code to the Part Number when ordering (Ex: FL201-10 for Clear Anodized Finish)

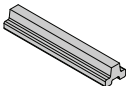
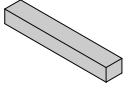
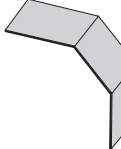
FL200·1³/₄" x 4¹/₂"

Non-Thermal Screw-Spline Storefront

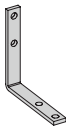
ACCESSORIES			
PART DESCRIPTION	PART NO.	QTY	PRICE PER BOX
 Spline Screw #14 x 1 HHSTS (Assembly Screw)	AS16	100 (AS16-1)	\$12
 #6 x 3/8" PPH Type AB (Attaches End Dams)	AS21	100 (AS21-1)	\$5
 #10-24 x 3/8" UCPFH (Attaching SR101 or SR102 Steel)	AS24	100 (AS24-1)	\$19
 Setting Chair (Two Per Lite Required at Sill Member)	CS100-1	50 (CS100-2)	\$58
 Drill Jig for Screw Spline (Required for Series FL200 Storefront)	DJ200	1	\$168
 End Dam for Sill Flashing (Requires Two AS21 Screws)	ED219-1	20 (ED219-2)	\$30
 EPDM Gasket (Standard Gasket for 1/2" Glazing)	NG1	300 FT. (Per Roll)	\$136
 Heavy Glazing Gasket	NG2	500 FT. (Per Roll)	\$342
 3/8" Glazing Gasket	NG3	250 FT. (Per Roll)	\$132
 D-shaped gasket	NG41S	250 FT. (Per Roll)	\$113

ACCESSORIES			
PART DESCRIPTION	PART NO.	QTY	PRICE PER BOX
 4" Long EPDM Setting Block for 1/2" Glass (Exterior Glazing - Two Per Lite)	SB2	100 (SB2-1)	\$58
 4" Long EPDM Setting Block for Int. Glazing (Horizontal - Two Per Lite)	SB5	100 (SB5-1)	\$68
 Water Diverter (Horizontal - Two Per Lite)	WD200-1	50 (WD200-2)	\$62
 Vinyl Gasket (Standard Weathering Gasket for FL210 and CS118 / CS119)	VG10	250 FT. (VG10-1) (Per Roll)	\$184
 Joint Sealant Tape (1/2" x 1/2" for Sealing Horizontal to Vertical Member Connections)	SM5601	30 FT. (Per Roll)	\$37
 Weathering for D200	WP200	500 FT. (Per Roll)	\$97
 Steel Bracket for Muntin Assembly to Door Stile	TH401	50 (TH401-2)	\$93
 #8 x 3/4" POH TEK Screw	AS7	100 (AS7-1)	\$23

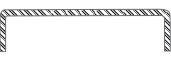
STEEL REINFORCING			
PART DESCRIPTION	PART NO.	QUANTITY LENGTH	PRICE
 1¹/₄" x 4³/₁₆" x 10 Ga. Steel Reinforcing (For Standard Vertical Mullions)	SR101	1	\$222
		10'-0"	
 1¹/₄" x 4³/₁₆" x 10 Ga. Steel Reinforcing (For Standard Vertical Mullions)	SR102	1	\$129
		10'-0"	

GLAZING INFILL CHART					
SYSTEM	GLAZING ADAPTER	REGLET WIDTH	INFILL THICKNESS	GASKET COMBINATIONS	
FL200	N/A	5/8"	3/16"	NG2	NG1
			1/4"	NG1	NG1
			5/16"	NG1	NG3
			3/8"	NG3	NG3

SETTING BLOCK AND SETTING CHAIR CHART					
GLASS SIZE	PART DESCRIPTION	PART NO.	GLAZING APPLICATION	SETTING BLOCK PART NO.	SETTING CHAIR PART NO.
1/4"	Sill Member	FL202	Exterior Glazed	SB2	CS100-1
		FL203	Interior Glazed	SB2	CS100-2
1/4"	Intermediate Horizontal	FL206	Exterior Glazed	SB2	Not Required
		FL206	Interior Glazed	SB5	Not Required
1/4"	Bulk Head Base	CS453	Exterior Glazed	SB2	CS100-1
		CS453	Interior Glazed	SB2	CS100-1

Page Left Intentionally Blank

Section B2 Table of Contents











FL300

STOREFRONT SYSTEM

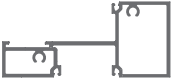
2" x 4½"

	<i>Page</i>
Standard Framing Extrusions.....	1
Optional Framing Extrusions	2-3
Door Framing Extrusions	4
Optional Door Extrusions	5
Accessories.....	6
Steel Reinforcing.....	7
Glazing Infill Charts and Setting Block/Setting Chair Charts	7









Page Left Intentionally Blank

STANDARD FRAMING EXTRUSIONS									
PART DESCRIPTION	PART NO.	PART LENGTH	PCS. PER BOX	FINISH CODE/STOCK LENGTH LIST PRICE					
				#10 CLEAR	#20 BRONZE	#81 WHITE	#2604 POWDER	#2605 POWDER	
 Head/Wall Jamb (Deep Pocket)	FL301	24'	3	\$205	\$222	\$222	\$239	\$263	
 Sill/Optional Head (Deep Pocket)	FL302	24'	4	\$174	\$189	\$189	\$191	\$208	
 Glass Stop	FL303	24'	10	\$46	\$51	\$51	\$88	\$103	
 Shallow Pocket Filler	FL305	24'	10	\$67	\$74	\$74	\$104	\$119	
 Intermediate Horizontal	FL306	24'	3	\$181	\$191	\$191	\$243	\$268	
 Thin Wall Vertical/Wall Jamb	FL304	24'	4	\$152	\$165	\$165	\$206	\$233	
 Expansion Male Mullion (Requires VG10 Gasket Mates w/FL311 Expansion Mullion)	FL310	24'	4	\$152	\$165	\$165	\$196	\$219	
 Expansion Female Mullion (Mates w/FL310 Expansion Mullion)	FL311	24'	4	\$167	\$181	\$181	\$187	\$205	
 Sub-Sill Use ED319-1	FL319	24'	10	\$99	\$107	\$107	\$129	\$144	
 High Performance Sub-Sill Use ED340-1	FL340	24'	10	\$166	\$179	\$179	\$183	\$198	



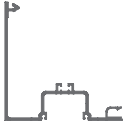



Note: Add Finish Code to the Part Number when ordering (Ex: **FL201-10** for Clear Anodized Finish)

FL300·2" x 4½"

Non-Thermal Screw-Spline Storefront

OPTIONAL FRAMING EXTRUSIONS									
PART DESCRIPTION	PART NO.	PART LENGTH	PCS. PER BOX	FINISH CODE/STOCK LENGTH LIST PRICE					
				#10 CLEAR	#20 BRONZE	#81 WHITE	#2604 POWDER	#2605 POWDER	
 Deep Pocket Filler (Required w/CS135)	FL313	24'	10	\$91	\$100	\$100	\$119	\$135	
 Head/Vertical Mullion	FL314	24'	4	\$172	\$187	\$187	\$221	\$248	
 Standard Vertical Mullion	FL315	24'	4	\$169	\$182	\$182	\$224	\$250	
 Heavy Vertical Mullion	FL316	24'	3	\$246	\$260	\$260	\$298	\$324	
 Single Pocket Corner Post Mullion	FL351	24'	4	\$214	\$230	\$230	\$257	\$283	
 Single Pocket Corner Post Mullion	FL353	24'	4	\$212	\$228	\$228	\$255	\$280	
 90° Corner Post Trim	FL350	24'	4	\$166	\$179	\$179	\$242	\$272	
 Axle Interlock	FL320	24'	4	\$123	\$133	\$133	\$147	\$162	
 135° Corner Post Mullion (Mates w/FL313 Expansion Mullion)	CS135	24'	2	\$267	\$283	\$283	\$322	\$350	



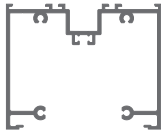



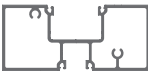

Note: Add Finish Code to the Part Number when ordering (Ex: **FL201-10** for Clear Anodized Finish)

OPTIONAL FRAMING EXTRUSIONS								
PART DESCRIPTION	PART NO.	PART LENGTH	PCS. PER BOX	FINISH CODE/STOCK LENGTH LIST PRICE				
				#10 CLEAR	#20 BRONZE	#81 WHITE	#2604 POWDER	#2605 POWDER
 <p>½" Reveal Adapter (Snap fits with Open Back Wall Jamb/Head Members)</p>	CS102	24'	10	\$89	\$97	\$97	\$118	\$133
 <p>Flat Filler Snap fits with Open Back Wall Jamb/Head Members)</p>	CS104	24'	10	\$66	\$72	\$72	\$107	\$123
 <p>1" Snap-In Pocket Filler</p>	CS106	21'-6"	12	\$25	\$28	\$28	\$68	\$82
 <p>¼" Glass Adapter</p>	CS107	24'	12	\$23	\$29	\$29	\$74	\$90
 <p>Interlocking Stop (Snap fits with CS119 Head Expander - Requires VG10 Gasket)</p>	CS118	24'	10	\$39	\$43	\$43	\$85	\$100
 <p>Head Expander (Snap fits with CS119 Head Expander - Requires VG10 Gasket)</p>	CS119	24'	6	\$110	\$120	\$120	\$136	\$152
 <p>Head/Wall Jamb Anchor Clip</p>	CS300	24'-3"	2	Mill-00	N/A	N/A	N/A	N/A
				\$77				
 <p>Bulk Head Base (4½" x 4¼" for 1" Glazing Requires Two FL303 Glass Stops)</p>	CS453	24'	2	\$312	\$335	\$335	\$339	\$366







Note: Add Finish Code to the Part Number when ordering (Ex: **FL201-10** for Clear Anodized Finish)

FL300·2" x 4½"

Non-Thermal Screw-Spline Storefront

DOOR FRAME EXTRUSIONS									
PART DESCRIPTION	PART NO.	PART LENGTH	PCS. PER BOX	FINISH CODE/STOCK LENGTH LIST PRICE					
				#10 CLEAR	#20 BRONZE	#81 WHITE	#2604 POWDER	#2605 POWDER	
 Door Header for Offset Doors (Requires DS200 Door Stop)	FL307	24'-6"	3	\$244	\$255	\$255	\$339	\$373	
 Door Header for Center Hung Doors (Requires CS112 Cover)	FL308	24'	4	\$169	\$179	\$179	\$248	\$278	
 Open Back Door Jamb for Offset Doors (Requires DS200 Door Stop)	FL309	24'	4	\$162	\$175	\$175	\$227	\$255	
 Tubular Door Header for COC Offset Doors (Requires DS202 Door Stop)	FL312	24'	4	\$234	\$242	\$242	\$370	\$412	
 Open Back Door Jamb Center Hung Doors	FL317	24'	3	\$136	\$147	\$147	\$220	\$251	
 Snap-In Cover for Center Hung Door Header (Mates with FL208 Door Header)	CS112	21'-2"	20	\$70	\$75	\$75	\$112	\$128	
 Snap-In Door Stop for 1" Glass (Requires WP200 Weathering)	DS201	16'	20	\$42	\$47	\$47	\$85	\$101	
 Transom Sash for 1" Glass (Requires FL518 Glass Stop)	CS115	24'	12	\$57	\$62	\$62	\$97	\$112	
 Glass Stop for Transom Sash	FL518	24'	12	\$35	\$38	\$38	\$82	\$98	









Note: Add Finish Code to the Part Number when ordering (Ex: **FL201-10** for Clear Anodized Finish)



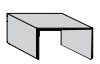
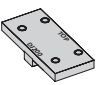





OPTIONAL DOOR EXTRUSIONS									
PART DESCRIPTION		PART NO.	PART LENGTH	PCS. PER BOX	FINISH CODE/STOCK LENGTH LIST PRICE				
					#10 CLEAR	#20 BRONZE	#81 WHITE	#2604 POWDER	#2605 POWDER
	Door Rail Shoe Base	DB124	24'	8	Mill-00	N/A	N/A	N/A	N/A
					\$27				
	1/16" Door Rail Base Extension	DB123	24'	8	\$68	\$73	\$73	\$111	\$126
	Mid Rail Adapter	D113	24"	10	Mill-00	N/A	N/A	N/A	N/A
					\$35				
	4" Muntin or Sidelite Base	D102	16'-0"	4	\$139	\$146	\$146	\$190	\$209
	8" Muntin or Sidelite Base	D108	16'-0"	4	\$223	\$233	\$233	\$316	\$347
	9½" Muntin or Sidelite Base	D109	16'-0"	4	\$271	\$282	\$282	\$387	\$426
	Door Glass Stop for 1/4" Glazing	DG100	16'-0"	20	\$23	\$29	\$29	\$75	\$90
	Door Glass Stop for 1" Glazing	DG101	16'-0"	18	\$20	\$27	\$27	\$72	\$88

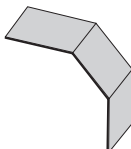

Note: Add Finish Code to the Part Number when ordering (Ex: FL201-10 for Clear Anodized Finish)

FL300·2" x 4½"

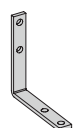
Non-Thermal Screw-Spline Storefront

ACCESSORIES			
PART DESCRIPTION	PART NO.	QTY	PRICE PER BOX
 Spline Screw #14 x 1 HHSTS (Assembly Screw)	AS16	100 (AS16-1)	\$12
 #6 x 3/8" PPH Type AB (Attaches End Dams)	AS21	100 (AS21-1)	\$5
 #10-24 x 3/8" UCPFH (Attaching SR101 or SR102 Steel Reinforcing)	AS24	100 (AS24-1)	\$19
 Setting Chair (Two Per Lite Required at Sill Member)	CS101-1	50 (CS101-2)	\$83
 Drill Jig for Screw Spline (Required for Series FL300 Storefront)	DJ300	1	\$182
 End Dam for FL319 Sub Sill (Requires Two AS21 Screws)	ED319-1	20 (ED319-2)	\$30
 End Dam for FL340 High Performance Sub Sill (Requires Two AS21 Screws)	ED340-1	20 (ED340-2)	\$30
 EPDM Gasket (Standard Gasket for 1/2" Glazing)	NG1	300 FT. (Per Roll)	\$136
 Heavy Glazing Gasket	NG2	500 FT. (Per Roll)	\$342
 3/8" Glazing Gasket	NG3	250 FT. (Per Roll)	\$132
 HD	NG41S	250 FT. (Per Roll)	\$113

ACCESSORIES			
PART DESCRIPTION	PART NO.	QTY	PRICE PER BOX
 4" Long EPDM Setting Block for 1" Glass (Exterior Glazing - Two Per Lite)	SB3	100 (SB3-1)	\$97
 4" Long EPDM Setting Block for Int. Glazing (Horizontal - Two Per Lite)	SB4	100 (SB4-1)	\$265
 Water Diverter (Horizontal - Two Per Lite)	WD300-1	50 (WD300-2)	\$62
 Vinyl Gasket (Standard Weathering Gasket for FL210 and CS118 / CS119)	VG10	250 FT. (VG10-1) (Per Roll)	\$184
 Joint Sealant Tape (1/4" x 1/2" for Sealing Horizontal to Vertical Member Connections)	SM5601	30 FT. (Per Roll)	\$37
 Weathering for D200	WP200	500 FT. (Per Roll)	\$97
 Steel Bracket for Muntin Assembly to Door Stile	TH401	50 (TH401-2)	\$93
 #8 x 3/4" POH TEK Screw	AS7	100 (AS7-1)	\$23

STEEL REINFORCING			
PART DESCRIPTION	PART NO.	QUANTITY LENGTH	PRICE
 1¼" x 4¾" x 10 Ga. Steel Reinforcing (For Standard Vertical Mullions)	SR101	1	\$222
		10'-0"	
 1¼" x 4¾" x 10 Ga. Steel Reinforcing (For Standard Vertical Mullions)	SR102	1	\$129
		10'-0"	

GLAZING INFILL CHART					
SYSTEM	GLAZING ADAPTER	REGLET WIDTH	INFILL THICKNESS	GASKET COMBINATIONS	
FL300	N/A	1⅜"	7/8"	NG2	NG2
			15/16"	NG2	NG1
			1"	NG1	NG1
			1 1/16"	NG1	NG3
			1 7/8"	NG3	NG3

SETTING BLOCK AND SETTING CHAIR CHART					
GLASS SIZE	PART DESCRIPTION	PART NO.	GLAZING APPLICATION	SETTING BLOCK PART NO.	SETTING CHAIR PART NO.
1"	Sill Member	FL302	Exterior Glazed	SB3	CS101-1
		FL303	Interior Glazed	SB4	CS101-1
1"	Intermediate Horizontal	FL306	Exterior Glazed	SB3	Not Required
		FL306	Interior Glazed	SB4	Not Required
1"	Bulk Head Base	CS453	Exterior Glazed	SB3	CS101-1
		CS453	Interior Glazed	SB4	CS101-1

Page Left Intentionally Blank

Section B3 Table of Contents











FL300T

THERMAL STOREFRONT SYSTEM

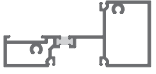
2" x 4½"

	<i>Page</i>
Standard Framing Extrusions.....	1
Optional Framing Extrusions	2-3
Door Framing Extrusions	4
Optional Door Extrusions	5
Accessories.....	6
Steel Reinforcing.....	7
Glazing Infill Charts and Setting Block/Setting Chair Charts	7





Page Left Intentionally Blank

STANDARD FRAMING EXTRUSIONS									
PART DESCRIPTION	PART NO.	PART LENGTH	PCS. PER BOX	FINISH CODE/STOCK LENGTH LIST PRICE					
				#10 CLEAR	#20 BRONZE	#81 WHITE	#2604 POWDER	#2605 POWDER	
 Head/Wall Jamb (Deep Pocket)	FL321T	24'	3	\$237	\$255	\$255	\$269	\$293	
 Sill/Optional Head	FL322T	24'	4	\$180	\$194	\$194	\$200	\$217	
 Glass Stop	FL303	24'	10	\$46	\$51	\$51	\$88	\$103	
 Shallow Pocket Filler	FL325T	24'	10	\$103	\$111	\$111	\$136	\$151	
 Intermediate Horizontal	FL326T	24'	3	\$212	\$223	\$223	\$272	\$297	
 Standard Vertical Mullion	FL334T	24'	4	\$207	\$224	\$224	\$253	\$280	
 Expansion Male Mullion (Requires VG10 Gasket)	FL310T	24'	4	\$176	\$189	\$189	\$221	\$244	
 Expansion Female Mullion (Mates w/FL310 Expansion Mullion)	FL311T	24'	4	\$191	\$206	\$206	\$212	\$230	
 Sub-Sill Use ED319-1	FL339T	24'	10	\$154	\$165	\$165	\$175	\$190	
 High Performance Sub-Sill Use ED340-1	FL340T	24'	10	\$190	\$203	\$203	\$207	\$223	





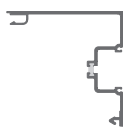
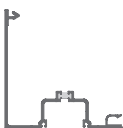
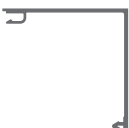

Note: Add Finish Code to the Part Number when ordering (Ex: **FL321T-10** for Clear Anodized Finish)

FL300T·2" x 4½"

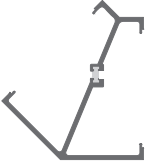
Thermal Screw-Spline Storefront

OPTIONAL FRAMING EXTRUSIONS									
PART DESCRIPTION	PART NO.	PART LENGTH	PCS. PER BOX	FINISH CODE/STOCK LENGTH LIST PRICE					
				#10 CLEAR	#20 BRONZE	#81 WHITE	#2604 POWDER	#2605 POWDER	
 Rotating Mullion (Use with FL320T)	FL331T	24'	10	\$188	\$202	\$202	\$225	\$246	
 Deep Pocket Filler (Required w/CS135)	FL313T	24'	10	\$115	\$124	\$124	\$144	\$159	
 Heavy Vertical Mullion	FL316T	24'	3	\$270	\$285	\$285	\$323	\$349	
 Single Pocket Corner Post Mullion	FL351T	24'	4	\$238	\$255	\$255	\$282	\$307	
 Single Pocket Corner Post Mullion	FL353T	24'	4	\$236	\$252	\$252	\$279	\$305	
 90° Corner Post Trim	FL350	24'	4	\$166	\$179	\$179	\$242	\$272	
 Axle Interlock (Use with FL331T)	FL320T	24'	4	\$147	\$158	\$158	\$172	\$187	



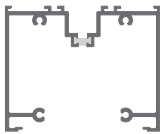



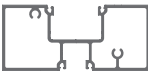

Note: Add Finish Code to the Part Number when ordering (Ex: FL321T-10 for Clear Anodized Finish)

OPTIONAL FRAMING EXTRUSIONS								
PART DESCRIPTION	PART NO.	PART LENGTH	PCS. PER BOX	FINISH CODE/STOCK LENGTH LIST PRICE				
				#10 CLEAR	#20 BRONZE	#81 WHITE	#2604 POWDER	#2605 POWDER
 <p>135° Corner Post Mullion (Use w/FL313T Fillers)</p>	CS135T	24'	2	\$291	\$307	\$307	\$346	\$375
 <p>½" Reveal Adapter (Snap fits with Open Back Wall Jamb/Head Members)</p>	CS102T	24'	10	\$113	\$122	\$122	\$143	\$158
 <p>Flat Filler Snap fits with Open Back Wall Jamb/Head Members)</p>	CS104T	24'	10	\$90	\$96	\$96	\$132	\$147
 <p>1" Snap-In Glazing Pocket Filler</p>	CS106	21'-5"	12	\$25.	\$28	\$28	\$68	\$82
 <p>Interlocking Stop (Snap fits with CS118 interlocking stop)</p>	CS118	24'	10	\$39	\$43	\$43	\$85	\$100
 <p>Head Expander (Snap fits with CS119 Head Expander - Requires VG10 Gasket)</p>	CS119T	24'	6	\$135	\$144	\$144	\$161	\$176
 <p>Head/Wall Jamb Anchor Clip</p>	CS300T	24'-3"	2	Mill-00 101	N/A	N/A	N/A	N/A
 <p>Bulk Head Base (4½" x 4½" for 1" Glazing Requires Two FL303 Glass Stops)</p>	CS453T	24'	2	\$336	\$359	\$359	\$363	\$391







Note: Add Finish Code to the Part Number when ordering (Ex: **FL321T-10** for Clear Anodized Finish)

FL300T·2" x 4½"

Thermal Screw-Spline Storefront

DOOR FRAME EXTRUSIONS									
PART DESCRIPTION	PART NO.	PART LENGTH	PCS. PER BOX	FINISH CODE/STOCK LENGTH LIST PRICE					
				#10 CLEAR	#20 BRONZE	#81 WHITE	#2604 POWDER	#2605 POWDER	
 Door Header for Offset Doors (Requires DS200 Door Stop)	FL307	24'	3	\$244	\$255	\$255	\$339	\$373	
 Door Header for Center Hung Doors (Requires CS112 Cover)	FL308	24'	4	\$169	\$179	\$179	\$248	\$278	
 Open Back Door Jamb for Offset Doors (Requires DS200 Door Stop)	FL309	24'	4	\$162	\$175	\$175	\$227	\$255	
 Tubular Door Header for COC Offset Doors (Requires DS202 Door Stop)	FL312	24'	4	\$234	\$242	\$242	\$370	\$412	
 Open Back Door Jamb Center Hung Doors	FL317	24'	3	\$136	\$147	\$147	\$220	\$251	
 Snap-In Cover for Center Hung Door Header (Mates with FL208 Door Header)	CS112	16'	20	\$70	\$75	\$75	\$112	\$128	
 Snap-In Door Stop for 1" Glass (Requires WP200 Weathering)	DS201	16'	20	\$42	\$47	\$47	\$85	\$101	
 Transom Sash for 1" Glass (Requires FL518 Glass Stop)	CS115	24'	12	\$57	\$62	\$62	\$97	\$112	
 Glass Stop for Transom Sash	FL518	24'	12	\$35	\$38	\$38	\$82	\$98	











Note: Add Finish Code to the Part Number when ordering (Ex: FL321T-10 for Clear Anodized Finish)



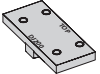





OPTIONAL DOOR EXTRUSIONS									
PART DESCRIPTION		PART NO.	PART LENGTH	PCS. PER BOX	FINISH CODE/STOCK LENGTH LIST PRICE				
					#10 CLEAR	#20 BRONZE	#81 WHITE	#2604 POWDER	#2605 POWDER
	Door Rail Shoe Base	DB124	24'-3"	8	Mill-00	N/A	N/A	N/A	N/A
					\$27				
	1/16" Door Rail Base Extension	DB123	24'-3"	8	\$68	\$73	\$73	\$111	\$126
	Mid Rail Adapter	D113	19'-9"	10	Mill-00	N/A	N/A	N/A	N/A
					\$35				
	4" Muntin or Sidelite Base	D102	16'	4	\$139	\$146	\$146	\$190	209
	7-½" Muntin or Sidelite Base	D108	16'	4	\$223	\$233	\$233	\$316	\$347
	9-½" Muntin or Sidelite Base	D109	16'	4	\$271	\$282	\$282	\$387	\$424
	Door Glass Stop for 1/4" Glazing (Use NG4 Gasket)	DG100	16'	20	\$23	\$29	\$29	\$75	\$90
	Door Glass Stop for 1" Glazing (Use NG41S Gasket)	DG101	16'	18	\$20	\$27	\$27	\$72	\$88

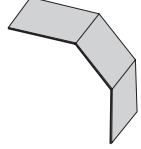

Note: Add Finish Code to the Part Number when ordering (Ex: FL321T-10 for Clear Anodized Finish)

FL300T·2" x 4½"

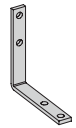
Thermal Screw-Spline Storefront

ACCESSORIES			
PART DESCRIPTION	PART NO.	QTY	PRICE PER BOX
 Spline Screw #14 x 1 HHSTS (Assembly Screw)	AS16	100 (AS16-1)	\$12
 #6 x ¾" PPH Type AB (Attaches End Dams)	AS21	100 (AS21-1)	\$5
 #10-24 x ¾" UCPFH (Attaching SR101 or SR102 Steel Reinforcing)	AS24	100 (AS24-1)	\$19
 Setting Chair (Two Per Lite Required at Sill Member)	CS101-1	50 (CS101-2)	\$83
 Drill Jig for Screw Spline (Required for Series FL300 Storefront)	DJ300	1	\$182
 End Dam for FL319 Sub Sill (Requires Two AS21 Screws)	ED319-1	20 (ED319-2)	\$30
 End Dam for FL340T High Performance Sub Sill (Requires Two AS21 Screws)	ED340-1	20 (ED340-2)	\$30
 EPDM Gasket (Standard Gasket for ¾" Glazing)	NG1	300 FT. (Per Roll)	\$136
 Heavy Glazing Gasket	NG2	500 FT. (Per Roll)	\$342
 ¾" Glazing Gasket	NG3	250 FT. (Per Roll)	\$132

ACCESSORIES			
PART DESCRIPTION	PART NO.	QTY	PRICE PER BOX
 4" Long EPDM Setting Block for 1" Glass (Exterior Glazing - Two Per Lite)	SB3	100 (SB3-1)	\$97
 4" Long EPDM Setting Block for Int. Glazing (Horizontal - Two Per Lite)	SB4	100 (SB4-1)	\$265
 Water Diverter (Horizontal - Two Per Lite)	WD300-1	50 (WD300-2)	\$62
 Vinyl Gasket (Standard Weathering Gasket for FL210 and CS118 / CS119)	VG10	250 FT. (VG10-1) (Per Roll)	\$184
 Joint Sealant Tape (¾" x ½" for Sealing Horizontal to Vertical Member Connections)	SM5601	30 FT. (Per Roll)	\$37
 Weathering for D200	WP200	500 FT. (Per Roll)	\$97
 Steel Bracket for Muntin Assembly to Door Stile	TH401	50 (TH401-2)	\$93
 #8 x ¾" POH TEK Screw	AS7	100 (AS7-1)	\$23

STEEL REINFORCING			
PART DESCRIPTION	PART NO.	QUANTITY LENGTH	PRICE
 1¼" x 4¾" x 10 Ga. Steel Reinforcing (For Standard Vertical Mullions)	SR101	1	\$222
		10'-0"	
 1¼" x 4¾" x 10 Ga. Steel Reinforcing (For Standard Vertical Mullions)	SR102	1	\$129
		10'-0"	

GLAZING INFILL CHART					
SYSTEM	GLAZING ADAPTER	REGLET WIDTH	INFILL THICKNESS	GASKET COMBINATIONS	
FL300T	N/A	1⅜"	⅞"	NG2	NG2
			15/16"	NG2	NG1
			1"	NG1	NG1
			1⅛"	NG1	NG3
			1⅞"	NG3	NG3

SETTING BLOCK AND SETTING CHAIR CHART					
GLASS SIZE	PART DESCRIPTION	PART NO.	GLAZING APPLICATION	SETTING BLOCK PART NO.	SETTING CHAIR PART NO.
1"	Sill Member	FL322T	Exterior Glazed	SB3	CS101-1
		FL303	Interior Glazed	SB4	CS101-1
1"	Intermediate Horizontal	FL326T	Exterior Glazed	SB3	Not Required
		FL306	Interior Glazed	SB4	Not Required
1"	Bulk Head Base	CS453T	Exterior Glazed	SB3	CS101-1
		CS453T	Interior Glazed	SB4	CS101-1

Page Left Intentionally Blank











Section B4 Table of Contents

FS400T THERMAL STOREFRONT SYSTEM

2" x 4½"
Front Set

	<i>Page</i>
Standard Framing Extrusions Exterior Glazed System	1
Standard Framing Extrusions Interior Glazed System	2
Accessories	3
Steel Reinforcing.....	4
Glazing Infill Charts and Setting Block/Setting Chair Charts	4

Page Left Intentionally Blank











STANDARD FRAMING EXTRUSIONS - EXTERIOR GLAZED SYSTEM									
PART DESCRIPTION	PART NO.	PART LENGTH	PCS. PER BOX	FINISH CODE/STOCK LENGTH LIST PRICE					
				#11 CLEAR	#21 BRONZE	#81 WHITE	#2604 POWDER	#2605 POWDER	
 Head Exterior Glazed	FS402T Thermal	24'	4	\$212	\$228	\$223	\$216	\$233	
 Sill Exterior Glazed <small>(Use CS403 Stop)</small>	FS409T Thermal	24'	4	\$194	\$209	\$204	\$198	\$213	
 Glass Stop Exterior Glaze	CS403	24'	12	\$27	\$33	\$32	\$77	\$93	
 Flat Filler	FS405	24'	10	\$38	\$42	\$41	\$85	\$100	
 Intermediate Horizontal Exterior Glazed <small>(Use CS403 Stop)</small>	FS408T Thermal	24'	4	\$208	\$223	\$218	\$235	\$256	
 Wall Jamb	FS407T Thermal	24'	3	\$186	\$200	\$196	\$227	\$251	
 Standard Vertical Mullion	FS404T Thermal	24'	4	\$198	\$214	\$209	\$239	\$263	
 Expansion Male Mullion <small>Mates with FS411T</small>	FS410T Thermal	24'	4	\$131	\$140	\$137	\$156	\$171	
 Expansion Female Mullion <small>(Use VG10 Gasket) Mates with FS410T</small>	FS411T Thermal	24'	4	\$185	\$198	\$194	\$225	\$249	
 Sub-Sill Flashin	FL339T Thermal Thermal	24'	10	\$158	\$169	\$165	\$175	\$190	

Note: Add Finish Code to the Part Number when ordering (Ex: **FS401T-10** for Clear Anodized Finish)









FS400T·2"x4½"

Thermal Screw-Spline Storefront

STANDARD FRAMING EXTRUSIONS - INTERIOR GLAZED SYSTEM

PART DESCRIPTION	PART NO.	PART LENGTH	PCS. PER BOX	FINISH CODE/STOCK LENGTH LIST PRICE				
				#11 CLEAR	#21 BRONZE	#81 WHITE	#2604 POWDER	#2605 POWDER
 Head Interior Glazed (Use with FS403 Stop)	FS401T Thermal	24'	3	\$179	\$193	\$189	\$188	\$203
 Sill Interior Glazed	FS402T Thermal	24'	4	\$212	\$228	\$223	\$216	\$233
 Glass Stop Interior Glazed	FS403	24'	10	\$67	\$74	\$72	\$103	\$118
 Flat Filler	FS405	24'	10	\$38	\$42	\$41	\$85	\$100
 Intermediate Horizontal Interior Glazed (Use SB12 Setting Block and FS403 Stop)	FS406T Thermal	24'	3	\$212	\$223	\$218	\$251	\$273
 Wall Jamb	FS407T Thermal	24'	3	\$186	\$200	\$196	\$227	\$251
 Standard Vertical Mullion	FS404T Thermal	24'	4	\$198	\$214	\$209	\$239	\$263
 Expansion Male Mullion Mates with FS411T	FS410T Thermal	24'	4	\$131	\$140	\$137	\$156	\$171
 Expansion Female Mullion (Mates w/FS410T Expansion Mullion) (Use VG10 Gasket)	FS411T Thermal	24'	4	\$185	\$198	\$194	\$225	\$249
 Sub-Sill Flashing	FL339T Thermal	24'	10	\$158	\$169	\$165	\$175	\$190









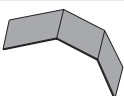
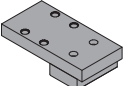

Note: Add Finish Code to the Part Number when ordering (Ex: **FL401T-10** for Clear Anodized Finish)

DOOR FRAMING EXTRUSIONS								
PART DESCRIPTION	PART NO.	PART LENGTH	PCS. PER BOX	FINISH CODE/STOCK LENGTH LIST PRICE				
				#10 CLEAR	#20 BRONZE	#81 WHITE	#2604 POWDER	#2605 POWDER
 Frame Jamb / Header / Transom Bar for Surface Mount Closer (11 & 21 Finish)	FS419	24'	2	\$223	\$233	\$228	\$289	\$318
 Flat Filler (11 & 21 Finish)	FS405	24'	10	\$38	\$42	\$41	\$85	\$100
 Transom Sash (Use CS111 Glass Stop)	CS110	24'	12	\$29	\$33	\$33	\$79	\$94
 Transom Glass Stop (Use NG1)	CS111	24'	12	\$24	\$30	\$30	\$75	\$91
 Clip Applied Door Stop (Use WP200 Pile with DH-MC175 Clip)	DS158	24'	10	\$36	\$40	\$40	\$83	\$98
 Transom Header COC Double Acting	FL308	24'	4	\$169	\$179	\$179	\$248	\$278
 Transom Header Filler	CS112	24'	20	\$70	\$75	\$75	\$112	\$128
 Door Header / Transom Bar (11 & 21 Finish)	FL312	24'	4	\$239	\$247	\$242	\$370	\$412
 Door Stop (Use with FL312) (Use WP200 Pile)	DS202	24'	5	\$78	\$84	\$84	\$137	\$157

Note: Add Finish Code to the Part Number when ordering (Ex: **FL401T-10** for Clear Anodized Finish)

FS400T·2" x 4½"

Thermal Screw-Spline Storefront

ACCESSORIES			
PART DESCRIPTION	PART NO.	QUANTITY	PRICE PER BOX
 Spline Screw #14 x 1 HHSTS (Assembly Screw)	AS16	100 (AS16-1)	\$12
 #6 x ¾" PPH Type AB (Attaches End Dams)	AS21	100 (AS21-1)	\$5
 Water Diverter (Use at Intermediate Horizontals)	WD300-1	50 (WD300-2)	\$40
 Drill Jig for Screw Spline (Required for Series FS400T Storefront)	DJ401	1	\$188
 End Dam for Sub Sill Flashing	ED319-1	20 (ED319-2)	\$30
 EPDM Gasket	NG1	300 FT. (Per Roll)	\$136
 Setting Block	SB3	100 (SB3-1)	\$97
 Setting Block (Intermediate Horizontal Inside Glaze)	SB12	100 (SB12-1)	\$49
 Expansion Mullion Gasket (Use with FS411T)	VG10	250 FT. (VG10-1) (Per Roll)	\$184
 Joint Sealant Tape (¼" x ½" for Sealing Horizontal to Vertical Member Connections)	SM5601	30 FT. (Per Roll)	\$37
 Screw (Use with DH-MC175 Clip)	AS7	100	\$23
 Weather Stripping	WP200	500 FT.	\$97

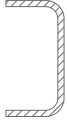
STEEL REINFORCING			
PART DESCRIPTION	PART NO.	QUANTITY	PRICE
 2½" x 1¼" x 10 Ga. Steel Reinforcing (For Standard Vertical Mullions)	SR404	1	\$153
		10'-0"	

GLAZING INFILL CHART					
SYSTEM	GLAZING ADAPTER	REGLET WIDTH	INFILL THICKNESS	GASKET COMBINATIONS	
FS400T	N/A	1¾"	⅞"	NG2	NG2
			15/16"	NG2	NG1
			1"	NG1	NG1

SETTING BLOCK AND SETTING CHAIR CHART					
GLASS SIZE	PART DESCRIPTION	PART NO.	GLAZING APPLICATION	SETTING BLOCK PART NO.	SETTING CHAIR PART NO.
1"	Sill Member	FS409	Exterior Glazed	SB3	Not Required
		FS402	Interior Glazed	SB3	Not Required
1"	Intermediate Horizontal	FS408	Exterior Glazed	SB3	Not Required
		FS406	Interior Glazed	SB12	Not Required











Page Left Intentionally Blank

Section B5 Table of Contents

Angles, Channels, Flat Bars, and Tubes

	<i>Page</i>
MISC PARTS - Angles, Channels, Bars, and Tubes	1

Page Left Intentionally Blank

STANDARD FRAMING EXTRUSIONS								
PART DESCRIPTION	PART NO.	PART LENGTH	PCS. PER BOX	FINISH CODE/STOCK LENGTH LIST PRICE				
				#10 CLEAR	#20 BRONZE	#81 WHITE	#2604 POWDER	#2605 POWDER
 1" x 1" x 1/8" Angle	A100	21'	12	\$43	\$50			
 1 1/2" x 1 1/2" x 1/8" Angle	A150	21'	12	\$65	\$70			
 1 1/2" x 1" x 1/8" Angle	A151	21'	12	\$54	\$60			
 1 3/4" x 1 3/4" x 1/8" Angle	A175	21'	12	\$76	\$81			
 1/2" x 1/2" Bar	B1	21'	12	\$42	\$52			
 5/16" x 2" Bar	B2	21'	12	\$96	\$104			
 1/2" x 1 1/2" Bar	B3	21'	12	\$122	\$129			
 1" x 1" x 1/8" Channel	CH100	21'	12	\$62	\$67			
 1" x 1" x 1/8" Tube	H100	21'	12	\$81	\$85			
 1 3/4" x 1 3/4" x 7/64" Tube	H175	21'	12	\$129	\$137			
 2" x 2" x 1/8" Tube	H200	21'	12	\$162	\$167			

Default Finish is #10 unless otherwise specified

Note: Add Finish Code to the Part Number when ordering (Ex: A100-10 for Clear Anodized Finish)

Page Left Intentionally Blank

Section B6
Table of Contents





FL100

REMOVABLE OFFICE PARTITIONS

1³/₈" X 2¹/₂"

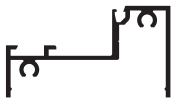



	<i>Page</i>
Standard Framing Extrusions.....	1
Optional Framing Extrusions	3
Door Framing Extrusions	5
Accessories.....	7

Page Left Intentionally Blank

STANDARD FRAMING EXTRUSIONS								
PART DESCRIPTION	PART NO.	PART LENGTH	PCS. PER BOX	FINISH CODE/STOCK LENGTH LIST PRICE				
				#10 CLEAR	#20 BRONZE	#81 WHITE	#2604 POWDER	#2605 POWDER
 <p>Sill/Head/Intermediate Horizontal</p>	FL102	24'	4	\$106	\$115	\$106	\$137	NA
 <p>Glass Stop</p>	FL103	24'	10	\$33	\$37	\$58	\$89	NA
 <p>Shallow Pocket Filler</p>	FL105	24'	10	\$55	\$61	\$72	\$103	NA
 <p>Standard Vertical Mullion</p>	FL104	24'	4	\$124	\$135	\$122	\$158	NA



Note: Add Finish Code to the Part Number when ordering (Ex: **FL104-10** for Clear Anodized Finish)

Page Left Intentionally Blank

OPTIONAL FRAMING EXTRUSIONS									
PART DESCRIPTION	PART NO.	PART LENGTH	PCS. PER BOX	FINISH CODE/STOCK LENGTH LIST PRICE					
				#10 CLEAR	#20 BRONZE	#81 WHITE	#2604 POWDER	#2605 POWDER	
 <p>Interlocking Stop (Snap fits with CS019 Head Expander - Requires VG10 Gasket)</p>	CS018	24'	10	\$35	\$39	\$60	\$91	NA	
 <p>Head Expander (Snap fits with CS018 Head Expander - Requires VG10 Gasket)</p>	CS019	24'	6	\$79	\$86	\$89	\$120	NA	
 <p>Wall Cover 4 ³/₈ "</p>	FL155	24'	4	\$188	\$203	\$204	\$266	NA	
 <p>Wall Cover 4 ³/₈ "</p>	FL157	24'	4	\$193	\$208	\$207	\$268	NA	



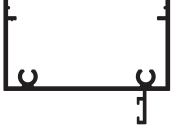
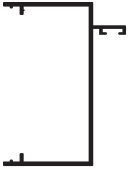

Note: Add Finish Code to the Part Number when ordering (Ex: **FL157-10** for Clear Anodized Finish)

Page Left Intentionally Blank

DOOR FRAME EXTRUSIONS								
PART DESCRIPTION	PART NO.	PART LENGTH	PCS. PER BOX	FINISH CODE/STOCK LENGTH LIST PRICE				
				#10 CLEAR	#20 BRONZE	#81 WHITE	#2604 POWDER	#2605 POWDER
 Door Header	FL107	24'	3	\$110	\$120	\$132	\$182	NA
 Door Jamb	FL109	24'	4	\$94	\$103	\$121	\$171	NA
 Door Jamb / Header Center Hung Doors	FL117	24'	3	\$100	\$109	\$115	\$156	NA

Note: Add Finish Code to the Part Number when ordering (Ex: FL117-10 for Clear Anodized Finish)

Page Left Intentionally Blank

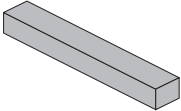
ACCESSORIES			
PART DESCRIPTION	PART NO.	QTY	PRICE PER BOX
 <p>Spline Screw #8 x 1 PHSTS (Assembly Screw)</p>	AS62	100 (AS62-1)	\$25
 <p>Glazing Gasket 3/8 Infill</p>	NG1	300 FT. (Per Roll)	\$136
 <p>Glazing Gasket 1/4 Infill</p>	NG2	500 FT. (Per Roll)	\$342
 <p>Glazing Gasket 1/2 Infill</p>	NG3	250 FT. (Per Roll)	\$132
 <p>4" Long EPDM Setting Block for 1/4" Glass (Exterior Glazing - Two Per Lite)</p>	SB10	100 (SB10-1)	\$197

Page Left Intentionally Blank

Section B7
Table of Contents







FL600

STOREFRONT SYSTEM

2¼" x 6"

	<i>Page</i>
Standard Framing Extrusions.....	1
Optional Framing Extrusions	2
Door Framing Extrusions	3
Optional Door Extrusions	4
Accessories.....	5

Page Left Intentionally Blank



STANDARD FRAMING EXTRUSIONS									
PART DESCRIPTION	PART NO.	PART LENGTH	PCS. PER BOX	FINISH CODE/STOCK LENGTH LIST PRICE					
				#10 CLEAR	#20 BRONZE	#81 WHITE	#2604 POWDER	#2605 POWDER	
 <p>Head / Vertical / Jamb</p>	FL634	24'	4	\$298	\$321	\$321	\$368	\$401	
 <p>Sill / Intermediate Horizontal</p>	FL626	24'	3	\$341	\$355	\$355	\$442	\$476	
 <p>Glass Stop</p>	FL303	24'	10	\$46	\$51	\$51	\$88	\$103	
 <p>Shallow Pocket Filler</p>	FL625	24'	10	\$147	\$160	\$160	\$183	\$200	
 <p>Expansion Mullion (Requires VG10 Gasket)</p>	FL610	24'	4	\$236	\$255	\$255	\$302	\$331	
 <p>Expansion Female Mullion (Mates w/FL610 Expansion Mullion)</p>	FL611	24'	4	\$265	\$286	\$286	\$344	\$376	
 <p>Sub-Sill Flashing</p>	FL639	24'	10	\$245	\$264	\$264	\$274	\$295	

Note: Add Finish Code to the Part Number when ordering (Ex: **FL610T-10** for Clear Anodized Finish)







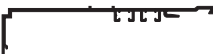

FL600·2¼" x 6"

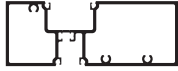
Screw-Spline Storefront

OPTIONAL FRAMING EXTRUSIONS

PART DESCRIPTION	PART NO.	PART LENGTH	PCS. PER BOX	FINISH CODE/STOCK LENGTH LIST PRICE				
				#10 CLEAR	#20 BRONZE	#81 WHITE	#2604 POWDER	#2605 POWDER
 <p>Flat Filler Snap fits with Open Back Wall Jamb/Head Members)</p>	CS604	24'	10	\$142	\$154	\$154	\$187	\$205
 <p>Interlocking Stop (Snap fits with CS118 interlocking stop)</p>	CS118	24'	10	\$39	\$43	\$43	\$85	\$100
 <p>Head Expander (Snap fits with CS119 Head Expander - Requires VG10 Gasket)</p>	CS619	24'	6	\$169	\$182	\$182	\$178	\$191







Note: Add Finish Code to the Part Number when ordering (Ex: **CS604T-10** for Clear Anodized Finish)

DOOR FRAME EXTRUSIONS								
PART DESCRIPTION	PART NO.	PART LENGTH	PCS. PER BOX	FINISH CODE/STOCK LENGTH LIST PRICE				
				#10 CLEAR	#20 BRONZE	#81 WHITE	#2604 POWDER	#2605 POWDER
 Door Header for Offset Doors (Requires DS200 Door Stop)	FL607	24'	3	\$396	\$411	\$411	\$535	\$578
 Door Jamb for Offset Doors (Requires DS200 Door Stop)	FL609	24'	4	\$258	\$277	\$277	\$351	\$385
 Door Header for COC Offset Doors (Requires DS202 Door Stop) (Note: 2"x6" Doorframe Header Profile)	FL612	24'	4	\$308	\$318	\$318	\$477	\$519
 Heavy Wall Door Jamb	FL649	24'	3	\$332	\$351	\$351	\$385	\$413
 Snap-In Door Stop (Requires WP200 Weathering)	DS200	16'	20	\$31	\$34	\$34	\$72	\$86
 Transom Sash for 1" Glass (Requires FL518 Glass Stop)	CS115	24'	12	\$29	\$33	\$33	\$79	\$94
 Glass Stop for Transom Sash	FL518	24'	12	\$24	\$30	\$30	\$75	\$91
 Door Stop (Use with FL612) (Use WP200 Pile)	DS202	24'	5	\$78	\$84	\$84	\$137	\$157
 Door Stop Thermal Door	DS600	16'	10	\$29	\$32	\$32	\$57	\$66







Note: Add Finish Code to the Part Number when ordering (Ex: **FL612T-10** for Clear Anodized Finish)





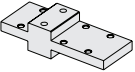

FL600·2¼" x 6"

Screw-Spline Storefront

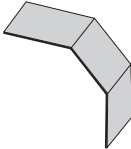
OPTIONAL DOOR EXTRUSIONS									
PART DESCRIPTION	PART NO.	PART LENGTH	PCS. PER BOX	FINISH CODE/STOCK LENGTH LIST PRICE					
				#10 CLEAR	#20 BRONZE	#81 WHITE	#2604 POWDER	#2605 POWDER	
 Door Rail Shoe Base	DB124	24'-3"	8	Mill-00	N/A	N/A	N/A	N/A	N/A
				\$27					
 ¼" Door Rail Base Extension	DB123	24'-3"	8	\$68	\$73	\$73	\$111	\$126	
 Mid Rail Adapter	D113	19'-9"	10	Mill-00	N/A	N/A	N/A	N/A	N/A
				\$35					
	4" Muntin or Sidelite Base	D102	16'	4	\$139	\$146	\$146	\$190	209
	7-½" Muntin or Sidelite Base	D108	16'	4	\$223	\$233	\$233	\$316	\$347
	9-½" Muntin or Sidelite Base	D109	16'	4	\$271	\$282	\$282	\$387	\$424
 Door Glass Stop for ¼" Glazing (Use NG4 Gasket)	DG100	16'	20	\$23	\$29	\$29	\$75	\$90	
 Door Glass Stop for 1" Glazing (Use NG41S Gasket)	DG101	16'	18	\$20	\$27	\$27	\$72	\$88	

Note: Add Finish Code to the Part Number when ordering (Ex: **FL321T-10** for Clear Anodized Finish)

ACCESSORIES			
PART DESCRIPTION	PART NO.	QTY	PRICE PER BOX
 Spline Screw #14 x 1 HHSTS (Assembly Screw)	AS16	100 (AS16-1)	\$12
 #6 x ¾" PPH Type AB (Attaches End Dams)	AS21	100 (AS21-1)	\$5
 #10-24 x ¾" UCPFH (Attaching SR101 or SR102 Steel Reinforcing)	AS24	100 (AS24-1)	\$19
 Drill Jig for Screw Spline (Required for Series FL600 Storefront)	DJ600	1	\$355
 End Dam for Sill Flashing (Requires Two AS21 Screws)	ED639-1	20 (ED639-2)	\$35
 EPDM Gasket (Standard Gasket for ¼" Glazing)	NG1	300 FT. (Per Roll)	\$136
 Heavy Glazing Gasket	NG2	500 FT. (Per Roll)	\$342
 ¾" Glazing Gasket	NG3	250 FT. (Per Roll)	\$132

ACCESSORIES			
PART DESCRIPTION	PART NO.	QTY	PRICE PER BOX
 4" Long EPDM Setting Block for 1" Glass (Exterior Glazing - Two Per Lite)	SB3	100 (SB3-1)	\$97
 Water Diverter (Horizontal - Two Per Lite)	WD300-1	50 (WD300-2)	\$62
 Vinyl Gasket (Standard Weathering Gasket for FL210 and CS118 / CS119)	VG10	250 FT. (VG10-1) (Per Roll)	\$49
 Joint Sealant Tape (½" x ½" for Sealing Horizontal to Vertical Member Connections)	SM5601	30 FT. (Per Roll)	\$37
 Weathering for D200	WP200	500 FT. (Per Roll)	\$97
 Steel Bracket for Muntin Assembly to Door Stile	TH401	50 (TH401-2)	\$93
 #8 x ¾" POH TEK Screw	AS7	100 (AS7-1)	\$23

Page Left Intentionally Blank

Section B8 Table of Contents







FL600T

THERMAL STOREFRONT SYSTEM

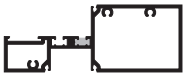
2¼" x 6"

	<i>Page</i>
Standard Framing Extrusions.....	1
Optional Framing Extrusions	2
Door Framing Extrusions	3
Optional Door Extrusions	4
Accessories.....	5

Page Left Intentionally Blank



STANDARD FRAMING EXTRUSIONS									
PART DESCRIPTION	PART NO.	PART LENGTH	PCS. PER BOX	FINISH CODE/STOCK LENGTH LIST PRICE					
				#10 CLEAR	#20 BRONZE	#81 WHITE	#2604 POWDER	#2605 POWDER	
 Head / Vertical / Jamb	FL634T	24'	4	\$325	\$348	\$348	\$421	\$456	
 Sill / Intermediate Horizontal	FL626T	24'	3	\$368	\$382	\$382	\$501	\$537	
 Glass Stop	FL303	24'	10	\$46	\$51	\$51	\$88	\$103	
 Shallow Pocket Filler	FL625T	24'	10	\$174	\$187	\$187	\$223	\$242	
 Expansion Mullion (Requires VG10 Gasket)	FL610T	24'	4	\$263	\$282	\$282	\$351	\$382	
 Expansion Female Mullion (Mates w/FL610 Expansion Mullion)	FL611T	24'	4	\$292	\$313	\$313	\$395	\$430	
 Sub-Sill Flashing	FL639T	24'	10	\$272	\$291	\$291	\$321	\$343	

Note: Add Finish Code to the Part Number when ordering (Ex: **FL610T-10** for Clear Anodized Finish)







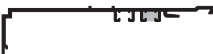

FL600T·2¼" x 6"

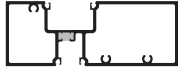
Thermal Screw-Spline Storefront

OPTIONAL FRAMING EXTRUSIONS

PART DESCRIPTION	PART NO.	PART LENGTH	PCS. PER BOX	FINISH CODE/STOCK LENGTH LIST PRICE				
				#10 CLEAR	#20 BRONZE	#81 WHITE	#2604 POWDER	#2605 POWDER
 <p>Flat Filler Snap fits with Open Back Wall Jamb/Head Members)</p>	CS604T	24'	10	\$169	\$181	\$181	\$227	\$247
 <p>Interlocking Stop (Snap fits with CS118 interlocking stop)</p>	CS118	24'	10	\$39	\$43	\$43	\$85	\$100
 <p>Head Expander (Snap fits with CS119 Head Expander - Requires VG10 Gasket)</p>	CS619T	24'	6	\$196	\$209	\$209	\$218	\$232

Note: Add Finish Code to the Part Number when ordering (Ex: **CS604T-10** for Clear Anodized Finish)







DOOR FRAME EXTRUSIONS								
PART DESCRIPTION	PART NO.	PART LENGTH	PCS. PER BOX	FINISH CODE/STOCK LENGTH LIST PRICE				
				#10 CLEAR	#20 BRONZE	#81 WHITE	#2604 POWDER	#2605 POWDER
 Door Header for Offset Doors (Requires DS200 Door Stop)	FL607T	24'	3	\$423	\$438	\$438	\$600	\$647
 Door Jamb for Offset Doors (Requires DS200 Door Stop)	FL609T	24'	4	\$285	\$304	\$304	\$403	\$440
 Door Header for COC Offset Doors (Requires DS202 Door Stop) (Note: 2"x6" Doorframe Header Profile)	FL612	24'	4	\$308	\$318	\$318	\$477	\$519
 Heavy Wall Door Jamb	FL649T	24'	3	\$322	\$351	\$351	\$440	\$469
 Snap-In Door Stop (Requires WP200 Weathering)	DS200	16'	20	\$31	\$34	\$34	\$72	\$86
 Transom Sash for 1" Glass (Requires FL518 Glass Stop)	CS115	24'	12	\$29	\$33	\$33	\$79	\$94
 Glass Stop for Transom Sash	FL518	24'	12	\$24	\$30	\$30	\$75	\$91
 Door Stop (Use with FL612) (Use WP200 Pile)	DS202	24'	5	\$78	\$84	\$84	\$137	\$157
 Door Stop Thermal Door	DS600	16'	10	\$29	\$32	\$32	\$57	\$66

Note: Add Finish Code to the Part Number when ordering (Ex: **FL612T-10** for Clear Anodized Finish)







FL600T·2¼" x 6"





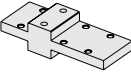

Thermal Screw-Spline Storefront

OPTIONAL DOOR EXTRUSIONS

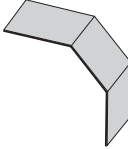
PART DESCRIPTION	PART NO.	PART LENGTH	PCS. PER BOX	FINISH CODE/STOCK LENGTH LIST PRICE					
				#10 CLEAR	#20 BRONZE	#81 WHITE	#2604 POWDER	#2605 POWDER	
 Door Rail Shoe Base	DB124	24'-3"	8	Mill-00	N/A	N/A	N/A	N/A	
				\$27					
 ¼" Door Rail Base Extension	DB123	24'-3"	8	\$68	\$73	\$73	\$111	\$126	
 Mid Rail Adapter	D113	19'-9"	10	Mill-00	N/A	N/A	N/A	N/A	
				\$35					
	4" Muntin or Sidelite Base	D102	16'	4	\$139	\$146	\$146	\$190	209
	7-½" Muntin or Sidelite Base	D108	16'	4	\$223	\$233	\$233	\$316	\$347
	9-½" Muntin or Sidelite Base	D109	16'	4	\$271	\$282	\$282	\$387	\$424
 Door Glass Stop for ¼" Glazing (Use NG4 Gasket)	DG100	16'	20	\$23	\$29	\$29	\$75	\$90	
 Door Glass Stop for 1" Glazing (Use NG41S Gasket)	DG101	16'	18	\$20	\$27	\$27	\$72	\$88	

Note: Add Finish Code to the Part Number when ordering (Ex: **FL321T-10** for Clear Anodized Finish)

ACCESSORIES			
PART DESCRIPTION	PART NO.	QTY	PRICE PER BOX
 Spline Screw #14 x 1 HHSTS (Assembly Screw)	AS16	100 (AS16-1)	\$12
 #6 x ¾" PPH Type AB (Attaches End Dams)	AS21	100 (AS21-1)	\$5
 #10-24 x ¾" UCPFH (Attaching SR101 or SR102 Steel Reinforcing)	AS24	100 (AS24-1)	\$19
 Drill Jig for Screw Spline (Required for Series FL600 Storefront)	DJ600	1	\$355
 End Dam for Sill Flashing (Requires Two AS21 Screws)	ED639-1	20 (ED639-2)	\$35
 EPDM Gasket (Standard Gasket for ¼" Glazing)	NG1	300 FT. (Per Roll)	\$136
 Heavy Glazing Gasket	NG2	500 FT. (Per Roll)	\$342
 ¾" Glazing Gasket	NG3	250 FT. (Per Roll)	\$132

ACCESSORIES			
PART DESCRIPTION	PART NO.	QTY	PRICE PER BOX
 4" Long EPDM Setting Block for 1" Glass (Exterior Glazing - Two Per Lite)	SB3	100 (SB3-1)	\$97
 Water Diverter (Horizontal - Two Per Lite)	WD300-1	50 (WD300-2)	\$62
 Vinyl Gasket (Standard Weathering Gasket for FL210 and CS118 / CS119)	VG10	250 FT. (VG10-1) (Per Roll)	\$49
 Joint Sealant Tape (½" x ½" for Sealing Horizontal to Vertical Member Connections)	SM5601	30 FT. (Per Roll)	\$37
 Weathering for D200	WP200	500 FT. (Per Roll)	\$97
 Steel Bracket for Muntin Assembly to Door Stile	TH401	50 (TH401-2)	\$93
 #8 x ¾" POH TEK Screw	AS7	100 (AS7-1)	\$23

Page Left Intentionally Blank







Section B9
Table of Contents

FL600UT
THERMAL STOREFRONT SYSTEM

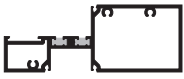
2¼" x 6"

	<i>Page</i>
Standard Framing Extrusions.....	1
Optional Framing Extrusions	2
Door Framing Extrusions	3
Optional Door Extrusions	4
Accessories.....	5

Page Left Intentionally Blank



STANDARD FRAMING EXTRUSIONS									
PART DESCRIPTION	PART NO.	PART LENGTH	PCS. PER BOX	FINISH CODE/STOCK LENGTH LIST PRICE					
				#10 CLEAR	#20 BRONZE	#81 WHITE	#2604 POWDER	#2605 POWDER	
 Head / Vertical / Jamb	FL634U	24'	4	\$352	\$375	\$448	\$483	\$448	
 Sill / Intermediate Horizontal	FL626U	24'	3	\$395	\$409	\$528	\$564	\$528	
 Glass Stop	FL303	24'	10	\$46	\$51	\$51	\$88	\$103	
 Shallow Pocket Filler	FL625U	24'	10	\$201	\$214	\$250	\$269	\$250	
 Expansion Mullion (Requires VG10 Gasket)	FL610U	24'	4	\$290	\$309	\$378	\$409	\$378	
 Expansion Female Mullion (Mates w/FL610 Expansion Mullion)	FL611U	24'	4	\$319	\$340	\$422	\$457	\$422	
 Sub-Sill Flashing	FL639U	24'	10	\$245	\$264	\$348	\$370	\$348	

Note: Add Finish Code to the Part Number when ordering (Ex: **FL610U-10** for Clear Anodized Finish)







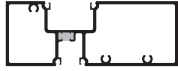

FL600UT·2¼" x 6"

Thermal Screw-Spline Storefront

OPTIONAL FRAMING EXTRUSIONS

PART DESCRIPTION	PART NO.	PART LENGTH	PCS. PER BOX	FINISH CODE/STOCK LENGTH LIST PRICE				
				#10 CLEAR	#20 BRONZE	#81 WHITE	#2604 POWDER	#2605 POWDER
 <p>Flat Filler Snap fits with Open Back Wall Jamb/Head Members)</p>	CS604U	24'	10	\$196	\$208	\$217	\$232	\$217
 <p>Interlocking Stop (Snap fits with CS118 interlocking stop)</p>	CS118	24'	10	\$39	\$43	\$43	\$85	\$100
 <p>Head Expander (Snap fits with CS119 Head Expander - Requires VG10 Gasket)</p>	CS619U	24'	6	\$223	\$236	\$245	\$259	\$245

Note: Add Finish Code to the Part Number when ordering (Ex: **CS604U-10** for Clear Anodized Finish)







DOOR FRAME EXTRUSIONS								
PART DESCRIPTION	PART NO.	PART LENGTH	PCS. PER BOX	FINISH CODE/STOCK LENGTH LIST PRICE				
				#10 CLEAR	#20 BRONZE	#81 WHITE	#2604 POWDER	#2605 POWDER
 Door Header for Offset Doors (Requires DS200 Door Stop)	FL607T	24'	3	\$423	\$438	\$438	\$600	\$647
 Door Jamb for Offset Doors (Requires DS200 Door Stop)	FL609T	24'	4	\$285	\$304	\$304	\$403	\$440
 Door Header for COC Offset Doors (Requires DS202 Door Stop) (Note: 2"×6" Doorframe Header Profile)	FL612	24'	4	\$308	\$318	\$318	\$477	\$519
 Heavy Wall Door Jamb	FL649T	24'	3	\$322	\$351	\$351	\$440	\$469
 Snap-In Door Stop (Requires WP200 Weathering)	DS200	16'	20	\$31	\$34	\$34	\$72	\$86
 Transom Sash for 1" Glass (Requires FL518 Glass Stop)	CS115	24'	12	\$29	\$33	\$33	\$79	\$94
 Glass Stop for Transom Sash	FL518	24'	12	\$24	\$30	\$30	\$75	\$91
 Door Stop (Use with FL612) (Use WP200 Pile)	DS202	24'	5	\$78	\$84	\$84	\$137	\$157
 Door Stop Thermal Door	DS600	16'	10	\$29	\$32	\$32	\$57	\$66

Note: Add Finish Code to the Part Number when ordering (Ex: **FL612-10** for Clear Anodized Finish)







FL600UT·2¼" x 6"





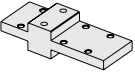

Thermal Screw-Spline Storefront

OPTIONAL DOOR EXTRUSIONS

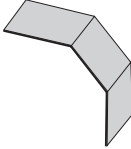
PART DESCRIPTION	PART NO.	PART LENGTH	PCS. PER BOX	FINISH CODE/STOCK LENGTH LIST PRICE					
				#10 CLEAR	#20 BRONZE	#81 WHITE	#2604 POWDER	#2605 POWDER	
 Door Rail Shoe Base	DB124	24'-3"	8	Mill-00	N/A	N/A	N/A	N/A	
				\$27					
 ¼" Door Rail Base Extension	DB123	24'-3"	8	\$68	\$73	\$73	\$111	\$126	
 Mid Rail Adapter	D113	19'-9"	10	Mill-00	N/A	N/A	N/A	N/A	
				\$35					
	4" Muntin or Sidelite Base	D102	16'	4	\$139	\$146	\$146	\$190	209
	7-½" Muntin or Sidelite Base	D108	16'	4	\$223	\$233	\$233	\$316	\$347
	9-½" Muntin or Sidelite Base	D109	16'	4	\$271	\$282	\$282	\$387	\$424
 Door Glass Stop for ¼" Glazing (Use NG4 Gasket)	DG100	16'	20	\$23	\$29	\$29	\$75	\$90	
 Door Glass Stop for 1" Glazing (Use NG41S Gasket)	DG101	16'	18	\$20	\$27	\$27	\$72	\$88	

Note: Add Finish Code to the Part Number when ordering (Ex: **FL321T-10** for Clear Anodized Finish)

ACCESSORIES			
PART DESCRIPTION	PART NO.	QTY	PRICE PER BOX
 Spline Screw #14 x 1 HHSTS (Assembly Screw)	AS16	100 (AS16-1)	\$12
 #6 x 3/8" PPH Type AB (Attaches End Dams)	AS21	100 (AS21-1)	\$5
 #10-24 x 3/8" UCPFH (Attaching SR101 or SR102 Steel Reinforcing)	AS24	100 (AS24-1)	\$19
 Drill Jig for Screw Spline (Required for Series FL600 Storefront)	DJ600	1	\$355
 End Dam for Sill Flashing (Requires Two AS21 Screws)	ED639-1	20 (ED639-2)	\$35
 EPDM Gasket (Standard Gasket for 1/4" Glazing)	NG1	300 FT. (Per Roll)	\$136
 Heavy Glazing Gasket	NG2	500 FT. (Per Roll)	\$342
 3/8" Glazing Gasket	NG3	250 FT. (Per Roll)	\$132

ACCESSORIES			
PART DESCRIPTION	PART NO.	QTY	PRICE PER BOX
 4" Long EPDM Setting Block for 1" Glass (Exterior Glazing - Two Per Lite)	SB3	100 (SB3-1)	\$97
 Water Diverter (Horizontal - Two Per Lite)	WD300-1	50 (WD300-2)	\$62
 Vinyl Gasket (Standard Weathering Gasket for FL210 and CS118 / CS119)	VG10	250 FT. (VG10-1) (Per Roll)	\$49
 Joint Sealant Tape (1/8" x 1/2" for Sealing Horizontal to Vertical Member Connections)	SM5601	30 FT. (Per Roll)	\$37
 Weathering for D200	WP200	500 FT. (Per Roll)	\$97
 Steel Bracket for Muntin Assembly to Door Stile	TH401	50 (TH401-2)	\$93
 #8 x 3/4" POH TEK Screw	AS7	100 (AS7-1)	\$23

Page Left Intentionally Blank

Section C
CURTAIN WALLS
Table of Contents

PW251 Curtain Wall System..... C1

Page Left Intentionally Blank







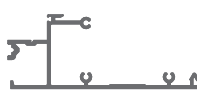
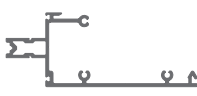

Section C1
Table of Contents

PW251
PANELIZED CURTAIN WALL

2½" x 7"

	<i>Page</i>
Standard Framing Extrusions.....	1
Corner Framing Extrusions	2
Optional Framing Extrusions	3
Door Framing Extrusions	3
Accessories.....	4
Steel Reinforcing.....	5
Glazing Infill Charts and Setting Block/Setting Chair Charts	5

Page Left Intentionally Blank







STANDARD FRAMING EXTRUSIONS									
PART DESCRIPTION	PART NO.	PART LENGTH	PCS. PER BOX	FINISH CODE/STOCK LENGTH LIST PRICE					
				#10 CLEAR	#20 BRONZE	#81 WHITE	#2604 POWDER	#2605 POWDER	
 Head/Sill	PW152	24'	3	Mill-00 \$192	N/A	N/A	N/A	N/A	
 Intermediate Horizontal	PW155	24'	3	\$255	\$271	\$271	\$260	\$280	
 Head/Horizontal/Sill Trim	PW203	24'	4	\$133	\$144	\$144	\$180	\$205	
 Wall Jamb	PW153	24'	3	\$265	\$284	\$284	\$291	\$317	
 Vertical Mullion	PW150	24'	3	\$266	\$283	\$283	\$298	\$324	
 Vertical Mullion Butt Glazed	PW151	24'	3	\$219	\$234	\$234	\$259	\$285	
 Vertical Mullion Filler	PW202	24'	12	\$91	\$98	\$98	\$125	\$143	
 Pocket Filler for PW150 (For use at Jamb)	PW213	24'	8	\$35	\$39	\$39	\$80	\$96	
 Pre-Punched Pressure Bar w/ Spacer Gasket	PW204-1	24'	12	Mill-00 \$77	N/A	N/A	N/A	N/A	
 Vertical/Horizontal Face Cover	PW205	24'	12	\$42	\$47	\$47	\$78	\$92	

Note: Add Finish Code to the Part Number when ordering (Ex: **PW150-10** for Clear Anodized Finish)





PW251·2½" x 7"



Screw-Spline Curtain Wall



CORNER FRAMING EXTRUSIONS								
PART DESCRIPTION	PART NO.	PART LENGTH	PCS. PER BOX	FINISH CODE/STOCK LENGTH LIST PRICE				
				#10 CLEAR	#20 BRONZE	#81 WHITE	#2604 POWDER	#2605 POWDER
 90° Outside Corner	PW156	24'	4	Mill-00	N/A	N/A	N/A	N/A
				\$117				
 90° Outside Corner Pre-punched Pressure Bar with Spacer Gasket	PW157-1	24'	4	Mill-00	N/A	N/A	N/A	N/A
				\$165				
 Glazing Face Cover 90° Outside Corner (2 required)	PW158	24'	12	\$60	\$66	\$66	\$108	\$125
 Female Half 90° Outside Corner	PW208	24'	4	\$167	\$179	\$179	\$213	\$236
 Male Half 90° Outside Corner	PW209	24'	4	\$177	\$189	\$189	\$220	\$243
 Interior 90° Corner Trim	PW210	24'	4	\$88	\$95	\$95	\$140	\$161
 90° Corner Splice	PW211	24'	4	Mill-00	N/A	N/A	N/A	N/A
				\$118				

Note: Add Finish Code to the Part Number when ordering (Ex: **PW150-10** for Clear Anodized Finish)



DOOR FRAMING EXTRUSIONS								
PART DESCRIPTION	PART NO.	PART LENGTH	PCS. PER BOX	FINISH CODE/STOCK LENGTH LIST PRICE				
				#10 CLEAR	#20 BRONZE	#81 WHITE	#2604 POWDER	#2605 POWDER
 Header / Transom Bar for Surface Mount Closer	FL207	24'	4	\$227	\$238	\$238	\$328	\$363
 Frame Jamb	PW214	24'	4	\$137	\$149	\$149	\$185	\$208
 COC Transom Bar / Header	FL212	24'	4	\$177	\$184	\$184	\$309	\$349
 Snap-in Door Stop (Use with FL207)	DS200	24'	3	\$31	\$34	\$34	\$72	\$86
 Screw Applied Door Stop (Use with FL212)	DS202	24'	4	\$78	\$84	\$84	\$137	\$157







OPTIONAL FRAMING EXTRUSIONS								
PART DESCRIPTION	PART NO.	PART LENGTH	PCS. PER BOX	FINISH CODE/STOCK LENGTH LIST PRICE				
				#10 CLEAR	#20 BRONZE	#81 WHITE	#2604 POWDER	#2605 POWDER
 ¼" Glazing Adapter	PW212	24'	4	\$27	\$31	\$31	\$78	\$93
 ¼" Transition Glazing Adapter for Butt - Glazed Mullion	PW215	24'	4	Mill-00	N/A	N/A	N/A	N/A
				\$55				
 Splice Sleeve / or Mullion Reinforcement	PW207	24'	3	\$189	N/A	N/A	N/A	N/A

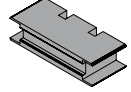
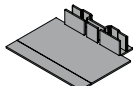
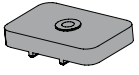

Note: Add Finish Code to the Part Number when ordering (Ex: **PW150-10** for Clear Anodized Finish)

PW251·2½" x 7"

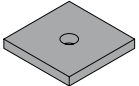
Screw-Spline Curtain Wall

ACCESSORIES			
PART DESCRIPTION	PART NO.	QUANTITY	PRICE PER BOX
 Spline Screw #14 x 1 HHSTS	AS16	100 (AS16-1)	\$12
 #6 x 3/8" PPH Type AB (Attaches End Dams)	AS21	100 (AS21-1)	\$5
 #12 x 3/4" HWH #3 Zinc Plated Self Drilling	AS25	100 (AS25-1)	\$8
 12 x 1 1/4" HWH #3 Zinc Plated Self Drilling (Pressure Bar Screws)	AS32	200 (AS32-1)	\$18
 12 x 1" FHP Self Drilling	AS35	100 (AS35-1)	\$14
 3 x 1/4 x 20 Hex Head Bolt SS	AS53	25 (AS53-1)	\$21
 1/4 Flat Washer SS	AS54	50 (AS54-1)	\$8
 1/4 x 20 Lock Nut SS	AS55	25 (AS55-1)	\$9
 Interior / Exterior Glazing Gasket at Glass	NG10	250 FT. (Per Roll)	\$129
 Exterior Perimeter Gasket	NG11	500 FT. (Per Roll)	\$261
 Butt Glaze Spacer Gasket	NG14	500 FT. (Per Roll)	\$204

ACCESSORIES			
PART DESCRIPTION	PART NO.	QUANTITY	PRICE PER BOX
 4" Long EPDM Setting Block for 1" Glass	SB251	100 (SB251-1)	\$89
 End Dam	SP203	50 (SP203-1)	\$25
 Butt Glaze Mullion Bridge for 1" Glazing	SP207	50 (SP207-1)	\$27
 Top and Bottom Mullion Cover	SP209	50 (SP209-1)	\$149
 Temporary Glazing Retainer	SP253	50 (SP253-1)	\$52
 Joint Sealant Tape (1/4" x 1/2" for Sealing Horizontal to Vertical Member Connections)	SM5601	30 FT. (Per Roll)	\$37
 1.475 x 1.475 x .180 Zinc Plated Steel Square Nut	AS13	50	\$44
 Weather Stripping	WP200	500 FT. (Per Roll)	\$97

STEEL REINFORCING			
PART DESCRIPTION	PART NO.	QUANTITY LENGTH	PRICE
 1⅞" x 4½" x ¼" with Zinc Chromate Primer Steel Reinforcing	SR150	1	\$329
		12'-0"	
 1⅞" x 4½" x 10 Ga. Steel Reinforcing	SR151	1	\$296
		14'-0"	
 1⅞" x 4⅝" x ¼" with Zinc Chromate Primer Steel Reinforcing	SR504	1	\$292
		10'-0"	

Page Left Intentionally Blank

Section D
IMPACT-RESISTANT ENTRANCES
Table of Contents

Impact-Resistant Entrances..... D1
Adds, Substitutions, and Modifications..... D2

Page Left Intentionally Blank

Section D1 Table of Contents

IMPACT-RESISTANT ENTRANCES

Doors and Frames

Entrance Door Handing Information.....	1
Door Types and Descriptions.....	3
Entrance Door and Numbering Information.....	5
Push/Pull Hardware Options.....	7
Glass Sizes.....	9
Standard Hardware Locations.....	11
Notes and Policies.....	13
Options & Limitation Charts.....	15-19
Impact-Resistant Butt Hung Door and Frames	20-23
Impact-Resistant Butt Hung CVR Panic Doors and Frames	24-27
Impact-Resistant Butt Hung Offset Arm Assembly Doors and Frames	28-31
Impact-Resistant Butt Hung CVR Panic Offset Arm Assembly Doors and Frames	32-35

Page Left Intentionally Blank

Commercial aluminum storefront and entrance doors are primarily designed for:

1. Exterior applications
2. To swing or open out
3. In the case of double acting doors, to swing in and out

Because of the design, and due to building codes and life safety laws prohibiting such, single acting doors may never swing inward when installed in an exterior application. However, when used for interior applications (Example: Interior office doors), unless prevented by a particular building code, doors may swing in, or open to the interior.

HAND: All single acting swing doors are handed. The hand of a single acting swing door indicates which side it is hinged on (or will swing from) and the direction in which it is to swing. When determining the hand of a door, it should be viewed from the exterior. It will either be hinged on its left side, or hinged on its right side, and (for exterior applications) will always swing out. For interior applications, it may swing in.

The “hand” of a door is designated as follows.

For **Exterior applications** (as viewed from the exterior):

1. HL SO Hinge Left Swing Out = RH (Right Hand Door)
2. HR SO Hinge Right Swing Out = LH (Left Hand Door)

For **Interior applications** (as viewed from the exterior):

1. HL SO Hinge Left Swing Out = RH (Right Hand Door)
2. HR SI Hinge Right Swing In = RH (Right Hand Door)
3. HR SO Hinge Right Swing Out = LH (Left Hand Door)
4. HL SI Hinge Left Swing In = LH (Left Hand Door)

SINGLE ACTING commercial aluminum entrances are designed for exterior applications and to open or “swing” in an outward direction. To determine the “hand” of a single acting entrance, envision placing your back against the hinge side of the opening and extend whichever hand would be appropriate for the direction the door opens.

Only entrances used in interior applications are allowed to swing in an inward direction. The same method described above for determining the “hand” of the door applies

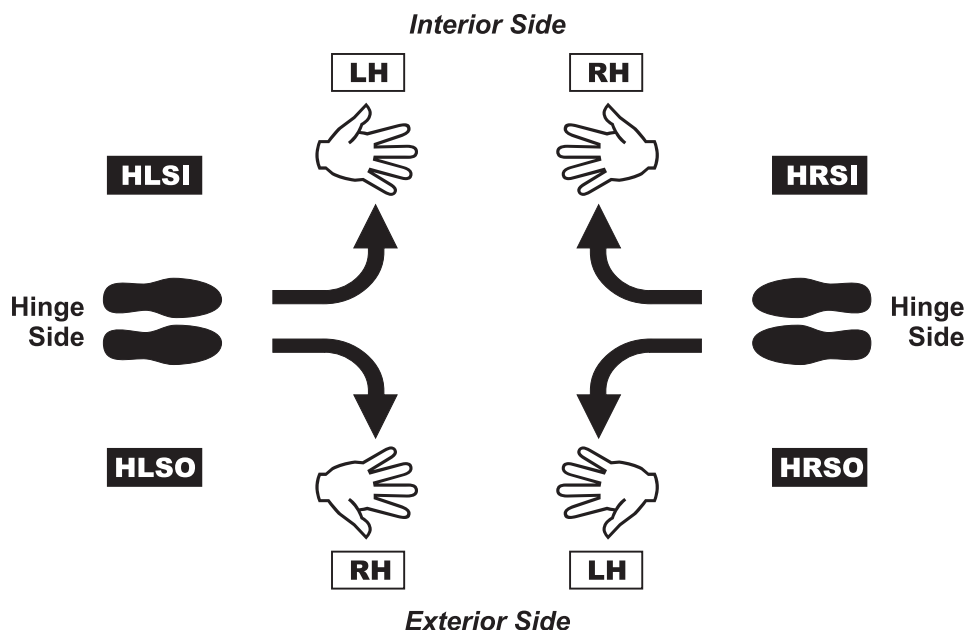

Page Left Intentionally Blank

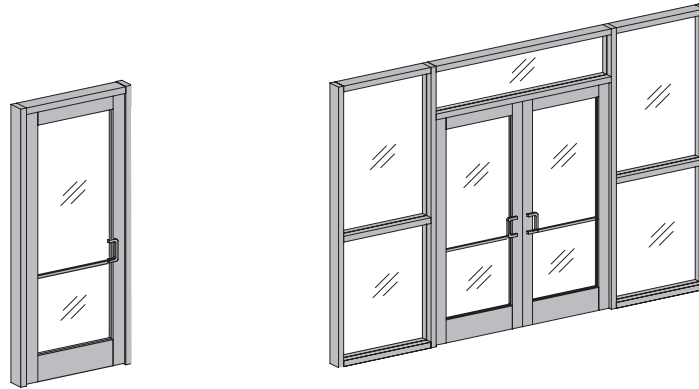

Aluminum Entrance Doors	VERTICAL STILE	TOP RAIL	BOTTOM RAIL	RECOMMENDED LIMITATIONS	TRAFFIC APPLICATION
Series 281 Narrow Stile	2 1/8"	2 1/4"	7 1/2"	3'-0" x 7'-0"	Normal
Series 381 Medium Stile	3 3/4"	4"	7 1/2"	3'-6" x 8'-0"	Moderate
Series 581 Wide Stile	5"	4"	7 1/2"	3'-6" x 8'-0"	Heavy

Note: All Impact doors require 1-1/2 pair butt hinges.

Note: Impact Doors with 1" insulated glazing and a door height > 84", require 2 pair of Butt Hinges.

COMMON DOOR AND FRAME DESCRIPTIONS

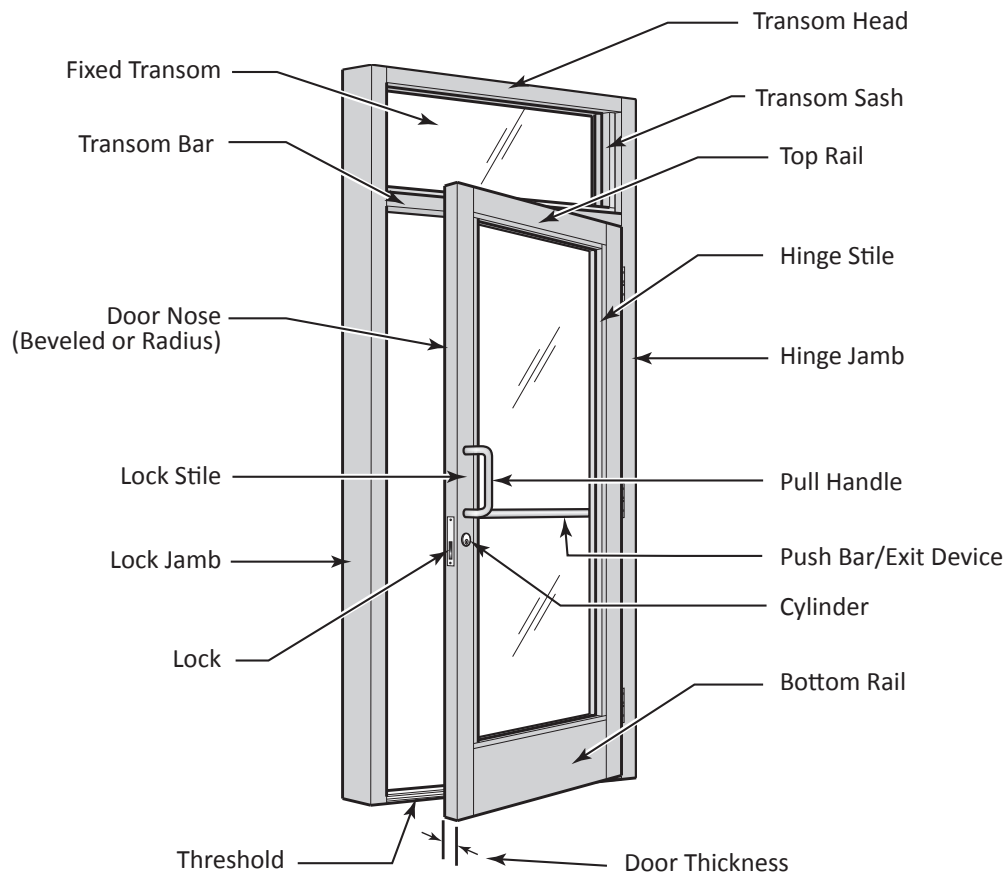

Page Left Intentionally Blank

**DOOR
PART NUMBER
INFORMATION**

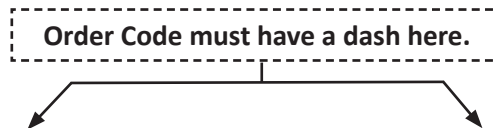

D.O.W. (Inches)	D.O.H. (Inches)	STILE WIDTH	SWING & HINGING	ADDED HARDWARE	FINISH CODE
36 <i>(Specify)</i>	84 <i>(Specify)</i>	<i>(Select)</i>	A <i>(Select)</i>	P <i>(Select)</i>	10 <i>(Select)</i>
DOOR OPENING WIDTH	DOOR OPENING HEIGHT	NARROW = HN MEDIUM = HR WIDE = HS	FROM CHART 1	P = CVR PANIC O = OFFSET ARM	#10 CLEAR #20 BRONZE # 81 White PC #99 2604 PC #89 2605 PC

For example: (3684HR-AP-10)

The above example depicts a 3684 Right Hand Butt Hinge Door with CVR Panic in Clear Anodized Finish

**FRAME
PART NUMBER
INFORMATION**

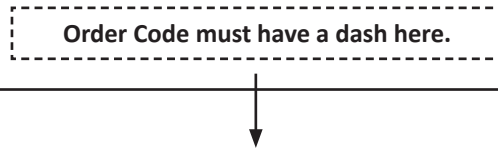

D.O.W. (INCHES)	D.O.H. (Inches)	SWING & HINGING	ADDED HARDWARE	FRAME TYPE	FINISH CODE
36 <i>(Specify)</i>	84 <i>(Specify)</i>	A <i>(Select)</i>	P <i>(Select)</i>	F5 <i>(Select)</i>	10 <i>(Select)</i>
DOOR OPENING WIDTH	DOOR OPENING HEIGHT	FROM CHART 1	P= PANIC O= OFFSET ARM	F5= FRAME FT5= FRAME W/TRANSOM	#10 CLEAR #20 BRONZE # 81 White PC #99 2604 PC #89 2605 PC

For example: (3684-A-F5-10)

The above example depicts a 3684 Right Hand Butt Hinge Frame in Clear Anodized Finish

F5 = 2 1/2" x 5" Frame

FT5 = 2 1/2" x 5" Frame w/ Transom

CHART 1

	BUTT HUNG
RIGHT HAND SINGLE	A
LEFT HAND SINGLE	B
PAIR OF DOORS	J

Page Left Intentionally Blank

Traditional Hardware
Standard on all Doors

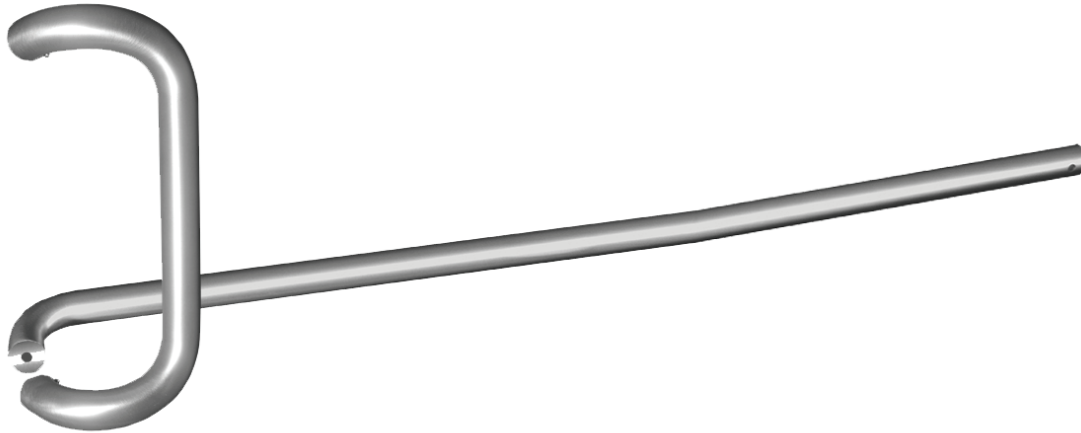

Clear Push/Pull is standard on clear and powder coat doors.
Champagne Push/Pull is standard on bronze doors.

Page Left Intentionally Blank

GLASS SIZES FOR SERIES 281, SERIES 381 AND SERIES 581 IMPACT ENTRANCE DOORS

DOOR OPENING	STILE TYPE	TOP RAIL (PART NUMBER)	TOP RAIL HEIGHT	BOTTOM RAIL (PART NUMBER)	BOTTOM RAIL HEIGHT	STILE WIDTH	GLASS SIZE
3684 or 7284	NS281	D101	2 ¼"	D102	4"	2 ⅝"	31 ⅛" x 76 ½"
3684 or 7284	NS281	D102	4"	D102	4"	2 ⅝"	31 ⅛" x 74 ¾"
3684 or 7284	NS281	D101	2 ¼"	D108	7 ½"	2 ⅝"	31 ⅛" x 73"
3684 or 7284	NS281	D101	4"	D109	9 ½"	2 ⅝"	31 ⅛" x 71"
3684 or 7284	MS381	D102	4"	D108	7 ½"	3 ¾"	27 ⅞" x 71 ¼"
3684 or 7284	WS581	D102	4"	D108	7 ½"	5"	25 ⅜" x 71 ¼"
3684 or 7284	MS381	D102	4"	D109	9 ½"	3 ¾"	27 ⅞" x 69 ¼"
3684 or 7284	WS581	D102	4"	D109	9 ½"	5"	25 ⅜" x 69 ¼"
4284 or 8484	MS381	D102	4"	D108	7 ½"	3 ¾"	33 ⅞" x 71 ¼"
4284 or 8484	WS581	D102	4"	D108	7 ½"	5"	31 ⅜" x 71 ¼"
4284 or 8484	MS381	D102	4"	D109	9 ½"	3 ¾"	33 ⅞" x 69 ¼"
4284 or 8484	WS581	D102	4"	D109	9 ½"	5"	31 ⅜" x 69 ¼"

GLASS WIDTH FORMULAS (inches)

SINGLE or PAIR	FORMULA
Single	NS281= D.O.W. minus 4 ⅞"
Pair	NS281= D.O.W. divided by 2 minus 4 ⅞"
Single	MS381= D.O.W. minus 8 ⅞"
Pair	MS381= D.O.W. divided by 2 minus 8 ⅞"
Single	WS581= D.O.W. minus 10 ⅝"
Pair	WS581= D.O.W. divided by 2 minus 10 ⅝"

Note: D.O.W. = Door Opening Width

GLASS HEIGHT FORMULAS (inches)

STEP #			EXAMPLE	
1)	D.O.W. Door Height dimension specified is:		84"	
2)	Deduct clearance at Door Frame Header:	- ⅛"	(- ⅛")	N/A
3)	Deduct Top Rail dimension:	Select	(4")	Part # = (D102)
4)	Deduct Bottom Rail dimension:	Select	(7 ½")	Part # = (D108)
5)	Deduct clearance between Bottom of Door and Top of Threshold:	- ⅜"	(- ⅜")	N/A
6)	Deduct for height of Threshold:	- ½"	(- ½")	Part # = (TH4)
7)	Deduct for Glass Bite and Setting Block:	- ⅞"	(- ⅞")	N/A
Note: D.O.H. = Door Opening Height		Glass Height	(71 ¼")	

Page Left Intentionally Blank

Butt Hinge

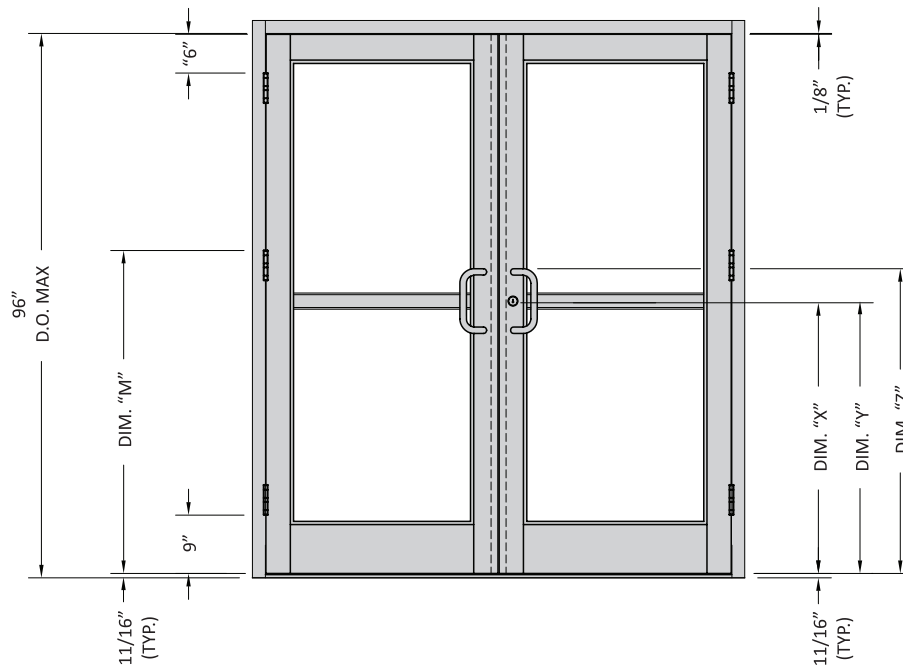

INTERMEDIATE HINGE	
D.O. HEIGHT	DIM. "M"
	BUTT HINGE
84"	45 ¹¹ / ₃₂ "
96"	51 ¹¹ / ₃₂ "

Note: All Impact doors require 1-½ pair butt hinges. Impact doors with 1" glazing and > 84" require 2 pair butt hinges.

HARDWARE LOCATIONS FOR PANIC DOORS				
MANUFACTURER	PANIC DEVICE	☉ DIM "X" OF CYLINDER	☉ DIM "Y" OF PANIC	DIM "Z" TOP OF PULL
FIRST CHOICE	3190 C.V.R.	39 ⁵ / ₃₂ "	41 ³ / ₃₂ "	44 ⁵ / ₃₂ "
FIRST CHOICE	3692 C.V.R.	41 ⁹ / ₁₆ "	40 ⁵ / ₈ "	46 ⁹ / ₁₆ "

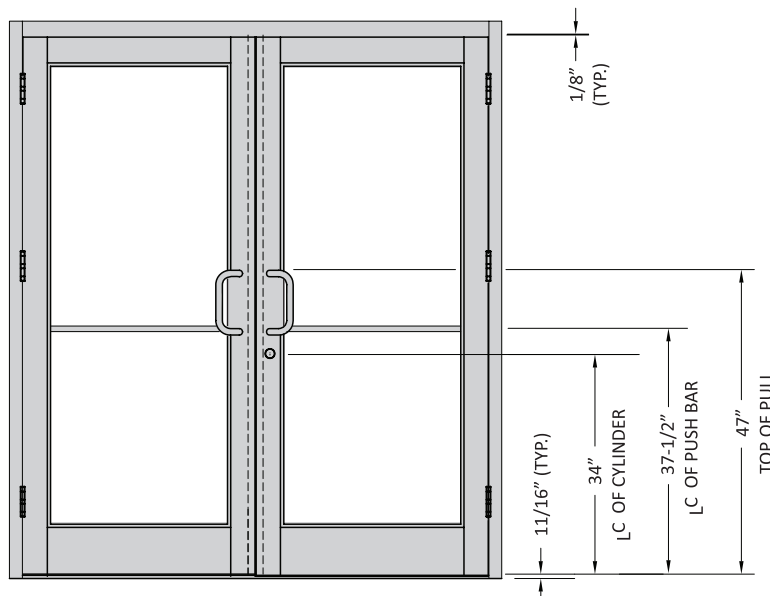

Note: Medium Stile Doors used for Illustration Purposes. Hardware locations are similar for Narrow and Wide Stile Doors

Page Left Intentionally Blank

Impact-Resistant Entrances & Frames

NOTES AND POLICIES COMMON TO EACH PRODUCT

(Unless otherwise specified)

- Series 281 Narrow Stile Door size may not exceed 36" x 84" for single and 72" x 84" for pairs.
- Series 381 Medium Stile Door size may not exceed 42" x 96" for single and 84" x 96" for pairs.
- Series 581 Wide Stile Door size may not exceed 42" x 96" for single and 84" x 96" for pairs.
- Reference Options and Limitations for Series 281, 381 and 581 Impact-Resistant Doors.
- SWING-IN DOORS ARE NOT OFFERED FOR IMPACT APPLICATIONS.
- Doorjamb at wall require FL515 flat filler which is not included in frame package.
- TH4 mill finish threshold is standard on all doors without a panic device.
- TH5B bumper threshold is standard on doors with panic devices.
- Allow additional time for these doors and frames.
- Heavy duty closers are required for impact doors due to extra weight and size.
- Doors were not tested for water infiltration.
- All Impact doors require 1-½ pair butt hinges.
- Impact doors with 1" glazing and > 84" DOH (Door Opening Height) require 2 pair butt hinges.

Page Left Intentionally Blank

High Velocity Hurricane Zone (HVHZ) Applications

Series 281 Narrow Stile Impact-Resistant Entrances (Wet-Glazed)

Qualified System Configuration Chart

Design Pressure P.S.F.	Maximum Door Size		Maximum Glass Size		Qualified Glass Types
	Single	Double	D.L.O. (WxH)	Sq. Ft.	
Series 281 Narrow Stile - Large Missile					
+65/-65	36 x 84	72 x 84	29 $\frac{5}{16}$ " x 71 $\frac{3}{16}$ "	14.7	B

Hurricane Impact-Resistant Products Disclaimer Note

Coral's hurricane impact-resistant products meet a variety of test standards for applications in coastal construction regions satisfying the demands for wind-borne debris hazards and high-velocity winds associated with hurricanes. All of Coral's hurricane impact-resistant products are independent laboratory tested based on a variety of test standards for air infiltration, structural loads, missile impact and air-pressure cycling based on ASTM and/or Florida Building Code. The informational chart above is intended to provide recommended limits in frame heights, glass sizes and design pressures based on product testing. When exceeding conditions listed above it is recommended to consult with licensed structural engineer or contact Coral Architectural Products.

Hardware Applications

Locking and Closer Options		
Active Leaf	DH072 3-Point Lock with DH078 Cylinder and DH079 Thumbturn	
Inactive Leaf	DH176 Steel Tip Flush Bolts (2 each)	
Surface Applied Closer	Heavy Duty ANSI Grade 1 (Required)	
Concealed Overhead Closer	ANSI Grade 1 (Required)	
Hinging Options		
Type	Description	Quantity
Butt Hinges	DH110SS (Stainless Steel) 4 $\frac{1}{2}$ " x 4"	1 $\frac{1}{2}$ Pairs
Continuous Geared Hinge	DH111HD (Heavy Duty)	Full Door Height
Panic Exit Devices Options		
Jackson	2086-HR ANSI Grade 1	Concealed Vertical Rod

Qualified Glass Types

Glass Type	Glass Composition			Interlayer Manufacturer	Glass Identification
	Exterior Lite	Interlayer	Interior Lite		
$\frac{3}{16}$ " Monolithic Glass	$\frac{1}{4}$ " Heat Strengthened Glass	.090 Saflex PVB Interlayer	$\frac{1}{4}$ " Heat Strengthened Glass	Solutia	B

High Velocity Hurricane Zone (HVHZ) Applications

Series 381 Medium Stile Impact-Resistant Entrances (Wet-Glazed)

Qualified System Configuration Chart

Design Pressure P.S.F.	Maximum Door Size		Maximum Glass Size		Qualified Glass Types
	Single	Double	D.L.O. (WxH)	Sq. Ft.	
Series 381 Medium Stile - Large Missile Impact					
+70/-70	42 x 96	84 x 96	32 $\frac{5}{16}$ " x 81 $\frac{1}{16}$ "	18.3	A, B, C, D, IAD, IBD, IDD, IED

Hurricane Impact-Resistant Products Disclaimer Note

Coral's hurricane impact-resistant products meet a variety of test standards for applications in coastal construction regions satisfying the demands for wind-borne debris hazards and high-velocity winds associated with hurricanes. All of Coral's hurricane impact-resistant products are independent laboratory tested based on a variety of test standards for air infiltration, structural loads, missile impact and air-pressure cycling based on ASTM and/or Florida Building Code. The informational chart above is intended to provide recommended limits in frame heights, glass sizes and design pressures based on product testing. When exceeding conditions listed above it is recommended to consult with licensed structural engineer or contact Coral Architectural Products.

Hardware Applications

Locking and Closer Options		
Active Leaf	DH072 3-Point Lock with DH078 Cylinder and DH079 Thumbturn	
Inactive Leaf	DH176 Steel Tip Flush Bolts (2 each)	
Surface Applied Closer	Heavy Duty ANSI Grade 1 (Required)	
Concealed Overhead Closer	ANSI Grade 1 (Required)	
Hinging Options		
Type	Description	Quantity
Butt Hinges	DH110SS (Stainless Steel) 4 $\frac{1}{2}$ " x 4"	1 $\frac{1}{2}$ Pairs
Continuous Geared Hinge	DH111HD (Heavy Duty)	Full Door Height
Panic Exit Devices Options		
First Choice	DH3692 ANSI Grade 1	Concealed Vertical Rod
First Choice	DH3192 ANSI Grade 1	Mid Panel Panic
Jackson	DH2086 ANSI Grade 1	Concealed Vertical Rod

Qualified Glass Types

Glazing Schedule			Glazing Schedule Insulated		
Glass Mark Symbol	Glass Type	Manufacturer	Glass Mark Symbol	Glass Type	Manufacturer
A	.25HS x VS02(Vanceva) .075 x .25HS	Solutia	IAD	3/16" HS x 1/4" ABS x 3/16" HS x VS02(Vanceva) .075 x 1/4" HS	Solutia
B	.25HS x .090 Saflex x .25HS	Solutia	IBD	3/16" HS x 1/4" ABS x 3/16" HS x .090 Saflex x 1/4" HS	Solutia
C	.25HS x .090 Sentry GLAS x .25HS	Kuraray	IDD	3/16" HS x 1/4" ABS x 3/16" HS x .090 Sentry Glas x 1/4" HS	Kuraray
D	.25HS x .090 Butcite x .25HS	Kuraray	IED	3/16" HS x 1/4" ABS x 3/16" HS x .090 Butcite x 1/4" HS	Kuraray

High Velocity Hurricane Zone (HVHZ) Applications

Series 381 Medium Stile Impact-Resistant Entrances (Dry-Glazed)

Qualified System Configuration Chart

Design Pressure P.S.F.	Maximum Door Size		Maximum Glass Size		Qualified Glass Types
	Single	Double	D.L.O. (WxH)	Sq. Ft.	
Series 381 Medium Stile - Large Missile Impact					
+70/-70	36 x 84	72 x 84	26 ⁵ / ₁₆ " x 69 ¹ / ₁₆ "	12.7	D

Hurricane Impact-Resistant Products Disclaimer Note

Coral's hurricane impact-resistant products meet a variety of test standards for applications in coastal construction regions satisfying the demands for wind-borne debris hazards and high-velocity winds associated with hurricanes. All of Coral's hurricane impact-resistant products are independent laboratory tested based on a variety of test standards for air infiltration, structural loads, missile impact and air-pressure cycling based on ASTM and/or Florida Building Code. The informational chart above is intended to provide recommended limits in frame heights, glass sizes and design pressures based on product testing. When exceeding conditions listed above it is recommended to consult with licensed structural engineer or contact Coral Architectural Products.

Hardware Applications

Locking and Closer Options		
Active Leaf	DH072 3-Point Lock with DH078 Cylinder and DH079 Thumbturn	
Inactive Leaf	DH176 Steel Tip Flush Bolts (2 each)	
Surface Applied Closer	Heavy Duty ANSI Grade 1 (Required)	
Concealed Overhead Closer	ANSI Grade 1 (Required)	
Hinging Options		
Type	Description	Quantity
Butt Hinges	DH110SS (Stainless Steel) 4 ¹ / ₂ " x 4"	1 ¹ / ₂ Pairs
Continuous Geared Hinge	DH111HD (Heavy Duty)	Full Door Height
Panic Exit Devices Options		
First Choice	DH3692 ANSI Grade 1	Concealed Vertical Rod
First Choice	DH3192 Midpanel	Concealed Vertical Rod
Jackson	DH2086 ANSI Grade 1	Concealed Vertical Rod

Qualified Glass Types

Glass Type	Glass Composition			Interlayer Manufacturer	Glass Identification
	Exterior Lite	Interlayer	Interior Lite		
⁵ / ₁₆ " Monolithic Glass	¹ / ₄ " Heat Strengthened Glass	.090 SentryGlas	¹ / ₄ " Heat Strengthened Glass	Kuraray	D

High Velocity Hurricane Zone (HVHZ) Applications

Series 581 Wide Stile Impact-Resistant Entrances (Wet-Glazed)

Qualified System Configuration Chart

Design Pressure P.S.F.	Maximum Door Size		Maximum Glass Size		Qualified Glass Types
	Single	Double	D.L.O. (WxH)	Sq. Ft.	
Series 581 Wide Stile - Large Missile Impact					
+70/-70	42 x 96	84 x 96	29 ¹³ / ₁₆ " x 81 ¹ / ₁₆ "	16.9	A, B, C, D, IAD, IBD, IDD, IED

Hurricane Impact-Resistant Products Disclaimer Note

Coral's hurricane impact-resistant products meet a variety of test standards for applications in coastal construction regions satisfying the demands for wind-borne debris hazards and high-velocity winds associated with hurricanes. All of Coral's hurricane impact-resistant products are independent laboratory tested based on a variety of test standards for air infiltration, structural loads, missile impact and air-pressure cycling based on ASTM and/or Florida Building Code. The informational chart above is intended to provide recommended limits in frame heights, glass sizes and design pressures based on product testing. When exceeding conditions listed above it is recommended to consult with licensed structural engineer or contact Coral Architectural Products.

Hardware Applications

Locking and Closer Options		
Active Leaf	DH072 3-Point Lock with DH078 Cylinder and DH079 Thumbturn	
Inactive Leaf	DH176 Steel Tip Flush Bolts (2 each)	
Surface Applied Closer	Heavy Duty ANSI Grade 1 (Required)	
Concealed Overhead Closer	ANSI Grade 1 (Required)	
Hinging Options		
Type	Description	Quantity
Butt Hinges	DH110SS (Stainless Steel) 4½" x 4"	1½ Pairs
Continuous Geared Hinge	DH111HD (Heavy Duty)	Full Door Height
Panic Exit Devices Options		
First Choice	DH3692 ANSI Grade 1	Concealed Vertical Rod
First Choice	DH3192 ANSI Grade 1	Mid Panel Panic
Jackson	DH2086 ANSI Grade 1	Concealed Vertical Rod

Qualified Glass Types

Glazing Schedule			Glazing Schedule Insulated		
Glass Mark Symbol	Glass Type	Manufacturer	Glass Mark Symbol	Glass Type	Manufacturer
A	.25HS x VS02(Vanceva) .075 x .25HS	Solutia	IAD	3/16" HS x 1/4" ABS x 3/16" HS x VS02(Vanceva) .075 x 1/4" HS	Solutia
B	.25HS x .090 Saflex x .25HS	Solutia	IBD	3/16" HS x 1/4" ABS x 3/16" HS x .090 Saflex x 1/4" HS	Solutia
C	.25HS x .090 Sentry GLAS x .25HS	Kuraray	IDD	3/16" HS x 1/4" ABS x 3/16" HS x .090 Sentry Glas x 1/4" HS	Kuraray
D	.25HS x .090 Butcite x .25HS	Kuraray	IED	3/16" HS x 1/4" ABS x 3/16" HS x .090 Butcite x 1/4" HS	Kuraray

High Velocity Hurricane Zone (HVHZ) Applications

Series 581 Wide Stile Impact-Resistant Entrances (Dry-Glazed)

Qualified System Configuration Chart

Design Pressure P.S.F.	Maximum Door Size		Maximum Glass Size		Qualified Glass Types
	Single	Double	D.L.O. (WxH)	Sq. Ft.	
Series 581 Wide Stile - Large Missile Impact					
+70/-70	42 x 96	84 x 96	29 ¹³ / ₁₆ " x 81 ¹ / ₁₆ "	16.9	D

Hurricane Impact-Resistant Products Disclaimer Note

Coral's hurricane impact-resistant products meet a variety of test standards for applications in coastal construction regions satisfying the demands for wind-borne debris hazards and high-velocity winds associated with hurricanes. All of Coral's hurricane impact-resistant products are independent laboratory tested based on a variety of test standards for air infiltration, structural loads, missile impact and air-pressure cycling based on ASTM and/or Florida Building Code. The informational chart above is intended to provide recommended limits in frame heights, glass sizes and design pressures based on product testing. When exceeding conditions listed above it is recommended to consult with licensed structural engineer or contact Coral Architectural Products.

Hardware Applications

Locking and Closer Options		
Active Leaf	DH072 3-Point Lock with DH078 Cylinder and DH079 Thumbturn	
Inactive Leaf	DH176 Steel Tip Flush Bolts (2 each)	
Surface Applied Closer	Heavy Duty ANSI Grade 1 (Required)	
Concealed Overhead Closer	ANSI Grade 1 (Required)	
Hinging Options		
Type	Description	Quantity
Butt Hinges	DH110SS (Stainless Steel) 4 ¹ / ₂ " x 4"	1 ¹ / ₂ Pairs
Continuous Geared Hinge	DH111HD (Heavy Duty)	Full Door Height
Panic Exit Devices Options		
First Choice	DH3692 ANSI Grade 1	Concealed Vertical Rod
First Choice	DH3192 ANSI Grade 1	Mid Panel Panic
Jackson	DH2086 ANSI Grade 1	Concealed Vertical Rod

Qualified Glass Types

Glass Type	Glass Composition			Interlayer Manufacturer	Glass Identification
³ / ₁₆ " Monolithic Glass	¹ / ₄ " Heat Strengthened Glass	.090 SentryGlas	¹ / ₄ " Heat Strengthened Glass	Kuraray	D

Impact Entrances

Butt Hinge

Butt Hinge Door Package Includes

- Traditional 1" rd Pull/Push Hardware
- Glass Stops for 3/4" or 1" Glazing
- 1 1/2 Pair 4 1/2" x 4" SS Butt Hinges
- 3 Pt Lock - Single or Active Leaf
- Top & Bottom Steel Flush Bolts Inactive Leaf
- Keyed Cylinder Exterior
- Thumb Turn Interior
- Door Sweep w/ Weathering

Note: Reference Hardware Section of the Price Catalog for Door Closers and Loose Hardware Items not included in Standard Entrance section.

Note: All Hardware on Powder coat products is furnished in a standard clear finish.



Order Number Example: **3684HR-B** (Size and Series) - (Hand or Pair)

SERIES 281 NARROW STILE						
HAND	DESCRIPTION	FINISH CODE / DOOR PRICE				
		#10 CLEAR	#20 BRONZE	#81 WHITE	#2604 POWDER	#2605 POWDER
RH	3684HN-A	\$740	\$762	\$762	\$868	\$908
LH	3684HN-B	\$740	\$762	\$762	\$868	\$908
PAIR	7284HN-J	\$1,427	\$1,485	\$1,485	\$1,662	\$1,737



SERIES 381 MEDIUM STILE						
HAND	DESCRIPTION	FINISH CODE / DOOR PRICE				
		#10 CLEAR	#20 BRONZE	#81 WHITE	#2604 POWDER	#2605 POWDER
RH	3684HR-A	\$772	\$802	\$802	\$914	\$958
LH	3684HR-B	\$772	\$802	\$802	\$914	\$958
RH	4284HR-A	\$803	\$826	\$826	\$953	\$1000
LH	4284HR-B	\$803	\$826	\$826	\$953	\$1000
PAIR	7284HR-J	\$1,494	\$1,554	\$1,554	\$1,767	\$1,853



SERIES 581 WIDE STILE						
HAND	DESCRIPTION	FINISH CODE / DOOR PRICE				
		#10 CLEAR	#20 BRONZE	#81 WHITE	#2604 POWDER	#2605 POWDER
RH	3684HS-A	\$794	\$824	\$824	\$947	\$995
LH	3684HS-B	\$794	\$824	\$824	\$947	\$995
RH	4284HS-A	\$825	\$848	\$848	\$987	\$1,038
LH	4284HS-B	\$825	\$848	\$848	\$987	\$1,038
PAIR	7284HS-J	\$1,537	\$1,598	\$1,598	\$1,834	\$1,949

Note: Add "DM141" to substitute Glass Stops used for 1" Insulated Glass.

Butt Hinge Frame Package Includes

- 2½" x 5" Open Back Frame
- Snap-in DS501 Door Stop w/pile
- ½" x 4" Threshold – Mill Finish
- Threshold Clips
- Prep for 1½ Pair 4½" x 4" SS Butt Hinges
- Prep for 3 Pt Lock
- Prep for Top & Bottom Flush Bolts (pair)
- Transom Frames include FL517(Sash) and FL518(Stop) for Wet Glaze
- Frame assembly fastener package

Note: All Hardware on Powder coat products is furnished in a standard clear finish.

Note: Standard Frame Height for Transom Frames = 10'.

Order Number Example: 3684-B-FT5 (Size) - (Hand or Pair) - (Type)

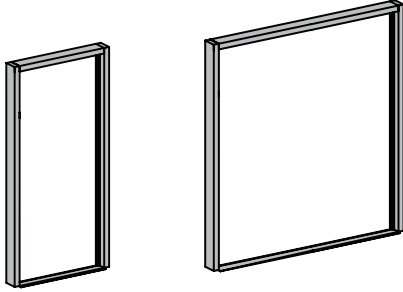

FL500 DOOR FRAME (Non-Transom)						
HAND	DESCRIPTION	FINISH CODE / FRAME PRICE				
		#10 CLEAR	#20 BRONZE	#81 WHITE	#2604 POWDER	#2605 POWDER
RH	3684-A-F5	\$402	\$416	\$416	\$478	\$505
LH	3684-B-F5	\$402	\$416	\$416	\$478	\$505
RH	4284-A-F5	\$415	\$429	\$429	\$494	\$521
LH	4284-B-F5	\$415	\$429	\$429	\$494	\$521
PAIR	7284-J-F5	\$488	\$504	\$504	\$582	\$615

Note: Maximum Frame Height = 120"

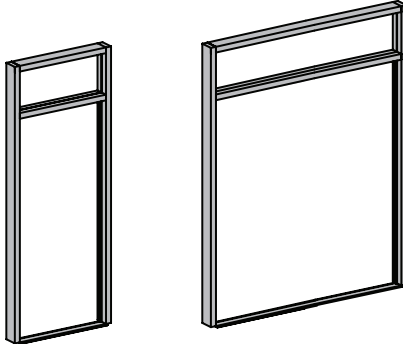

FL500 DOOR FRAME WITH TRANSOM						
HAND	DESCRIPTION	FINISH CODE / FRAME PRICE				
		#10 CLEAR	#20 BRONZE	#81 WHITE	#2604 POWDER	#2605 POWDER
RH	3684-A-FT5	\$604	\$626	\$626	\$755	\$803
LH	3684-B-FT5	\$604	\$626	\$626	\$755	\$803
RH	4284-A-FT5	\$619	\$642	\$642	\$776	\$826
LH	4284-B-FT5	\$619	\$642	\$642	\$776	\$826
PAIR	7284-J-FT5	\$716	\$742	\$742	\$902	\$961

Note: All FL581 Doorframes requiring sidelites are interchangeable with Series FL550 Framing System by using FL555 Snap-In Filler.

Impact Entrances Butt Hinge

Butt Hinge – Door Package Includes

- Traditional 1" rd Pull/Push Hardware
- Glass Stops for ¾" or 1" Glazing
- 1½ Pair 4½" x 4" SS Butt Hinges
- 3 Pt Lock - Single or Active Leaf
- Top & Bottom Steel Flush Bolts Inactive Leaf
- Keyed Cylinder Exterior
- Thumb Turn Interior
- Door Sweep w/ Weathering

Note: Reference Hardware Section of the Price Catalog for Door Closers and Loose Hardware Items not included in Standard Entrance section.

Note: All Hardware on Powder coat products is furnished in a standard clear finish.

Note: 2 pair of Butt Hinges required with 1" glazing.



Order Number Example: **3696HR-A** (Size and Series) - (Hand or Pair)

SERIES 381 MEDIUM STILE						
HAND	DESCRIPTION	FINISH CODE / DOOR PRICE				
		#10 CLEAR	#20 BRONZE	#81 WHITE	#2604 POWDER	#2605 POWDER
RH	3696HR-A	\$798	\$829	\$829	\$955	\$1004
LH	3696HR-B	\$798	\$829	\$829	\$955	\$1004
RH	4296HR-A	\$832	\$856	\$856	\$997	\$1,049
LH	4296HR-B	\$832	\$856	\$856	\$997	\$1,049
PAIR	7296HR-J	\$1,551	\$1,613	\$1,613	\$1,853	\$1,949



Order Number Example: **3696HS-A** (Size and Series) - (Hand or Pair)

SERIES 581 WIDE STILE						
HAND	DESCRIPTION	FINISH CODE / DOOR PRICE				
		#10 CLEAR	#20 BRONZE	#81 WHITE	#2604 POWDER	#2605 POWDER
RH	3696HS-A	\$823	\$855	\$855	\$995	\$1,048
LH	3696HS-B	\$823	\$855	\$855	\$995	\$1,048
RH	4296HS-A	\$857	\$883	\$883	\$1,037	\$1,093
LH	4296HS-B	\$857	\$883	\$883	\$1,037	\$1,093
PAIR	7296HS-J	\$1,601	\$1,665	\$1,665	\$1,933	\$2,037

Note: Add "DM141" to substitute Glass Stops used for 1" Insulated Glass.

Butt Hinge Frame Package Includes

- 2½" x 5" n Back Frame
- Snap-in DS501 Door Stop w/pile
- ½" x 4" Threshold – Mill Finish
- Threshold Clips
- Prep for 1½ Pair 4½" x 4" SS Butt Hinges
- Prep for 3 Pt Lock
- Prep for Top & Bottom Flush Bolts (pair)
- Transom Frames include FL517 (Sash) and FL518(Stop) for Wet Glaze
- Frame assembly fastener package

Note: All Hardware on Powder coat products is furnished in a standard clear finish.

Note: Standard Frame Height for Transom Frames = 10'.

Order Number Example: **3696-B-FT5** (Size) - (Hand or Pair) - (Type)

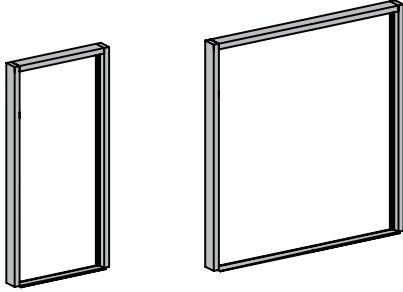

FL500 DOOR FRAME (Non-Transom)						
HAND	DESCRIPTION	FINISH CODE / FRAME PRICE				
		#10 CLEAR	#20 BRONZE	#81 WHITE	#2604 POWDER	#2605 POWDER
RH	3696-A-F5	\$427	\$442	\$442	\$511	\$541
LH	3696-B-F5	\$427	\$442	\$442	\$511	\$541
RH	4296-A-F5	\$439	\$455	\$455	\$527	\$558
LH	4296-B-F5	\$439	\$455	\$455	\$527	\$558
PAIR	7296-J-F5	\$512	\$530	\$530	\$616	\$651

Note: Maximum Frame Height = 120"

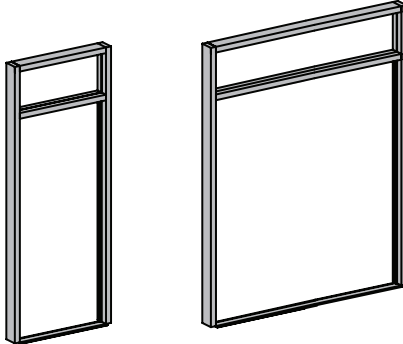

FL500 DOOR FRAME WITH TRANSOM						
HAND	DESCRIPTION	FINISH CODE / FRAME PRICE				
		#10 CLEAR	#20 BRONZE	#81 WHITE	#2604 POWDER	#2605 POWDER
RH	3696-A-FT5	\$601	\$623	\$623	\$738	\$783
LH	3696-B-FT5	\$601	\$623	\$623	\$738	\$783
RH	4296-A-FT5	\$616	\$638	\$638	\$759	\$805
LH	4296-B-FT5	\$616	\$638	\$638	\$759	\$805
PAIR	7296-J-FT5	\$713	\$740	\$740	\$885	\$941

Note: All FL581 Door frames requiring sidelites are interchangeable with Series FL550 Framing System by using FL555 Snap-In Filler.

Impact Entrances

Butt Hinge/Panic

Butt Hinge CVR Panic Door Package Includes

- Traditional 1" rd rd Panic Pull
- Glass Stops for 3/8" Glazing
- 1 1/2 Pair 4 1/2" x 4" SS Butt Hinges
- DH3692 CVR Touch Bar Panic(s)
- Keyed Cylinder Exterior
- Door Sweep w/ Weathering

Note: Reference Hardware Section of the Price Catalog for Door Closers and Loose Hardware Items not included in Standard Entrance section.

Note: All Hardware on Powder coat products is furnished in a standard clear finish.



Order Number Example: **3684HR-BP** (Size and Series) - (Hand or Pair)

SERIES 281 NARROW STILE						
HAND	DESCRIPTION	FINISH CODE / DOOR PRICE				
		#10 CLEAR	#20 BRONZE	#81 WHITE	#2604 POWDER	#2605 POWDER
RH	3684HN-AP	\$1,486	\$1,539	\$1,539	\$1,615	\$1,655
LH	3684HN-BP	\$1,486	\$1,539	\$1,539	\$1,615	\$1,655
PAIR	7284HN-JP	\$2,973	\$3,080	\$3,080	\$3,207	\$3,283



SERIES 381 MEDIUM STILE						
HAND	DESCRIPTION	FINISH CODE / DOOR PRICE				
		#10 CLEAR	#20 BRONZE	#81 WHITE	#2604 POWDER	#2605 POWDER
RH	3684HR-AP	\$1,020	\$1,041	\$1,041	\$1,161	\$1,205
LH	3684HR-BP	\$1,020	\$1,041	\$1,041	\$1,161	\$1,205
RH	4284HR-AP	\$1,038	\$1,060	\$1,060	\$1,188	\$1,235
LH	4284HR-BP	\$1,038	\$1,060	\$1,060	\$1,188	\$1,235
PAIR	7284HR-JP	\$2,064	\$2,109	\$2,109	\$2,336	\$2,423



SERIES 581 WIDE STILE						
HAND	DESCRIPTION	FINISH CODE / DOOR PRICE				
		#10 CLEAR	#20 BRONZE	#81 WHITE	#2604 POWDER	#2605 POWDER
RH	3684HS-AP	\$1,041	\$1,063	\$1,063	\$1,194	\$1,242
LH	3684HS-BP	\$1,041	\$1,063	\$1,063	\$1,194	\$1,242
RH	4284HS-AP	\$1,060	\$1,082	\$1,082	\$1,222	\$1,273
LH	4284HS-BP	\$1,060	\$1,082	\$1,082	\$1,222	\$1,273
PAIR	7284HS-JP	\$2,106	\$2,152	\$2,152	\$2,404	\$2,497

Note: Add "DM141" to substitute Glass Stops used for 1" Insulated Glass.

Butt Hinge CVR Panic Frame Package Includes

- 2½" x 5" n Back Frame
- Snap-in DS501 Door Stop w/pile
- ½" x 5" Bumper Threshold – Mill Finish
- Threshold Clips
- Prep for 1½ Pair 4½" x 4" SS Butt Hinges
- Prep for DH3692 CVR Panic(s)
- Transom Frames include FL517(Sash) and FL518(Stop) for Wet Glaze
- Frame assembly fastener package

Note: All Hardware on Powder coat products is furnished in a standard clear finish.

Note: Standard Frame Height for Transom Frames = 10'.

Order Number Example: **3684-BP-FT5** (Size) - (Hand or Pair) - (Type)

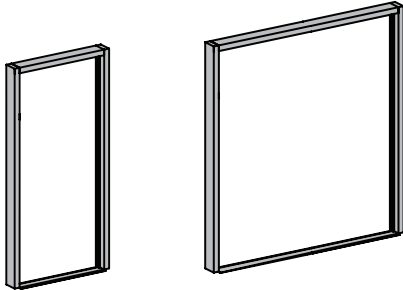

FL500 DOOR FRAME (Non-Transom)						
HAND	DESCRIPTION	FINISH CODE / FRAME PRICE				
		#10 CLEAR	#20 BRONZE	#81 WHITE	#2604 POWDER	#2605 POWDER
RH	3684-AP-F5	\$409	\$423	\$423	\$485	\$512
LH	3684-BP-F5	\$409	\$423	\$423	\$485	\$512
RH	4284-AP-F5	\$415	\$430	\$430	\$495	\$522
LH	4284-BP-F5	\$415	\$430	\$430	\$495	\$522
PAIR	7284-JP-F5	\$494	\$511	\$511	\$589	\$621

Note: Maximum Frame Height = 120"

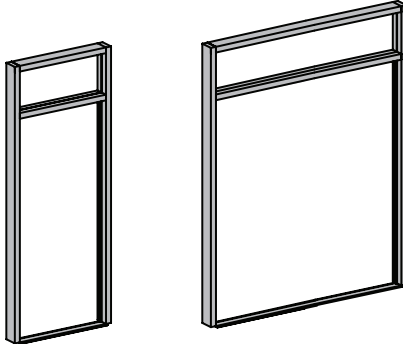

FL500 DOOR FRAME WITH TRANSOM						
HAND	DESCRIPTION	FINISH CODE / FRAME PRICE				
		#10 CLEAR	#20 BRONZE	#81 WHITE	#2604 POWDER	#2605 POWDER
RH	3684-AP-FT5	\$611	\$633	\$633	\$761	\$809
LH	3684-BP-FT5	\$611	\$633	\$633	\$761	\$809
RH	4284-AP-FT5	\$626	\$649	\$649	\$782	\$832
LH	4284-BP-FT5	\$626	\$649	\$649	\$782	\$832
PAIR	7284-JP-FT5	\$723	\$750	\$750	\$909	\$968

Note: All FL581 Doorframes requiring sidelites are interchangeable with Series FL550 Framing System by using FL555 Snap-In Filler.

Impact Entrances

Butt Hinge/Panic

Butt Hinge CVR Panic Door Package Includes

- Traditional 1" round Panic Pull
- Glass Stops for 3/8" or 1" Glazing
- 1 1/2 Pair 4 1/2" x 4" SS Butt Hinges
- DH3692 CVR Touch Bar Panic(s)
- Keyed Cylinder Exterior
- Door Sweep w/ Weathering

Note: Reference Hardware Section of the Price Catalog for Door Closers and Loose Hardware Items not included in Standard Entrance section.

Note: All Hardware on Powder coat products is furnished in a standard clear finish.

Note: 2 pair of Butt Hinges required with 1" glazing.

Order Number Example: **3696HR-AP** (Size and Series) - (Hand or Pair)



SERIES 381 MEDIUM STILE						
HAND	DESCRIPTION	FINISH CODE / DOOR PRICE				
		#10 CLEAR	#20 BRONZE	#81 WHITE	#2604 POWDER	#2605 POWDER
RH	3696HR-AP	\$1,045	\$1,069	\$1,069	\$1,202	\$1,251
LH	3696HR-BP	\$1,045	\$1,069	\$1,069	\$1,202	\$1,251
RH	4296HR-AP	\$1,067	\$1,090	\$1,090	\$1,232	\$1,284
LH	4296HR-BP	\$1,067	\$1,090	\$1,090	\$1,232	\$1,284
PAIR	7296HR-JP	\$2,118	\$2,166	\$2,166	\$2,420	\$2,516

Order Number Example: **3696HS-AP** (Size and Series) - (Hand or Pair)



SERIES 581 WIDE STILE						
HAND	DESCRIPTION	FINISH CODE / DOOR PRICE				
		#10 CLEAR	#20 BRONZE	#81 WHITE	#2604 POWDER	#2605 POWDER
RH	3696HS-AP	\$1,070	\$1,094	\$1,094	\$1,242	\$1,295
LH	3696HS-BP	\$1,070	\$1,094	\$1,094	\$1,242	\$1,295
RH	4296HS-AP	\$1,093	\$1,116	\$1,116	\$1,272	\$1,328
LH	4296HS-BP	\$1,093	\$1,116	\$1,116	\$1,272	\$1,328
PAIR	7296HS-JP	\$2,169	\$2,218	\$2,218	\$2,500	\$2,604

Note: Add "DM141" to substitute Glass Stops used for 1" Insulated Glass.

Butt Hinge CVR Panic Frame Package Includes

- 2½" x 5" Open Back Frame
- Snap-in DS501 Door Stop w/pile
- ½" x 5" Bumper Threshold – Mill Finish
- Threshold Clips
- Prep for 1½ Pair 4½" x 4" SS Butt Hinges
- Prep for DH3692 CVR Panic(s)
- Transom Frames include FL517(Sash) and FL518(Stop) for Wet Glaze
- Frame assembly fastener package

*Note: All Hardware on Powder coat products is furnished in a standard clear finish.
Note: Standard Frame Height for Transom Frames = 10'.*

Order Number Example: **3696-BP-FT5** (Size) - (Hand or Pair) - (Type)

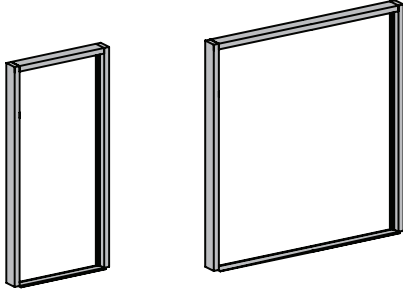

FL500 DOOR FRAME (Non-Transom)						
HAND	DESCRIPTION	FINISH CODE / FRAME PRICE				
		#10 CLEAR	#20 BRONZE	#81 WHITE	#2604 POWDER	#2605 POWDER
RH	3696-AP-F5	\$433	\$449	\$449	\$518	\$548
LH	3696-BP-F5	\$433	\$449	\$449	\$518	\$548
RH	4296-AP-F5	\$446	\$462	\$462	\$534	\$564
LH	4296-BP-F5	\$446	\$462	\$462	\$534	\$564
PAIR	7296-JP-F5	\$519	\$537	\$537	\$623	\$658

Note: Maximum Frame Height = 120"

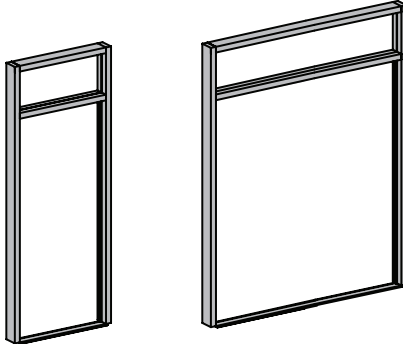

FL500 DOOR FRAME WITH TRANSOM						
HAND	DESCRIPTION	FINISH CODE / FRAME PRICE				
		#10 CLEAR	#20 BRONZE	#81 WHITE	#2604 POWDER	#2605 POWDER
RH	3696-AP-FT5	\$608	\$629	\$629	\$745	\$790
LH	3696-BP-FT5	\$608	\$629	\$629	\$745	\$790
RH	4296-AP-FT5	\$623	\$645	\$645	\$765	\$812
LH	4296-BP-FT5	\$623	\$645	\$645	\$765	\$812
PAIR	7296-JP-FT5	\$720	\$746	\$746	\$892	\$948

Note: All FL581 Doorframes requiring sidelites are interchangeable with Series FL550 Framing System by using FL555 Snap-In Filler.

Impact Entrances

Butt Hinge/Offset Arm

Butt Hinge – Offset Arm Door Package Includes

- Traditional 1" rd Pull/Push Hardware
- Glass Stops for 5/8" 1" Glazing
- 1½ Pair 4½" x 4" SS Butt Hinges
- Slide Channel installed with Offset Arm
- 3 Pt Lock - Single or Active Leaf
- Top & Bottom Steel Flush Bolts Inactive Leaf
- Keyed Cylinder Exterior
- Thumb Turn Interior
- Door Sweep w/ Weathering

Note: Reference Hardware Section of the Price Catalog for Door Closers and Loose Hardware Items not included in Standard Entrance section.

Note: All Hardware on Powder coat products is furnished in a standard clear finish.



Order Number Example: 3684HR-BO (Size and Series) - (Hand or Pair)

SERIES 281 NARROW STILE						
HAND	DESCRIPTION	FINISH CODE / DOOR PRICE				
		#10 CLEAR	#20 BRONZE	#81 WHITE	#2604 POWDER	#2605 POWDER
RH	3684HN-AO	\$873	\$901	\$901	\$1,004	\$1,045
LH	3684HN-BO	\$873	\$901	\$901	\$1,004	\$1,045
PAIR	7284HN-JO	\$1,694	\$1,753	\$1,753	\$1,934	\$2,011



SERIES 381 MEDIUM STILE						
HAND	DESCRIPTION	FINISH CODE / DOOR PRICE				
		#10 CLEAR	#20 BRONZE	#81 WHITE	#2604 POWDER	#2605 POWDER
RH	3684HR-AO	\$898	\$928	\$928	\$1,040	\$1,084
LH	3684HR-BO	\$898	\$928	\$928	\$1,040	\$1,084
RH	4284HR-AO	\$929	\$952	\$952	\$1,079	\$1,126
LH	4284HR-BO	\$929	\$952	\$952	\$1,079	\$1,126
PAIR	7284HR-JO	\$1,746	\$1,806	\$1,806	\$2,019	\$2,105



SERIES 581 WIDE STILE						
HAND	DESCRIPTION	FINISH CODE / DOOR PRICE				
		#10 CLEAR	#20 BRONZE	#81 WHITE	#2604 POWDER	#2605 POWDER
RH	3684HS-AO	\$920	\$949	\$949	\$1,073	\$1,121
LH	3684HS-BO	\$920	\$949	\$949	\$1,073	\$1,121
RH	4284HS-AO	\$951	\$974	\$974	\$1,113	\$1,164
LH	4284HS-BO	\$951	\$974	\$974	\$1,113	\$1,164
PAIR	7284HS-JO	\$1,789	\$1,850	\$1,850	\$2,086	\$2,180

Note: Add "DM141" to substitute Glass Stops used for 1" Insulated Glass.

Butt Hinge - Offset Arm Frame Package Includes

- 2½" x 5" Open Back Frame
- Snap-in DS501 Door Stop w/pile
- Applied DS202 Header Door stop
- ½" x 4" Threshold – Mill Finish
- Threshold Clips
- Prep for 1½ Pair 4½" x 4" SS Butt Hinges
- Prep for 3 Pt Lock
- Prep for Top & Bottom Flush Bolts (pair)
- Prep for COC
- Transom Frames include FL517(Sash) and FL518 (Stop) for Wet Glaze
- Frame assembly fastener package

Note: All Hardware on Powder coat products is furnished in a standard clear finish.

Note: Standard Frame Height for Transom Frames = 10'.

Order Number Example: **3684-BO-FT5** (Size) - (Hand or Pair) - (Type)

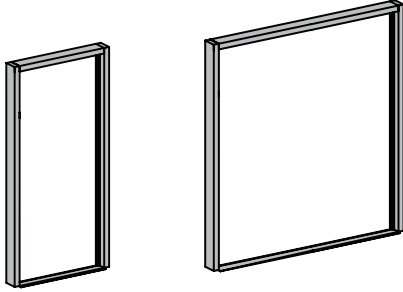

FL500 DOOR FRAME (Non-Transom)						
HAND	DESCRIPTION	FINISH CODE / FRAME PRICE				
		#10 CLEAR	#20 BRONZE	#81 WHITE	#2604 POWDER	#2605 POWDER
RH	3684-AO-F5	\$487	\$501	\$501	\$550	\$574
LH	3684-BO-F5	\$487	\$501	\$501	\$550	\$574
RH	4284-AO-F5	\$498	\$512	\$512	\$562	\$586
LH	4284-BO-F5	\$498	\$512	\$512	\$562	\$586
PAIR	7284-JO-F5	\$624	\$640	\$640	\$692	\$718

Note: Maximum Frame Height = 120"

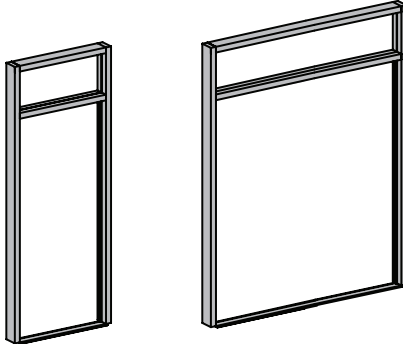

FL500 DOOR FRAME WITH TRANSOM						
HAND	DESCRIPTION	FINISH CODE / FRAME PRICE				
		#10 CLEAR	#20 BRONZE	#81 WHITE	#2604 POWDER	#2605 POWDER
RH	3684-AO-FT5	\$714	\$737	\$737	\$873	\$923
LH	3684-BO-FT5	\$714	\$737	\$737	\$873	\$923
RH	4284-AO-FT5	\$730	\$754	\$754	\$896	\$949
LH	4284-BO-FT5	\$730	\$754	\$754	\$896	\$949
PAIR	7284-JO-FT5	\$889	\$918	\$918	\$1,092	\$1,155

Note: All FL581 Doorframes requiring sidelites are interchangeable with Series FL550 Framing System by using FL555 Snap-In Filler.

Impact Entrances

Butt Hinge/Offset Arm

Butt Hinge – Offset Arm Door Package Includes

- Traditional 1" rd Pull/Push Hardware
- Glass Stops for ¾" or 1" Glazing
- 1½ Pair 4½" x 4" SS Butt Hinges
- Slide Channel installed with Offset Arm
- 3 Pt Lock - Single or Active Leaf
- Top & Bottom Steel Flush Bolts Inactive Leaf
- Keyed Cylinder Exterior
- Thumb Turn Interior
- Door Sweep w/ Weathering

Note: Reference Hardware Section of the Price Catalog for Door Closers and Loose Hardware Items not included in Standard Entrance section.

Note: All Hardware on Powder coat products is furnished in a standard clear finish.

Note: 2 pair of Butt Hinges required with 1" glazing.

Order Number Example: 3696HR-AO (Size and Series) - (Hand or Pair)



SERIES 381 MEDIUM STILE						
HAND	DESCRIPTION	FINISH CODE / DOOR PRICE				
		#10 CLEAR	#20 BRONZE	#81 WHITE	#2604 POWDER	#2605 POWDER
RH	3696HR-AO	\$924	\$955	\$955	\$1,081	\$1,130
LH	3696HR-BO	\$924	\$955	\$955	\$1,081	\$1,130
RH	4296HR-AO	\$958	\$982	\$982	\$1,123	\$1,175
LH	4296HR-BO	\$958	\$982	\$982	\$1,123	\$1,175
PAIR	7296HR-JO	\$1,803	\$1,865	\$1,865	\$2,102	\$2,201

Order Number Example: 3696HS-AO (Size and Series) - (Hand or Pair)



SERIES 581 WIDE STILE						
HAND	DESCRIPTION	FINISH CODE / DOOR PRICE				
		#10 CLEAR	#20 BRONZE	#81 WHITE	#2604 POWDER	#2605 POWDER
RH	3696HS-AO	\$949	\$981	\$981	\$1,121	\$1,174
LH	3696HS-BO	\$949	\$981	\$981	\$1,121	\$1,174
RH	4296HS-AO	\$983	\$1,009	\$1,009	\$1,163	\$1,219
LH	4296HS-BO	\$983	\$1,009	\$1,009	\$1,163	\$1,219
PAIR	7296HS-JO	\$1,854	\$1,917	\$1,917	\$2,182	\$2,289

Note: Add "DM141" to substitute Glass Stops used for 1" Insulated Glass.

Butt Hinge - Offset Arm Frame Package Includes

- 2½" x 5" Open Back Frame
- Snap-in DS501 Door Stop w/pile
- Applied DS202 Header Door stop
- ½" x 4" Threshold – Mill Finish
- Threshold Clips
- Prep for 1½ Pair 4½" x 4" SS Butt Hinges
- Prep for 3 Pt Lock
- Prep for Top & Bottom Flush Bolts (pair)
- Prep for COC
- Transom Frames include FL517(Sash) and FL518(Stop) for Wet Glaze
- Frame assembly fastener package

Note: All Hardware on Powder coat products is furnished in a standard clear finish.

Note: Standard Frame Height for Transom Frames = 10'.

Order Number Example: **3696-BO-FT5** (Size) - (Hand or Pair) - (Type)

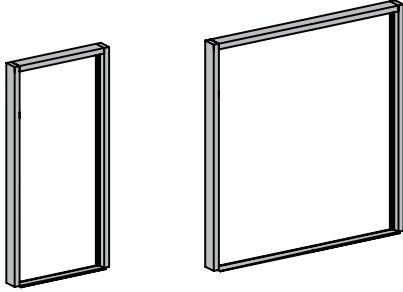

FL500 DOOR FRAME (Non-Transom)						
HAND	DESCRIPTION	FINISH CODE / FRAME PRICE				
		#10 CLEAR	#20 BRONZE	#81 WHITE	#2604 POWDER	#2605 POWDER
RH	3696-AO-F5	\$512	\$527	\$527	\$584	\$610
LH	3696-BO-F5	\$512	\$527	\$527	\$584	\$610
RH	4296-AO-F5	\$523	\$538	\$538	\$595	\$622
LH	4296-BO-F5	\$523	\$538	\$538	\$595	\$622
PAIR	7296-JO-F5	\$649	\$666	\$666	\$726	\$755

Note: Maximum Frame Height = 120"

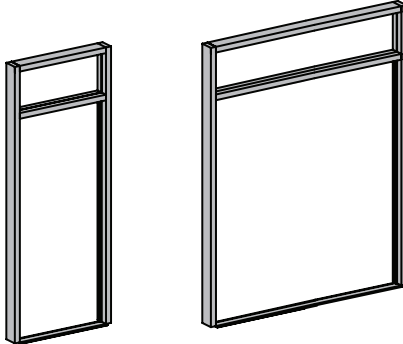

FL500 DOOR FRAME WITH TRANSOM						
HAND	DESCRIPTION	FINISH CODE / FRAME PRICE				
		#10 CLEAR	#20 BRONZE	#81 WHITE	#2604 POWDER	#2605 POWDER
RH	3696-AO-FT5	\$710	\$732	\$732	\$855	\$902
LH	3696-BO-FT5	\$710	\$732	\$732	\$855	\$902
RH	4296-AO-FT5	\$727	\$750	\$750	\$879	\$929
LH	4296-BO-FT5	\$727	\$750	\$750	\$879	\$929
PAIR	7296-JO-FT5	\$886	\$914	\$914	\$1,075	\$1,136

Note: All FL500 Doorframes requiring sidelites are interchangeable with Series FL550 Framing System by using FL555 Snap-In Filler.

Impact Entrances

Butt Hinge/Offset Arm/Panic

Butt Hinge – CVR Panic – Offset Arm Door Package Includes

- Traditional 1" rd rd Panic Pull
- Glass Stops for 3/8" or 1" Glazing
- 1½ Pair 4½" x 4" SS Butt Hinges
- Slide Channel installed with Offset Arm
- DH3692 CVR Touch Bar Panic(s)
- Keyed Cylinder Exterior - Single or Active Leaf
- Door Sweep w/ Weathering

*Note: Reference Hardware Section of the Price Catalog for Door Closers and Loose Hardware Items not included in Standard Entrance section.
Note: All Hardware on Powder coat products is furnished in a standard clear finish.*



Order Number Example: **3684HR-BOP** (Size and Series) - (Hand or Pair)

SERIES 281 NARROW STILE						
HAND	DESCRIPTION	FINISH CODE / DOOR PRICE				
		#10 CLEAR	#20 BRONZE	#81 WHITE	#2604 POWDER	#2605 POWDER
RH	3684HN-AOP	\$1,619	\$1,673	\$1,673	\$1,751	\$1,792
LH	3684HN-BOP	\$1,619	\$1,673	\$1,673	\$1,751	\$1,792
PAIR	7284HN-JOP	\$3,240	\$3,348	\$3,348	\$3,480	\$3,558



SERIES 381 MEDIUM STILE						
HAND	DESCRIPTION	FINISH CODE / DOOR PRICE				
		#10 CLEAR	#20 BRONZE	#81 WHITE	#2604 POWDER	#2605 POWDER
RH	3684HR-AOP	\$1,146	\$1,167	\$1,167	\$1,287	\$1,331
LH	3684HR-BOP	\$1,146	\$1,167	\$1,167	\$1,287	\$1,331
RH	4284HR-AOP	\$1,164	\$1,186	\$1,186	\$1,314	\$1,361
LH	4284HR-BOP	\$1,164	\$1,186	\$1,186	\$1,314	\$1,361
PAIR	7284HR-JOP	\$2,316	\$2,360	\$2,360	\$2,588	\$2,675



SERIES 581 WIDE STILE						
HAND	DESCRIPTION	FINISH CODE / DOOR PRICE				
		#10 CLEAR	#20 BRONZE	#81 WHITE	#2604 POWDER	#2605 POWDER
RH	3684HS-AOP	\$1,167	\$1,189	\$1,189	\$1,320	\$1,368
LH	3684HS-BOP	\$1,167	\$1,189	\$1,189	\$1,320	\$1,368
RH	4284HS-AOP	\$1,186	\$1,208	\$1,208	\$1,348	\$1,399
LH	4284HS-BOP	\$1,186	\$1,208	\$1,208	\$1,348	\$1,399
PAIR	7284HS-JOP	\$2,358	\$2,404	\$2,404	\$2,655	\$2,749

Note: Add "DM141" to substitute Glass Stops used for 1" Insulated Glass.

Butt hung – CVR Panic – Offset Arm Frame Package Includes

- 2½" x 5" Open Back Frame
- Snap-in DS501 Door Stop w/pile
- Applied DS202 Header Door stop
- ½" x 5" Bumper Threshold – Mill Finish
- Threshold Clips
- Prep for 1½ Pair 4½" x 4" SS Butt Hinges
- Prep for DH3692 CVR Panic(s)
- Prep for COC
- Transom Frames include FL517(Sash) and FL518(Stop) for Wet Glaze
- Frame assembly fastener package

Note: All Hardware on Powder coat products is furnished in a standard clear finish.

Note: Standard Frame Height for Transom Frames = 10'.

Order Number Example: **3684-BOP-FT5** (Size) - (Hand or Pair) - (Type)

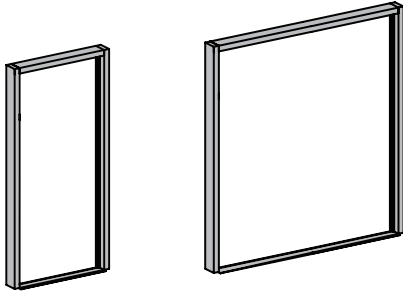

FL500 DOOR FRAME (Non-Transom)						
HAND	DESCRIPTION	FINISH CODE / FRAME PRICE				
		#10 CLEAR	#20 BRONZE	#81 WHITE	#2604 POWDER	#2605 POWDER
RH	3684-AOP-F5	\$494	\$508	\$508	\$557	\$581
LH	3684-BOP-F5	\$494	\$508	\$508	\$557	\$581
RH	4284-AOP-F5	\$505	\$519	\$519	\$569	\$593
LH	4284-BOP-F5	\$505	\$519	\$519	\$569	\$593
PAIR	7284-JOP-F5	\$631	\$647	\$647	\$699	\$725

Note: Maximum Frame Height = 120"

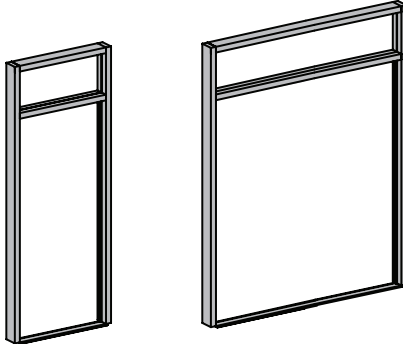

FL500 DOOR FRAME WITH TRANSOM						
HAND	DESCRIPTION	FINISH CODE / FRAME PRICE				
		#10 CLEAR	#20 BRONZE	#81 WHITE	#2604 POWDER	#2605 POWDER
RH	3684-AOP-FT5	\$721	\$744	\$744	\$880	\$930
LH	3684-BOP-FT5	\$721	\$744	\$744	\$880	\$930
RH	4284-AOP-FT5	\$737	\$760	\$760	\$903	\$956
LH	4284-BOP-FT5	\$737	\$760	\$760	\$903	\$956
PAIR	7284-JOP-FT5	\$896	\$924	\$924	\$1,099	\$1,162

Note: All FL581 Doorframes requiring sidelites are interchangeable with Series FL550 Framing System by using FL555 Snap-In Filler.

Impact Entrances

Butt Hinge/Offset Arm/Panic

Butt Hinge – CVR Panic – Offset Arm Door Package Includes

- Traditional 1" rd rd Panic Pull
- Glass Stops for 3/8" Glazing
- 1 1/2 Pair 4 1/2" x 4" SS Butt Hinges
- Slide Channel installed with Offset Arm
- DH3692 CVR Touch Bar Panic(s)
- Keyed Cylinder Exterior - Single or Active Leaf
- Door Sweep w/ Weathering

Note: Reference Hardware Section of the Price Catalog for Door Closers and Loose Hardware Items not included in Standard Entrance section.

Note: All Hardware on Powder coat products is furnished in a standard clear finish.

Note: 2 pair of Butt Hinges required with 1" glazing.

Order Number Example: **3696HR-AOP** (Size and Series) - (Hand or Pair)

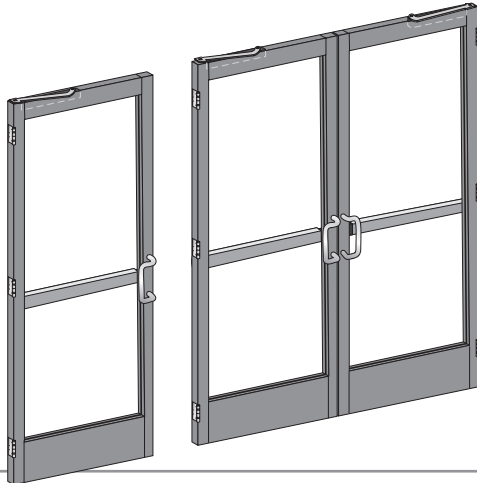

SERIES 381 MEDIUM STILE						
HAND	DESCRIPTION	FINISH CODE / DOOR PRICE				
		#10 CLEAR	#20 BRONZE	#81 WHITE	#2604 POWDER	#2605 POWDER
RH	3696HR-AOP	\$1,171	\$1,195	\$1,195	\$1,328	\$1,377
LH	3696HR-BOP	\$1,171	\$1,195	\$1,195	\$1,328	\$1,377
RH	4296HR-AOP	\$1,193	\$1,216	\$1,216	\$1,358	\$1,410
LH	4296HR-BOP	\$1,193	\$1,216	\$1,216	\$1,358	\$1,410
PAIR	7296HR-JOP	\$2,370	\$2,418	\$2,418	\$2,672	\$2,767

Order Number Example: **3696HR-AOP** (Size and Series) - (Hand or Pair)



SERIES 581 WIDE STILE						
HAND	DESCRIPTION	FINISH CODE / DOOR PRICE				
		#10 CLEAR	#20 BRONZE	#81 WHITE	#2604 POWDER	#2605 POWDER
RH	3696HR-AOP	\$1,197	\$1,221	\$1,221	\$1,368	\$1,421
LH	3696HR-BOP	\$1,197	\$1,221	\$1,221	\$1,368	\$1,421
RH	4296HR-AOP	\$1,219	\$1,243	\$1,243	\$1,398	\$1,454
LH	4296HR-BOP	\$1,219	\$1,243	\$1,243	\$1,398	\$1,454
PAIR	7296HR-JOP	\$2,420	\$2,470	\$2,470	\$2,751	\$2,856

Note: Add "DM141" to substitute Glass Stops used for 1" Insulated Glass.

Butt hung – CVR Panic – Offset Arm Frame Package Includes

- 2½" x 5" Open Back Frame
- Snap-in DS501 Door Stop w/pile
- Applied DS202 Header Door stop
- ½" x 5" Bumper Threshold – Mill Finish
- Threshold Clips
- Prep for 1½ Pair 4½" x 4" SS Butt Hinges
- Prep for DH3692 CVR Panic(s)
- Prep for COC
- Transom Frames include FL517(Sash) and FL518(Stop) for Wet Glaze
- Frame assembly fastener package

Note: All Hardware on Powder coat products is furnished in a standard clear finish.

Note: Standard Frame Height for Transom Frames = 10'.

Order Number Example: **3696-BOP-FT5 (Size) - (Hand or Pair) - (Type)**

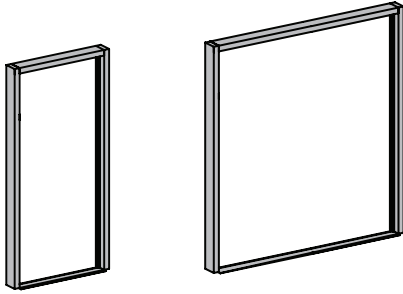

FL500 DOOR FRAME (Non-Transom)						
HAND	DESCRIPTION	FINISH CODE / FRAME PRICE				
		#10 CLEAR	#20 BRONZE	#81 WHITE	#2604 POWDER	#2605 POWDER
RH	3696-AOP-F5	\$519	\$534	\$534	\$591	\$617
LH	3696-BOP-F5	\$519	\$534	\$534	\$591	\$617
RH	4296-AOP-F5	\$530	\$545	\$545	\$602	\$629
LH	4296-BOP-F5	\$530	\$545	\$545	\$602	\$629
PAIR	7296-JOP-F5	\$656	\$673	\$673	\$733	\$761

Note: Maximum Frame Height = 120"

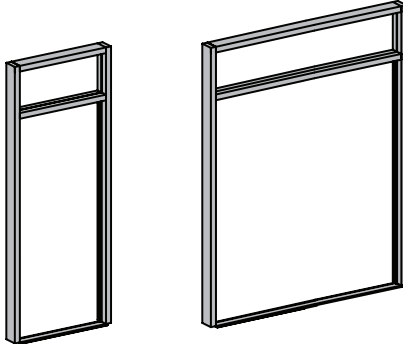

FL500 DOOR FRAME WITH TRANSOM						
HAND	DESCRIPTION	FINISH CODE / FRAME PRICE				
		#10 CLEAR	#20 BRONZE	#81 WHITE	#2604 POWDER	#2605 POWDER
RH	3696-AOP-FT5	\$718	\$740	\$740	\$863	\$910
LH	3696-BOP-FT5	\$718	\$740	\$740	\$863	\$910
RH	4296-AOP-FT5	\$734	\$757	\$757	\$886	\$935
LH	4296-BOP-FT5	\$734	\$757	\$757	\$886	\$935
PAIR	7296-JOP-FT5	\$893	\$921	\$921	\$1,082	\$1,143

Note: All FL500 Doorframes requiring sidelites are interchangeable with Series FL550 Framing System by using FL555 Snap-In Filler.

Page Left Intentionally Blank



Section D2
Table of Contents



IMPACT ENTRANCES

Adds, Substitutions, and Modifications

Glass Stops	1
Push / Pulls	1
Top Rail Substitutions - Stock Door.....	2
Bottom Rail Substitutions - Stock Door	3
Horizontal Muntin Mid-Rail Adds - Standard Door	4
Hinge Modifications and Substitutions	5
Cylinder Substitutions	6
Panic / Exit Devices.....	7

Page Left Intentionally Blank



GLASS STOPS									
ITEM	DESCRIPTION	LENGTH	P/N	FINISH CODE / DOOR PRICE					
				#10	#20	#81	#99	#89	
DG505 	Substitute DG505 1" Glass Stops	N/A	DM006	N/C					
	Substitute DG504 5/16" Dry Glaze	N/A	DM007	N/C					

PUSH / PULL									
ITEM	DESCRIPTION	LENGTH	P/N	FINISH CODE / DOOR PRICE					
				#10	#27	#81	#99	#89	
PB401  PB401	Substitute DH41 Back to Back Push Bars	36"	DM010	\$30	\$35	Default Finish is #10 unless otherwise specified			
		42"	DM011	\$36	\$46				
PH401  PH401	Substitute DH42 Back to Back Pull Handles	36"	DM013	\$0	\$0				
		42"	DM014	\$0	\$0				

Impact Entrances

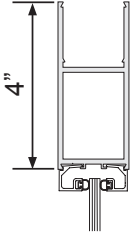
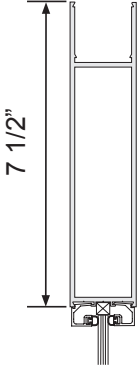
Adds, Substitutions, & Modifications

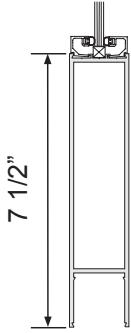
TOP RAIL								
ITEM	DESCRIPTION	LENGTH	P/N	FINISH CODE / DOOR PRICE				
				#10	#20	#81	#99	#89
	Substitute D102 for D101	36"	DM020	\$8	\$10	\$10	\$10	\$13
		42"	DM021	\$10	\$12	\$12	\$12	\$15
	Substitute D108 for D102	36"	DM023	\$10	\$13	\$13	\$13	\$18
		42"	DM024	\$12	\$15	\$15	\$15	\$20

BOTTOM RAIL								
ITEM	DESCRIPTION	LENGTH	P/N	FINISH CODE / DOOR PRICE				
				#10	#20	#81	#99	#89
	Substitute D108 for D102	36"	DM032	\$10	\$13	\$13	\$13	\$18
		42"	DM033	\$12	\$15	\$15	\$15	\$20
	Substitute D109 for D102	36"	DM035	\$13	\$16	\$16	\$16	\$21
		42"	DM036	\$15	\$18	\$18	\$18	\$23
	Substitute D109 for D108	36"	DM038	\$5	\$7	\$7	\$7	\$10
		42"	DM039	\$7	\$9	\$9	\$9	\$12

Impact Entrances

Adds, Substitutions, & Modifications

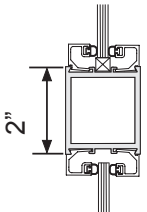
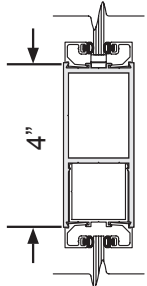
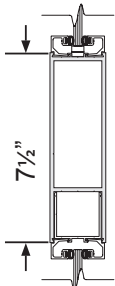
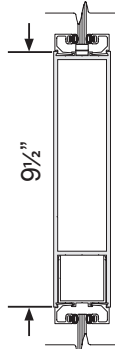
HORIZONTAL MUNTIN								
ITEM	DESCRIPTION	LENGTH	P/N	FINISH CODE / DOOR PRICE				
				#10	#20	#81	#99	#89
	Add 2" Horizontal Muntin	36"	DM053	\$132	\$135	\$135	\$135	\$141
		42"	DM054	\$135	\$141	\$141	\$141	\$146
	Add 4" Mid-Rail	36"	DM056	\$135	\$141	\$141	\$141	\$146
		42"	DM057	\$138	\$144	\$144	\$144	\$152
	Add 7-1/2" Mid-Rail	36"	DM060	\$149	\$152	\$152	\$152	\$166
		42"	DM061	\$157	\$163	\$163	\$163	\$179
	Add 9-1/2" Mid-Rail	36"	DM063	\$157	\$163	\$163	\$163	\$182
		42"	DM064	\$168	\$174	\$174	\$174	\$196

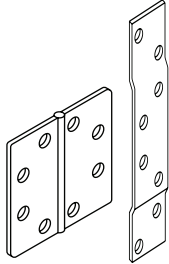
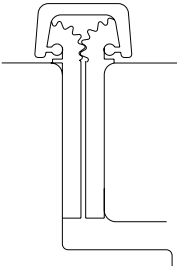

HINGE								
ITEM	DESCRIPTION	LENGTH	P/N	FINISH CODE / DOOR PRICE				
				#10	#20	#81	#99	#89
DH110SS 	Add DH110SS Butt Hinge (Stainless Steel), Includes back-up plates and screws	N/A	DM082	\$55	\$55	Default Finish is #10 unless otherwise specified		
DH111HD 	Substitute HD Continuous Gear Hinge for Butt Hinge	84"	DM090	\$130	\$170			
		96"	DM091	\$140	\$195			

Impact Entrances

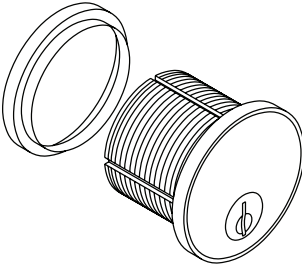
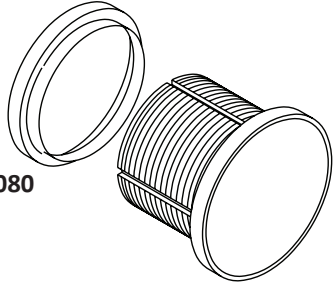
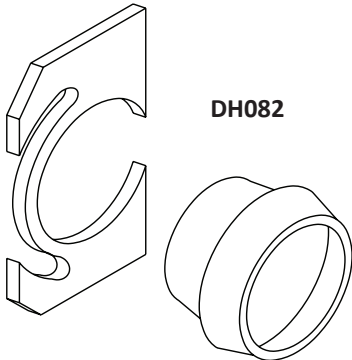
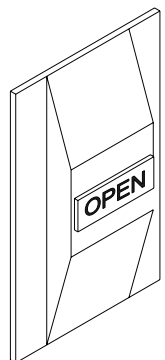
Adds, Substitutions, & Modifications

CYLINDERS								
ITEM	DESCRIPTION	LENGTH	P/N	FINISH CODE / DOOR PRICE				
				#10	#20	#81	#99	#89
 <p>DH078</p>	<p>Substitute DH078 Cylinder</p>	N/A	DM120	N/C	N/C			
 <p>DH080</p>	<p>Substitute DH080 Dummy Cylinder</p>	N/A	DM121	N/C	N/C			
 <p>DH082</p>	<p>Add DH082 Cylinder Guard</p>	N/A	DM122	\$10	\$10			
 <p>DH074</p>	<p>Add DH074 Lock Indicator</p>	N/A	DM123	\$10	\$10			

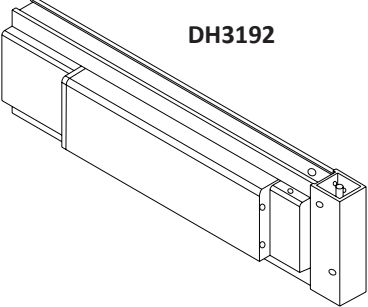
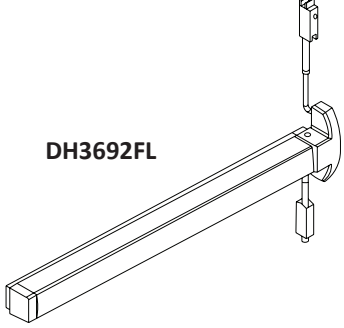
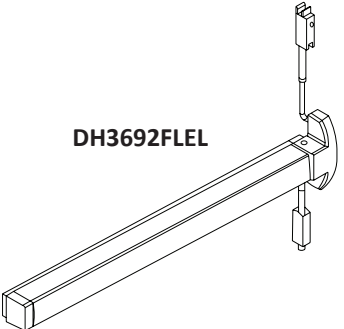
Default Finish is #10 unless otherwise specified

PANICS / EXIT DEVICES											
ITEM	DESCRIPTION	LENGTH	P/N	FINISH CODE / DOOR PRICE							
				#10	#20	#81	#99	#89			
 <p>DH3192</p>	<p>Add First Choice 3192 Mid Panel Panic (Priced Per Leaf)</p>	36"	DM138	\$620	\$630	\$630	\$640	\$650			
		42"	DM139	\$640	\$650	\$650	\$660	\$670			
 <p>DH3692FL</p>	<p>Add First Choice 3692FL Panic (Priced Per Leaf)</p>	36"	DM141	\$380	\$385	Default Finish is #10 unless otherwise specified					
		42"	DM142	\$385	\$390						
 <p>DH3692FLEL</p>	<p>Add First Choice 3692FLEL Panic (Priced Per Leaf)</p>	36"	DM147	\$1510	\$1510						
		42"	DM148	\$1540	\$1540						
 <p>DHC-EPT</p>	<p>Add Securitron Electrical Power Transfer (Priced Per Leaf)</p>	N/A	DM180	\$185							

Impact Entrances

Adds, Substitutions, & Modifications

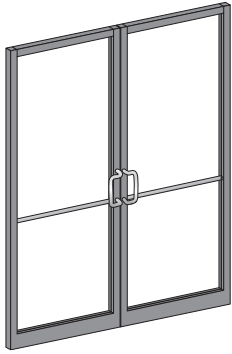
DOOR WIDTH ADD								
ITEM	DESCRIPTION	STILE	P/N	FINISH CODE / DOOR PRICE				
				#10	#20	#81	#99	#89
	ADD Pair Door Width >72" up to 84"	HR	DM207	\$170	\$180	\$180	\$190	\$200
		HS	DM208	\$180	\$190	\$190	\$200	\$210

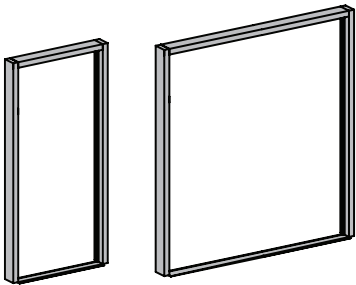
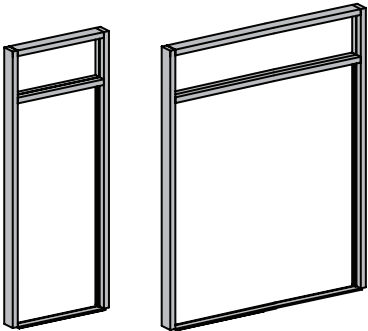
FRAME WIDTH ADD								
ITEM	DESCRIPTION	P/N	FINISH CODE / DOOR PRICE					
			#10	#20	#81	#99	#89	
	Non Transom Pair Door Frame Door Opening Width >72" Up To 84"	DM221	\$25	\$30	\$30	\$35	\$40	
	Transom Pair Door Frame Door Opening Width >72" Up To 84"	DM231	\$30	\$35	\$35	\$40	\$45	

Section E
IMPACT-RESISTANT STOREFRONTS
Table of Contents

FL500 Impact-Resistant Storefront System.....E1
FL550 Impact-Resistant Storefront System.....E2
FL550T Thermal Impact-Resistant Storefront
System.....E3

Page Left Intentionally Blank

Section E1 Table of Contents



2½" x 5"

	<i>Page</i>
High Velocity Hurricane Applications	1-2
Standard Framing Extrusions.....	3
Door Framing Extrusions	4
Accessories	5
Steel Reinforcing.....	6
Glazing Infill Charts and Setting Block/Setting Chair Charts	6

Page Left Intentionally Blank

High Velocity Hurricane Zone Applications

Series FL500 Wet Glazed Hurricane Impact-Resistant Storefront System

Qualified System Configuration Chart

Design Pressure P.S.F.	Intermediate Vertical Mullion	Wall Jamb Mullion	Maximum Mullion Span	Maximum Mullion Spacing CL to CL	Maximum Glass Size		Qualified Glass Types
					D.L.O. W x H	Sq. Ft.	
+60/-60	FL516/FL505 Heavy Duty Mullion	FL501	120"	48"	45½" x 96"	30.3	A-B
+65/-65	FL504/FL505	FL501	89"	48"	45½" x 84"	26.5	A-B
+70/-80	FL504/FL505 with SR504 Steel Reinforcement	FL501	120"	60"	57½" x 96"	38.3	A

Hurricane Impact-Resistant Products Disclaimer Note

Coral's hurricane impact-resistant products meet a variety of test standards for applications in coastal construction regions satisfying the demands for wind-borne debris hazards and high-velocity winds associated with hurricanes. All of Coral's hurricane impact-resistant products are independent laboratory tested based on a variety of test standards for air infiltration, water resistance, structural loads, missile impact and air-pressure cycling based ASTM and/or Florida Building Code. The informational chart above is intended to provide recommended limits in frame heights, glass sizes and design pressures based on product testing. When exceeding conditions listed above it is recommended to consult with licensed structural engineer or contact Coral Architectural Products.

Qualified Glass Types

Glass Type	Glass Composition			Interlayer Manufacturer	Glass Identification
	Exterior Lite	Interlayer	Interior Lite		
⅝" Monolithic Glass	¼" Heat Strengthened Glass	.075 Vanceva Interlayer	¼" Heat Strengthened Glass	Solutia	A
⅝" Monolithic Glass	¼" Heat Strengthened Glass	.090 Saflex PVB Interlayer	¼" Heat Strengthened Glass	Solutia	B

Comparative Analysis of Glass Based on ASTM E-1300

Dade County Building Compliance Office allows comparative analysis of tested glass types provided the following five conditions are met:

1. Does not exceed maximum cyclic pressure tested.
2. Does not exceed maximum span of mullion tested.
3. Does not exceed maximum mullion spacing of mullion tested.
4. Does not exceed maximum square footage of largest lite tested.
5. Does not exceed aspect ratio of 5:1 (in a rectangular configuration, the ratio of the long-side to the short-side is defined as the aspect ratio).

High Velocity Hurricane Zone Applications

Series FL500 Dry Glazed Hurricane Impact-Resistant Storefront System

Qualified System Configuration Chart

Design Pressure P.S.F.	Intermediate Vertical Mullion	Wall Jamb Mullion	Maximum Mullion Span	Maximum Mullion Spacing CL to CL	Maximum Glass Size		Qualified Glass Types
					D.L.O. W x H	Sq. Ft.	
+45/-45	FL516/FL505 Heavy Duty Mullion	FL501	120"	60"	57½" x 96"	38.3	D
+70/-70	FL504/FL505 with SR504 Steel Reinforcement	FL501	120"	60"	57½" x 96"	38.3	D

Hurricane Impact-Resistant Products Disclaimer Note

Coral’s hurricane impact-resistant products meet a variety of test standards for applications in coastal construction regions satisfying the demands for wind-borne debris hazards and high-velocity winds associated with hurricanes. All of Coral’s hurricane impact-resistant products are independent laboratory tested based on a variety of test standards for air infiltration, water resistance, structural loads, missile impact and air-pressure cycling based ASTM and/or Florida Building Code. The informational chart above is intended to provide recommended limits in frame heights, glass sizes and design pressures based on product testing. When exceeding conditions listed above it is recommended to consult with licensed structural engineer or contact Coral Architectural Products.







Qualified Glass Types

Glass Type	Glass Composition			Interlayer Manufacturer	Glass Identification
	Exterior Lite	Interlayer	Interior Lite		
⅝" Monolithic Glass	¼" Heat Strengthened Glass	.090 Sentry Glas Interlayer (Dry-Glazed Application)	¼" Heat Strengthened Glass	Kuraray	D

Comparative Analysis of Glass Based on ASTM E-1300

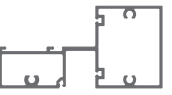
Florida Product Control Office allows comparative analysis of tested glass types provided the following five conditions are met:





1. Does not exceed maximum cyclic pressure tested.
2. Does not exceed maximum span of mullion tested.
3. Does not exceed maximum mullion spacing of mullion tested.
4. Does not exceed maximum square footage of largest lite tested.
5. Does not exceed aspect ratio of 5:1 (in a rectangular configuration, the ratio of the long-side to the short-side is defined as the aspect ratio).

STANDARD FRAMING EXTRUSIONS								
PART DESCRIPTION	PART NO.	PART LENGTH	PCS. PER BOX	FINISH CODE/STOCK LENGTH LIST PRICE				
				#10 CLEAR	#20 BRONZE	#81 WHITE	#2604 POWDER	#2605 POWDER
 Head/Wall Jamb (Deep Pocket)	FL501	24'	3	\$273	\$293	\$293	\$321	\$351
 Sill/Optional Head (Deep Pocket)	FL502	24'	4	\$230	\$248	\$248	\$252	\$274
 Glass Stop	FL503	24'	10	\$75	\$81	\$81	\$113	\$128
 Intermediate Horizontal	FL506	24'	4	\$255	\$266	\$266	\$341	\$373
 Standard Vertical Mullion & Door-frame Jamb	FL504	24'	4	\$215	\$225	\$225	\$276	\$307
 Heavy Wall Vertical Mullion	FL516	24'	4	\$277	\$292	\$292	\$344	\$375
 Pocket Filler (For use with FL504 & FL516)	FL505	24'	5	\$131	\$142	\$142	\$154	\$169
 Sub-Sill Flashing	FL519	24'-3"	10	\$124	\$133	\$133	\$149	\$164







Note: Add Finish Code to the Part Number when ordering (Ex: **FL501-10** for Clear Anodized Finish)





FL500·2½" x 5"

Impact-Resistant Screw-Spline Storefront

DOOR FRAMING EXTRUSIONS								
PART DESCRIPTION	PART NO.	PART LENGTH	PCS. PER BOX	FINISH CODE/STOCK LENGTH LIST PRICE				
				#10 CLEAR	#20 BRONZE	#81 WHITE	#2604 POWDER	#2605 POWDER
 Door Header/Transom Bar	FL507	24'	2	\$320	\$333	\$333	\$436	\$476
 Door Header/Transom Bar (C.O.C.W./O.A., 2½ x 5)	FL562	24'	4	\$238	\$247	\$247	\$392	\$439
 Flat Filler	FL515	24'	10	\$83	\$90	\$90	\$130	\$149
 Transom Sash	FL517	24'	10	\$59	\$65	\$65	\$99	\$114
 Transom Glass Stop	FL518	24'	10	\$35	\$38	\$38	\$82	\$98

Note: Add Finish Code to the Part Number when ordering (Ex: FL501-10 for Clear Anodized Finish)

ACCESSORIES			
PART DESCRIPTION	PART NO.	QUANTITY	PRICE PER BOX
 Spline Screw #14 x 1 HHSTS (Assembly Screw)	AS16	100 (AS16-1)	\$12
 #6 x 3/8" PPH Type AB (Attaches End Dams)	AS21	100 (AS21-1)	\$5
 Setting Chair (Two Per Lite Required at Sill Member)	CS500-1	50 (CS500-2)	\$90
 End Dam for Sill Flashing	ED519-1	20 (ED519-2)	\$33
 Exterior EPDM Gasket	NG1	300 FT. (Per Roll)	\$136
 1/4" Interior Spacer Gasket	NG14	500 FT. (Per Roll)	\$229
 Dry Glazed Gasket	NG15	500 FT. (Per Roll)	\$332

ACCESSORIES			
PART DESCRIPTION	PART NO.	QUANTITY	PRICE PER BOX
 4" Long EPDM Setting Block for 1/16" Glass (Two Per Lite at Transom Sash)	SB11	50 (SB11-1)	\$35
 4" Long EPDM Setting Block for 1/16" Glass (Two Per Lite)	SB13	100 (SB13-1)	\$128
 4" Long EPDM Setting Block for 1/16" Glass (Two Per Lite at inverted horizontal)	SB20	100 (SB20-1)	\$40
 Water Diverter (Horizontal - Two Per Lite)	WD200-1	50 (WD200-2)	\$62
 Joint Sealant Tape (1/8" x 1/2" for Sealing Horizontal to Vertical Member Connections)	SM5601	30 FT. (Per Roll)	\$37

FL500·2½" x 5

Thermal Screw-Spline Storefront

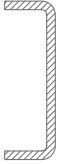
STEEL REINFORCING			
PART DESCRIPTION	PART NO.	QUANTITY	PRICE
 <p>1½" x 4½" x ¼" with Zinc Chromate Primer Steel Reinforcing</p>	SR504	10'-0"	\$292

GLAZING INFILL CHART					
SYSTEM	REGLET WIDTH	GLAZING TECHNIQUE	INFILL THICKNESS	GASKET COMBINATIONS	
FL500	9/16"	Wet Glazed	9/16"	NG14 (DOW995)	NG1
		Dry Glazed	9/16"	NG15 (DOW995)	NG1

SETTING BLOCK AND SETTING CHAIR CHART					
GLASS SIZE	PART DESCRIPTION	PART NO.	GLAZING APPLICATION	SETTING BLOCK PART NO.	SETTING CHAIR PART NO.
9/16"	Sill Member	FL502	Exterior Glazed	SB13	CS500-1
9/16"	Intermediate Horizontal	FL506	Exterior Glazed	SB13	Not Required
		FL506	Interior Glazed	SB20	Not Required

Section E2 Table of Contents

FL550 

HURRICANE IMPACT-RESISTANT STOREFRONT

2½" x 5"

	<i>Page</i>
High Velocity Hurricane Applications	1-2
Standard Framing Extrusions.....	3
Door Framing Extrusions	4
Accessories	5
Glazing Infill Charts and Setting Block/Setting Chair Charts	6

Page Left Intentionally Blank

High Velocity Hurricane Zone Applications

Series FL550 Wet Glazed Hurricane Impact-Resistant Storefront System

Qualified System Configuration Chart

Design Pressure P.S.F.	Intermediate Vertical Mullion	Wall Jamb Mullion	Maximum Mullion Span	Maximum Mullion Spacing CL to CL	Maximum Glass Size		Qualified Glass Types
					D.L.O. W x H	Sq. Ft.	
+60/-60	FL566/FL555 Heavy Duty Mullion	FL551	120"	48"	45½" x 96"	30.3	IA-IB
+65/-65	FL554/FL555	FL551	89"	48"	45½" x 84"	26.5	IA-IB
+70/-80	FL554/FL555 with SR504 Steel Reinforcement	FL551	120"	60"	57½" x 96"	38.3	1A

Hurricane Impact-Resistant Products Disclaimer Note

Coral's hurricane impact-resistant products meet a variety of test standards for applications in coastal construction regions satisfying the demands for wind-borne debris hazards and high-velocity winds associated with hurricanes. All of Coral's hurricane impact-resistant products are independent laboratory tested based on a variety of test standards for air infiltration, water resistance, structural loads, missile impact and air-pressure cycling based ASTM and/or Florida Building Code. The informational chart above is intended to provide recommended limits in frame heights, glass sizes and design pressures based on product testing. When exceeding conditions listed above it is recommended to consult with licensed structural engineer or contact Coral Architectural Products.

Qualified Glass Types

Glass Type	Glass Composition			Interlayer Manufacturer	Glass Identification
	Exterior Lite	Air Space/ Spacer Type	Interior Lite		
1½" Insulated Glass	¼" Heat Strengthened Glass	½" Air Space with Aluminum Box Spacer	¼" Heat Strengthened Glass .075 Vanceva Interlayer ¼" Heat Strengthened Glass	Solutia	IA
1½" Insulated Glass	¼" Heat Strengthened Glass	½" Air Space with Aluminum Box Spacer	¼" Heat Strengthened Glass .090 Saflex Interlayer ¼" Heat Strengthened Glass	Solutia	IB

Comparative Analysis of Glass Based on ASTM E-1300

Dade County Building Compliance Office allows comparative analysis of tested glass types provided the following five conditions are met:

1. Does not exceed maximum cyclic pressure tested.
2. Does not exceed maximum span of mullion tested.
3. Does not exceed maximum mullion spacing of mullion tested.
4. Does not exceed maximum square footage of largest lite tested.
5. Does not exceed aspect ratio of 5:1 (in a rectangular configuration, the ratio of the long-side to the short-side is defined as the aspect ratio).

High Velocity Hurricane Zone Applications

Series FL550 Dry Glazed Hurricane Impact-Resistant Storefront System

Qualified System Configuration Chart

Design Pressure P.S.F.	Intermediate Vertical Mullion	Wall Jamb Mullion	Maximum Mullion Span	Maximum Mullion Spacing CL to CL	Maximum Glass Size		Qualified Glass Types
					D.L.O. W x H	Sq. Ft.	
+45/-45	FL566/FL555 Heavy Duty Mullion	FL551	120"	60"	57½" x 96"	38.3	ID
+70/-70	FL554/FL555 with SR504 Steel Reinforcement	FL551	120"	60"	57½" x 96"	38.3	ID

Hurricane Impact-Resistant Products Disclaimer Note

Coral's hurricane impact-resistant products meet a variety of test standards for applications in coastal construction regions satisfying the demands for wind-borne debris hazards and high-velocity winds associated with hurricanes. All of Coral's hurricane impact-resistant products are independent laboratory tested based on a variety of test standards for air infiltration, water resistance, structural loads, missile impact and air-pressure cycling based ASTM and/or Florida Building Code. The informational chart above is intended to provide recommended limits in frame heights, glass sizes and design pressures based on product testing. When exceeding conditions listed above it is recommended to consult with licensed structural engineer or contact Coral Architectural Products.









Qualified Glass Types

Glass Type	Glass Composition			Interlayer Manufacturer	Glass Identification
	Exterior Lite	Air Space/ Spacer Type	Interior Lite		
1⅝" Laminated Glass	¼" Heat Strengthened Glass or Tempered	½" Air Space with Aluminum Box Spacer	¼" Heat Strengthened Glass .090 Sentry Glass Interlayer ¼" Heat Strengthened Glass	DuPont™	ID

Comparative Analysis of Glass Based on ASTM E-1300

Florida Product Control Office allows comparative analysis of tested glass types provided the following five conditions are met:







1. Does not exceed maximum cyclic pressure tested.
2. Does not exceed maximum span of mullion tested.
3. Does not exceed maximum mullion spacing of mullion tested.
4. Does not exceed maximum square footage of largest lite tested.
5. Does not exceed aspect ratio of 5:1 (in a rectangular configuration, the ratio of the long-side to the short-side is defined as the aspect ratio).

STANDARD FRAMING EXTRUSIONS								
PART DESCRIPTION	PART NO.	PART LENGTH	PCS. PER BOX	FINISH CODE/STOCK LENGTH LIST PRICE				
				#10 CLEAR	#20 BRONZE	#81 WHITE	#2604 POWDER	#2605 POWDER
 Head/Wall Jamb (Deep Pocket)	FL551	24'	4	\$273	\$293	\$293	\$312	\$341
 Sill/Optional Head (Deep Pocket)	FL552	24'	4	\$234	\$252	\$252	\$251	\$271
 Glass Stop	FL553	24'	10	\$70	\$76	\$76	\$109	\$124
 Intermediate Horizontal	FL556	24'	4	\$249	\$261	\$261	\$323	\$352
 Standard Vertical Mullion & Door-frame Jamb	FL554	24'	4	\$215	\$225	\$225	\$268	\$296
 Heavy Wall Vertical Mullion	FL566	24'	4	\$277	\$292	\$292	\$336	\$365
 Pocket Filler (For use with FL554 & FL566)	FL555	24'	5	\$130	\$141	\$141	\$152	\$168
 Sub-Sill	FL519	24'	10	\$124	\$133	\$133	\$149	\$164
 High Performance Sub-Sill	FL539	24'	10	\$197	\$207	\$207	\$275	\$304













Note: Add Finish Code to the Part Number when ordering (Ex: FL551-10 for Clear Anodized Finish)

FL550·2½" x 5"

Impact-Resistant Screw-Spline Storefront

DOOR FRAMING EXTRUSIONS								
PART DESCRIPTION	PART NO.	PART LENGTH	PCS. PER BOX	FINISH CODE/STOCK LENGTH LIST PRICE				
				#10 CLEAR	#20 BRONZE	#81 WHITE	#2604 POWDER	#2605 POWDER
 Door Header/Transom Bar	FL507	24'	2	\$320	\$333	\$333	\$436	\$476
 Door Header/Transom Bar (C.O.C.W./O.A., 2½ x 5)	FL562	24'	4	\$238	\$247	\$247	\$392	\$439
 Flat Filler	FL515	24'	10	\$83	\$90	\$90	\$130	\$149
 Transom Sash ($\frac{1}{16}$ " Infill)	FL517	24'	10	\$59	\$65	\$65	\$99	\$114
 Transom Glass Stop	FL518	24'	10	\$35	\$38	\$38	\$82	\$98
 Transom Sash (1- $\frac{3}{16}$ " Infill)	FL567	24'	10	\$65	\$71	\$71	\$103	\$118

Note: Add Finish Code to the Part Number when ordering (Ex: FL501-10 for Clear Anodized Finish)

ACCESSORIES				ACCESSORIES			
PART DESCRIPTION	PART NO.	PART LENGTH	PRICE PER BOX	PART DESCRIPTION	PART NO.	PART LENGTH	PRICE PER BOX
 Spline Screw #14 x 1 HHSTS (Assembly Screw)	AS16	100 (AS16-1)	\$12	 4" Long EPDM Setting Block for 1¹/₁₆" Glass (Two Per Lite at transom sash)	SB7	100 (SB7-1)	\$86
 #6 x 3/8" PPH Type AB (Attaches End Dams)	AS21	100 (AS21-1)	\$5	 4" Long EPDM Setting Block for 1¹/₁₆" Glass (Two Per Lite at horizontal and sill)	SB15	100 (SB15-1)	\$148
 Setting Chair (Two Per Lite Required at Sill Member)	CS500-1	50 (CS500-2)	\$90	 4" Long EPDM Setting Block for 1¹/₁₆" Glass (Two Per Lite at inverted horizontal)	SB16	100 (SB16-1)	\$128
 End Dam for Sill Flashing	ED519-1	20 (ED519-2)	\$33	 Water Diverter (Horizontal - Two Per Lite)	WD300-1	50 (WD300-2)	\$62
 Exterior EPDM Gasket	NG1	300 FT. (Per Roll)	\$136	 Joint Sealant Tape (1/8" x 1/2" for Sealing Horizontal to Vertical Member Connections)	SM5601	30 FT. (Per Roll)	\$37
 EPDM Gasket for DS550 Door stop at Doorjamb	NG5	500 FT. (Per Roll)	\$275				
 1/4" Interior Spacer Gasket	NG14	500 FT. (Per Roll)	\$229				
 Dry Glazed Gasket	NG15	500 FT. (Per Roll)	\$332				

FL550·2½" x 5"

Impact-Resistant Screw-Spline Storefront

STEEL REINFORCING			
PART DESCRIPTION	PART NO.	QUANTITY LENGTH	PRICE
 1½" x 4⅝" x ¼" with Zinc Chromate Primer Steel Reinforcing	SR504	x1	\$292
		10'-0"	

GLAZING INFILL CHART					
SYSTEM	REGLET WIDTH	GLAZING TECHNIQUE	INFILL THICKNESS	GASKET COMBINATIONS	
FL550	1½"	Wet Glazed	1⅝"	NG14 <small>(DOW995)</small>	NG1
		Dry Glazed	1⅝"	NG15	NG1

SETTING BLOCK AND SETTING CHAIR CHART					
GLASS SIZE	PART DESCRIPTION	PART NO.	GLAZING APPLICATION	SETTING BLOCK PART NO.	SETTING CHAIR PART NO.
1⅝"	Sill Member	FL552	Exterior Glazed	SB15	CS500-1
1⅝"	Intermediate Horizontal	FL556	Exterior Glazed	SB15	Not Required
		FL556	Interior Glazed	SB16	Not Required

Section E3 Table of Contents



2½" x 5"

	<i>Page</i>
High Velocity Hurricane Applications	1
Standard Framing Extrusions.....	2
Accessories	3
Glazing Infill Charts and Setting Block/Setting Chair Charts	4

Page Left Intentionally Blank

High Velocity Hurricane Zone Applications

Series FL550T Thermal Dry Glazed Hurricane Impact-Resistant Storefront System

Qualified System Configuration Chart

Design Pressure P.S.F.	Intermediate Vertical Mullion	Wall Jamb Mullion	Maximum Mullion Span	Maximum Mullion Spacing CL to CL	Maximum Glass Size		Qualified Glass Types
					D.L.O. W x H	Sq. Ft.	
+55/-55 Large Missile	FL574T/FL575T Heavy Duty Mullion	FL571T	120"	48"	45½" x 84"	27.19	IB, ID
+55/-55 Large Missile	FL574T/FL575T Heavy Duty Mullion	FL571T	120"	48"	45½" x 96"	30.3	ID
+60/-60 Small Missile	FL574T/FL575T Heavy Duty Mullion	FL571T	108"	48"	45½" x 103"	32.5	ID

Hurricane Impact-Resistant Products Disclaimer Note

Coral's hurricane impact-resistant products meet a variety of test standards for applications in coastal construction regions satisfying the demands for wind-borne debris hazards and high-velocity winds associated with hurricanes. All of Coral's hurricane impact-resistant products are independent laboratory tested based on a variety of test standards for air infiltration, water resistance, structural loads, missile impact and air-pressure cycling based ASTM and/or Florida Building Code. The informational chart above is intended to provide recommended limits in frame heights, glass sizes and design pressures based on product testing. When exceeding conditions listed above it is recommended to consult with licensed structural engineer or contact Coral Architectural Products.

Qualified Glass Types

Glass Type	Glass Composition			Interlayer Manufacturer	Glass Identification
	Exterior Lite	Air Space/Spacer Type	Interior Lite (Laminated Glass)		
1⅝" Insulated Glass	¼" Heat Strengthened or Tempered Glass	½" Air Space with Aluminum Box Spacer	¼" Heat Strengthened Glass .090 DVB ¼" HeatStrengthened Glass (Wet Glazed)	Kuraray	IB
1⅝" Insulated Glass	¼" Heat Strengthened or Tempered Glass	½" Air Space with Aluminum Box Spacer	¼" Heat Strengthened Glass .090 Sentry Glass Interlayer ¼" HeatStrengthened Glass (Dry Glazed)	Kuraray	ID
1⅝" Insulated Glass	¼" Heat Strengthened or Tempered Glass	½" Air Space with Aluminum Box Spacer	¼" Heat Strengthened Glass .035 Sentry Glass Interlayer ¼" HeatStrengthened Glass (Small Missile Application Only)	Kuraray	IC







Comparative Analysis of Glass Based on ASTM E-1300

Florida Product Control Office allows comparative analysis of tested glass types provided the following five conditions are met:

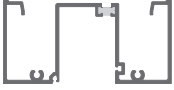
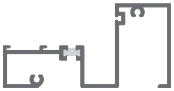

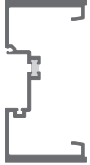









1. Does not exceed maximum cyclic pressure tested.
2. Does not exceed maximum span of mullion tested.
3. Does not exceed maximum mullion spacing of mullion tested.
4. Does not exceed maximum square footage of largest lite tested.
5. Does not exceed aspect ratio of 5:1 (in a rectangular configuration, the ratio of the long-side to the short-side is defined as the aspect ratio).

FL550T·2½" x 5"

Thermal Impact-Resistant Storefront

STANDARD FRAMING EXTRUSIONS									
PART DESCRIPTION	PART NO.	PART LENGTH	PCS. PER BOX	FINISH CODE/STOCK LENGTH LIST PRICE					
				#10 CLEAR	#20 BRONZE	#83 WHITE	#2604 POWDER	#2605 POWDER	
 Head/Wall Jamb (Deep Pocket)	FL571T	24'-3"	4	\$314	\$336	\$336	\$350	\$378	
 Sill/Optional Head (Deep Pocket)	FL572T	24'-3"	4	\$282	\$301	\$301	\$297	\$318	
 Glass Stop	FL553	24'-3"	10	\$70	\$76	\$76	\$109	\$124	
 Intermediate Horizontal	FL576T	24'-3"	4	\$302	\$314	\$314	\$374	\$403	
 Heavy Wall Vertical Mullion & Door-frame Jamb	FL574T	24'-3"	4	\$316	\$333	\$333	\$372	\$401	
 Pocket Filler (For use with FL574T)	FL575T	24'-3"	5	\$165	\$177	\$177	\$184	\$199	
 High Performance Subsill	FL539T	24'-3"	10	\$220	\$231	\$231	\$300	\$329	
 Transom Sash	FL567	24'-3"	10	\$65	\$71	\$71	\$103	\$118	
 Transom Glass Stop	FL518	24'-3"	10	\$35	\$38	\$38	\$82	\$98	

Note: Add Finish Code to the Part Number when ordering (Ex: **FL571T-10** for Clear Anodized Finish)

ACCESSORIES				ACCESSORIES			
PART DESCRIPTION	PART NO.	PART LENGTH	PRICE PER BOX	PART DESCRIPTION	PART NO.	PART LENGTH	PRICE PER BOX
 Spline Screw #14 x 1 HHSTS (Assembly Screw)	AS16	100 (AS16-1)	\$12	 4" Long EPDM Setting Block for 1¾" Glass (Two Per Lite at inverted horizontal)	SB15	100 (SB15-1)	\$148
 #6 x ¾" PPH Type AB (Attaches End Dams)	AS21	100 (AS21-1)	\$5	 SB17-1 Setting Block for Intermediate Horizontal FL550T Dry Glazed Inside Glaze	SB17	100 (SB17-1)	\$119
 Setting Chair (Two Per Lite Required at Sill Member)	CS500-1	50 (CS500-2)	\$90	 SB25-1 Setting Block Chair for Sill (FL571T) FL550T Dry Glazed Inside Glaze	SB25	25 (SB25-1)	\$61
 End Dam for Sill Flashing	ED519-1	20 (ED519-2)	\$33	 Water Diverter (Horizontal -Two Per Lite)	WD300-1	50 (WD300-2)	\$62
 Exterior EPDM Gasket	NG1	300 FT. (Per Roll)	\$135	 Joint Sealant Tape (¾" x ½" for Sealing Horizontal to Vertical Member Connections)	SM5601	30 FT. (Per Roll)	\$37
 EPDM Gasket for DS550 Door stop at Doorjamb	NG5	500 FT. (Per Roll)	\$275				
 ¾" Interior Spacer Gasket	NG14	500 FT. (Per Roll)	\$229				
 Dry Glazed Gasket	NG15	500 FT. (Per Roll)	\$332				

FL550T·2½" x 5"

Thermal Impact-Resistant Storefront



GLAZING INFILL CHART					
SYSTEM	REGLET WIDTH	GLAZING TECHNIQUE	INFILL THICKNESS	GASKET COMBINATIONS	
FL550	1⅝"	Wet Glazed	1⅝"	NG14 (DOW995)	NG1
		Dry Glazed	1⅝"	NG15	NG1

SETTING BLOCK AND SETTING CHAIR CHART					
GLASS SIZE	PART DESCRIPTION	PART NO.	GLAZING APPLICATION	SETTING BLOCK PART NO.	SETTING CHAIR PART NO.
1⅝"	Sill Member	FL552	Exterior Glazed	SB15	CS500-1
1⅝"	Intermediate Horizontal	FL556	Exterior Glazed	SB15	Not Required
		FL556	Interior Glazed	SB16	Not Required

Section F
IMPACT-RESISTANT CURTAIN WALLS
Table of Contents

PW256 Impact-Resistant Curtain Wall..... F1
PW257 Impact-Resistant Curtain Wall..... F2

Page Left Intentionally Blank

Section F1
 Table of Contents











2½" x 6⁹/₁₆"

for 9/16" Laminated Glass

	<i>Page</i>
Standard Framing Extrusions.....	1
Corner Framing Extrusions	2
Optional Framing Extrusions	3
Door Framing Extrusions	3
Accessories.....	4
Steel Reinforcing.....	5
Glazing Infill Charts and Setting Block/Setting Chair Charts	5

Page Left Intentionally Blank







STANDARD FRAMING EXTRUSIONS								
PART DESCRIPTION	PART NO.	PART LENGTH	PCS. PER BOX	FINISH CODE/STOCK LENGTH LIST PRICE				
				#10 CLEAR	#20 BRONZE	#81 WHITE	#2604 POWDER	#2605 POWDER
 9/16" Glazing Vertical Jamb Mullion	PW550	24'	3	\$253	\$270	\$270	\$287	\$313
 Butt Glaze Vertical Mullion	PW151	24'	3	\$219	\$234	\$234	\$259	\$285
 9/16" Glazing Head / Sill	PW552	24'	3	Mill-00	N/A	N/A	N/A	N/A
				\$185				
 9/16" Glazing Intermediate Horizontal	PW555	24'	3	\$246	\$263	\$263	\$253	\$272
 Vertical Mullion Filler	PW202	24'	12	\$91	\$98	\$98	\$125	\$143
 Head / Horizontal / Sill Trim	PW203	24'	4	\$133	\$144	\$144	\$180	\$205
 Pre-punched Pressure Bar w / spacer gasket	PW204-1	24'	12	Mill-00	N/A	N/A	N/A	N/A
				\$77				
 Vertical/Horizontal Face Cover	PW205	24'	12	\$42	\$47	\$47	\$78	\$92
 ¼" Transition Glazing Adapter for Butt - Glazed Mullion	PW513	24'	12	\$34	\$39	\$39	\$82	\$97

Note: Add Finish Code to the Part Number when ordering (Ex: **PW550-10** for Clear Anodized Finish)





PW256·2½" x 6⁹/₁₆"

Screw-Spline Curtain Wall



CORNER FRAMING EXTRUSIONS									
PART DESCRIPTION	PART NO.	PART LENGTH	PCS. PER BOX	FINISH CODE/STOCK LENGTH LIST PRICE					
				#10 CLEAR	#20 BRONZE	#81 WHITE	#2604 POWDER	#2605 POWDER	
 9/16" Glazing Tee 90° O.S. Corner	PW556	24'	4	Mill-00	N/A	N/A	N/A	N/A	
				\$100					
 90° O.S. Corner Prepunched Pressure Bar W/Spacer Gasket	PW154	24'	4	Mill-00	N/A	N/A	N/A	N/A	
				\$155					
 1" Glazing face cover 90° O.S. Corner (2 REQ'D)	PW158	24'	12	\$60	\$66	\$66	\$108	\$125	
 Female Half 90° O.S. Corner	PW208	24'	4	\$167	\$179	\$179	\$213	\$236	
 Male Half 90° O.S. Corner	PW209	24'	4	\$177	\$189	\$189	\$220	\$243	
 Interior 90° Corner Trim	PW210	24'	4	\$88	\$95	\$95	\$140	\$161	
 90° Corner Splice	PW211	24'	4	Mill-00	N/A	N/A	N/A	N/A	
				\$118					

Note: Add Finish Code to the Part Number when ordering (Ex: **PW550-10** for Clear Anodized Finish)

DOOR FRAMING EXTRUSIONS								
PART DESCRIPTION	PART NO.	PART LENGTH	PCS. PER BOX	FINISH CODE/STOCK LENGTH LIST PRICE				
				#10 CLEAR	#20 BRONZE	#81 WHITE	#2604 POWDER	#2605 POWDER
 Header / Transom Bar for Surface Mount Closer	FL207	24'	4	\$227	\$238	\$238	\$328	\$363
 Frame Jamb	PW214	24'	4	\$137	\$149	\$149	\$185	\$208
 COC Transom Bar / Header	FL212	24'	4	\$177	\$184	\$184	\$309	\$349
 Snap-in Door Stop (Use with FL207)	DS200	24'	3	\$31	\$34	\$34	\$72	\$86
 Screw Applied Door Stop (Use with FL212)	DS202	24'	4	\$78	\$84	\$84	\$137	\$157





OPTIONAL FRAMING EXTRUSIONS								
PART DESCRIPTION	PART NO.	PART LENGTH	PCS. PER BOX	FINISH CODE/STOCK LENGTH LIST PRICE				
				#10 CLEAR	#20 BRONZE	#81 WHITE	#2604 POWDER	#2605 POWDER
 Splice Sleeve / or Mullion Reinforcement	PW207	24'	3	Mill-00	N/A	N/A	N/A	N/A
				\$189				



Note: Add Finish Code to the Part Number when ordering (Ex: **PW550-10** for Clear Anodized Finish)

PW256·2½" x 6⅞"

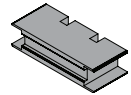
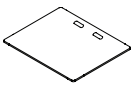
Screw-Spline Curtain Wall

ACCESSORIES			
PART DESCRIPTION	PART NO.	QTY	PRICE PER BOX
 Spline Screw #14 x 1 HHSTS	AS16	100 (AS16-1)	\$12
 Pressure Bar Screws	AS19	200 (AS16-1)	\$21
 #8 x 1/2" PPH B P+C	AS2	100 (AS2-1)	\$13
 #12 x ¾" HWH #3 Zinc Plated Self Drilling	AS25	100 (AS25-1)	\$8
 #14 x 1" FHP Self Drilling	AS35	100 (AS35-1)	\$14
 3 x 1/4 x 20 Hex Head Bolt SS	AS53	25 (AS53-1)	\$21
 1/4 Flat Washer SS	AS54	50 (AS54-1)	\$8
 1/4 x 20 Lock Nut SS	AS55	25 (AS55-1)	\$9
 Interior / Exterior Glazing Gasket at Glass	NG10	250 FT. (Per Roll)	\$129
 Exterior Perimeter Gasket	NG11	500 FT. (Per Roll)	\$261
 Butt Glaze Spacer Gasket	NG14	500 FT. (Per Roll)	\$204

ACCESSORIES			
PART DESCRIPTION	PART NO.	QTY	PRICE PER BOX
 Dry Glaze Gasket	NG16	500 FT.	\$557
 4" Long EPDM Setting Block for 1" Glass	SB14	100 (SB14-1)	\$79
 End Dam	SP202	50 (SP202-1)	\$57
 Butt Glaze Mullion Bridge for 1" Glazing	SP206	50 (SP206-1)	\$62
 Top and Bottom Mullion Cover	SP210	50	\$62
 Temporary Glazing Retainer	SP253	50 (SP253-1)	\$52
 Joint Sealant Tape (½" x ½" for Sealing Horizontal to Vertical Member Connections)	SM5601	30 FT. (Per Roll)	\$37

STEEL REINFORCING			
PART DESCRIPTION	PART NO.	QTY	PRICE
 1⅞" x 4½" x ¼" with Zinc Chromate Primer Steel Reinforcing	SR150	1	\$329
		12'-0"	
 1⅞" x 4½" x 10 Ga. Steel Reinforcing	SR151	1	\$296
		14'-0"	
 1⅞" x 4⅝" x ¼" with Zinc Chromate Primer Steel Reinforcing	SR504	1	\$292
		10'-0"	

Page Left Intentionally Blank

Section F2
 Table of Contents







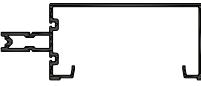

PW257 
Hurricane Impact-Resistant Curtain Wall

2½" x 7⁵/₁₆"

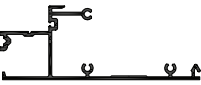
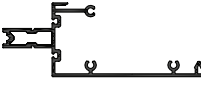
for 1⁵/₁₆" Laminated / Insulated Glass

	<i>Page</i>
Standard Framing Extrusions.....	1
Corner Framing Extrusions	2
Optional Framing Extrusions	3
Door Framing Extrusions	3
Accessories.....	4
Steel Reinforcing.....	5
Glazing Infill Charts and Setting Block/Setting Chair Charts	5







Page Left Intentionally Blank

STANDARD FRAMING EXTRUSIONS									
PART DESCRIPTION	PART NO.	PART LENGTH	PCS. PER BOX	FINISH CODE/STOCK LENGTH LIST PRICE					
				#10 CLEAR	#20 BRONZE	#81 WHITE	#2604 POWDER	#2605 POWDER	
 1-5/16" Glazing Vertical Jamb Mullion	PW650	24'	3	\$286	\$305	\$305	\$365	\$410	
 Butt Glaze Vertical Mullion	PW151	24'	3	\$219	\$234	\$234	\$259	\$285	
 1-5/16" Glazing Head Sill	PW652	24'	3	Mill-00	N/A	N/A	N/A	N/A	
				\$217					
 1-5/16" Glazing Intermediate Horizontal	PW655	24'	3	\$280	\$297	\$297	\$333	\$368	
 Vertical Mullion Filler	PW202	24'	12	\$91	\$98	\$98	\$125	\$143	
 Head / Horizontal / Sill Trim	PW203	24'	4	\$133	\$144	\$144	\$180	\$205	
 Pre-punched Pressure Bar w / spacer gasket	PW204-1	24'	12	Mill-00	N/A	N/A	N/A	N/A	
				\$77					
 Vertical/Horizontal Face Cover	PW205	24'	12	\$42	\$47	\$47	\$78	\$92	
 ¼" Transition Glazing Adapter for Butt - Glazed Mullion	PW613	24'	12	\$48	\$51	\$51	\$85	\$100	

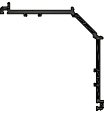



Note: Add Finish Code to the Part Number when ordering (Ex: **PW650-10** for Clear Anodized Finish)

PW257·2½" x 7⁵/₁₆"

Screw-Spline Curtain Wall

CORNER FRAMING EXTRUSIONS									
PART DESCRIPTION	PART NO.	PART LENGTH	PCS. PER BOX	FINISH CODE/STOCK LENGTH LIST PRICE					
				#10 CLEAR	#20 BRONZE	#81 WHITE	#2604 POWDER	#2605 POWDER	
 1-5/16" Glazing Tee 90° O.S. Corner	PW656	24'	4	Mill-00	N/A	N/A	N/A	N/A	
				\$123					
 90° O.S. Corner Prepunched Pressure Bar W/Spacer Gasket	PW654	24'	4	Mill-00	N/A	N/A	N/A	N/A	
				\$125					
 1-5/16" Glazing face cover 90° O.S. Corner (2 REQ'D)	PW658	24'	12	\$64	\$70	\$70	\$113	\$132	
 Female Half 90° O.S. Corner	PW208	24'	4	\$167	\$179	\$179	\$213	\$236	
 Male Half 90° O.S. Corner	PW209	24'	4	\$177	\$189	\$189	\$220	\$243	
 Interior 90° Corner Trim	PW210	24'	4	\$88	\$95	\$95	\$140	\$161	
 90° Corner Splice	PW211	24'	4	Mill-00	N/A	N/A	N/A	N/A	
				\$118					

Note: Add Finish Code to the Part Number when ordering (Ex: **PW650-10** for Clear Anodized Finish)



DOOR FRAMING EXTRUSIONS								
PART DESCRIPTION	PART NO.	PART LENGTH	PCS. PER BOX	FINISH CODE/STOCK LENGTH LIST PRICE				
				#10 CLEAR	#20 BRONZE	#81 WHITE	#2604 POWDER	#2605 POWDER
 Header / Transom Bar for Surface Mount Closer	FL207	24'	4	\$227	\$238	\$238	\$328	\$363
 Frame Jamb	PW214	24'	4	\$137	\$149	\$149	\$185	\$208
 COC Transom Bar / Header	FL212	24'	4	\$177	\$184	\$184	\$309	\$349
 Snap-in Door Stop (Use with FL207)	DS200	24'	3	\$31	\$34	\$34	\$72	\$86
 Screw Applied Door Stop (Use with FL212)	DS202	24'	4	\$78	\$84	\$84	\$137	\$157







OPTIONAL FRAMING EXTRUSIONS								
PART DESCRIPTION	PART NO.	PART LENGTH	PCS. PER BOX	FINISH CODE/STOCK LENGTH LIST PRICE				
				#10 CLEAR	#20 BRONZE	#81 WHITE	#2604 POWDER	#2605 POWDER
 Splice Sleeve / or Mullion Reinforcement	PW207	24'	3	Mill-00	N/A	N/A	N/A	N/A
				\$189				

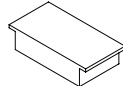

Note: Add Finish Code to the Part Number when ordering (Ex: **PW650-10** for Clear Anodized Finish)

PW257·2½" x 7⁵/₁₆"

Screw-Spline Curtain Wall

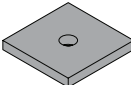
ACCESSORIES			
PART DESCRIPTION	PART NO.	QTY	PRICE PER BOX
 Spline Screw #14 x 1 HHSTS	AS16	100 (AS16-1)	\$12
 #8 x 1/2" PPH	AS2	100 (AS2-1)	\$12
 #12 x ¾" HWH #3 Zinc Plated Self Drilling	AS25	100 (AS25-1)	\$8
 12 x 1¼" HWH #3 Zinc Plated Self Drilling <small>(Pressure Bar Screws)</small>	AS32	200 (AS32-1)	\$18
 #14 x 1" FHP Self Drilling	AS35	100 (AS35-1)	\$14
 3 x 1/4 x 20 Hex Head Bolt SS	AS53	25 (AS53-1)	\$21
 1/4 Flat Washer SS	AS54	50 (AS54-1)	\$8
 1/4 x 20 Lock Nut SS	AS55	25 (AS55-1)	\$9
 Interior / Exterior Glazing Gasket at Glass	NG10	250 FT. (Per Roll)	\$129
 Exterior Perimeter Gasket	NG11	500 FT. (Per Roll)	\$261
 Butt Glaze Spacer Gasket	NG14	500 FT. (Per Roll)	\$204.00

ACCESSORIES			
PART DESCRIPTION	PART NO.	QTY	PRICE PER BOX
 Dry Glaze Gasket	NG16	500 FT.	\$557
 4" Long EPDM Setting Block for 1" Glass	SB18	100 (SB18-1)	\$67
 End Dam	SP204	50 (SP204-1)	\$20
 Butt Glaze Mullion Bridge for 1" Glazing	SP208	50 (SP208-1)	\$49
 Top and Bottom Mullion Cover	SP211	50 (SP211-1)	\$62
 Temporary Glazing Retainer	SP253	50 (SP253-1)	\$52
 Joint Sealant Tape <small>(1/8" x 1/2" for Sealing Horizontal to Vertical Member Connections)</small>	SM5601	30 FT. (Per Roll)	\$37
 1.475 x 1.475 x .180 Zinc Plated Steel Square Nut	AS13	50	\$44

STEEL REINFORCING			
PART DESCRIPTION	PART NO.	QTY	PRICE
 1⅞" x 4½" x ¼" with Zinc Chromate Primer Steel Reinforcing	SR150	1	\$329
		12'-0"	
 1⅞" x 4½" x 10 Ga. Steel Reinforcing	SR151	1	\$296
		14'-0"	
 1⅞" x 4⅝" x ¼" with Zinc Chromate Primer Steel Reinforcing	SR504	1	\$292
		10'-0"	